



KA8585

4K Quad Display KVM over IP
Console Station

User Manual

Compliance Statements

FEDERAL COMMUNICATIONS COMMISSION INTERFERENCE STATEMENT

This equipment has been tested and found to comply with the limits for a Class A digital device, pursuant to Part 15 of the FCC Rules. These limits are designed to provide reasonable protection against harmful interference when the equipment is operated in a commercial environment. This equipment generates, uses, and can radiate radio frequency energy and, if not installed and used in accordance with the instruction manual, may cause harmful interference to radio communications. Operation of this equipment in a residential area is likely to cause harmful interference in which case the user will be required to correct the interference at his own expense.

The device complies with Part 15 of the FCC Rules. Operation is subject to the following two conditions: (1) this device may not cause harmful interference, and (2) this device must accept any interference received, including interference that may cause undesired operation.

FCC Caution

Any changes or modifications not expressly approved by the party responsible for compliance could void the user's authority to operate this equipment.

Warning

Operation of this equipment in a residential environment could cause radio interference.

Achtung

Der Gebrauch dieses Geräts in Wohnumgebung kann Funkstörungen verursachen.



KCC Statement:

유선 제품용 / A 급 기기 (업무용 방송 통신 기기)
 이 기기는 업무용 (A 급) 전자파적합기기로서 판매자 또는 사용자는 이
 점을 주의하시기 바라며, 가정 외의 지역에서 사용하는 것을 목적으로
 합니다.

HDMI Trademark Statement

The terms HDMI, HDMI High-Definition Multimedia Interface, HDMI trade dress and the HDMI Logos are trademarks or registered trademarks of HDMI Licensing Administrator, Inc.



RoHS

This product is RoHS compliant.

User Information

Online Registration

Be sure to register your product at our online support center:

International	http://eservice.aten.com
---------------	---

Telephone Support

For telephone support, call this number:

International	886-2-8692-6959
China	86-400-810-0-810
Japan	81-3-5615-5811
Korea	82-2-467-6789
North America	1-888-999-ATEN ext 4988 1-949-428-1111

User Notice

All information, documentation, and specifications contained in this manual are subject to change without prior notification by the manufacturer. The manufacturer makes no representations or warranties, either expressed or implied, with respect to the contents hereof and specifically disclaims any warranties as to merchantability or fitness for any particular purpose. Any of the manufacturer's software described in this manual is sold or licensed as *is*. Should the programs prove defective following their purchase, the buyer (and not the manufacturer, its distributor, or its dealer), assumes the entire cost of all necessary servicing, repair and any incidental or consequential damages resulting from any defect in the software.

The manufacturer of this system is not responsible for any radio and/or TV interference caused by unauthorized modifications to this device. It is the responsibility of the user to correct such interference.

The manufacturer is not responsible for any damage incurred in the operation of this system if the correct operational voltage setting was not selected prior to operation. PLEASE VERIFY THAT THE VOLTAGE SETTING IS CORRECT BEFORE USE.

Product Information

For information about all ATEN products and how they can help you connect without limits, visit ATEN on the Web or contact an ATEN Authorized Reseller. Visit ATEN on the Web for a list of locations and telephone numbers:

International	http://www.aten.com
North America	http://www.aten-usa.com

Package Contents

Check to make sure that all the components are in working order. If you encounter any problem, please contact your dealer.

- 1 KA8585 4K Quad Display KVM over IP Console Station
- 1 power adapter
- 1 user instructions

About This Manual

This manual is intended to help you maximize the capabilities of your KA8585 KVM over IP Console Station. It provides comprehensive guidance on installation, configuration, and operation.

Note:

- ◆ Read this manual thoroughly and follow the installation and operation procedures carefully to prevent any damage to the unit or connected devices.
 - ◆ The product may be updated, with features and functions added, improved, or removed since the release of this manual. For an up-to-date user manual, visit <http://www.aten.com/global/en/>
-

Conventions

This manual uses the following conventions:

- | | |
|---|--|
| Monospaced | Indicates text that you should key in. |
| [] | Indicates keys you should press. For example, [Enter] means to press the Enter key. If keys need to be chorded, they appear together in the same bracket with a plus sign between them: [Ctrl+Alt]. |
| 1. | Numbered lists represent procedures with sequential steps. |
| ◆ | Bullet lists provide information, but do not involve sequential steps. |
| > | Indicates selecting consecutive options (such as on a menu or dialog box). For example, Start > Run means to open the <i>Start</i> menu, and then select <i>Run</i> . |
|  | Indicates critical information. |

Contents

Compliance Statements	ii
User Information	iv
Online Registration	iv
Telephone Support	iv
User Notice	iv
Product Information	v
Package Contents	v
About This Manual	v
Conventions	vi
Contents	1

Chapter 1. Introduction

Overview	1
Features	1
Requirements and Considerations	3
Setup Consideration	3
Compatible Products	3

Chapter 2. Hardware Setup

Overview	4
Before You Begin	4
Hardware Overview	5
Installation	6
Rack Mount	7
Powering Off the Console Station	7

Chapter 3. Management Console

Overview	8
Accessing the Management Console	8
Main Screen	9
Control Mode	10
Array Monitoring	12
Array Monitoring Toolbar	13
Configuring an Individual Input in Array Monitoring	14
Configuring an Individual Input	15
Accessing the Toolbar	15
Toolbar	16
Layout Configuration	19
Adding a New Layout	19
Opening a Previously Created Layout	20
Renaming a Layout	21
Deleting One or More Layouts	22

Closing Layouts	23
---------------------------	----

Chapter 4. Device Management

Overview	24
Adding a Device	24
Updating Device Credentials	26
Deleting a Device	27

Chapter 5. System Configuration

Overview	28
Account Management	28
User Accounts	28
Adding a User Account	28
Modifying a User Account	30
Duplicating a User Account	31
Deleting a User Account	31
Group Accounts	31
Adding a Group Account	31
Account Policy	34
System Management	35
Checking General System Settings	35
Network Settings	36
ANMS	38
Security	40
Date & Time	41
Maintenance	43
Upgrading the System Firmware	43
Configuration Backup	43
Restoring System Configuration with a Previous Backup	44
Terminal	45
Supported Commands	45
Configuring the Monitor Arrangement	47
Resetting the System to Default Settings	48
System Maintenance	49
Changing the Password	49
Rebooting the Console Station	49
User Preferences	49
Interface Language	50
Auto Logout	50
Array Monitoring Settings	50
Control Mode Settings	53

Appendix

Safety Instructions	56
-------------------------------	----

General	56
Rack Mounting	57
Technical Support	59
International	59
North America	59
Specifications	60
Troubleshooting	62
General Operation	62
Mouse Usage	63
ATEN Warranty Policy	64

Chapter 1

Introduction

Overview

The ATEN KA8585 4K Quad-Display KVM over IP Console Station is a Linux-based station that enables centralized, real-time remote control and monitoring of servers and/or PCs connected to multiple KVM over IP switches, such as ATEN's CN9 series and KG series, over an IP network. The console station supports installation with up to four displays, providing visual workspace for efficient control and monitoring operations.

The console station offers two operating modes — Control Mode and Array Monitoring mode — to support a wide range of control and monitoring needs. In Control Mode, users can monitor and operate managed devices using the console keyboard and mouse; in Array Monitoring mode, users can monitor up to 64 sources simultaneously. The console station also provides access to the web GUI of the managed devices. Layouts for both modes are highly customizable to accommodate different infrastructure requirements and usage scenarios.

Features

- ◆ A high-performance, all-digital standalone console that replaces a PC or laptop
- ◆ Delivers crystal-clear 4K video from KG / CN series all-digital KVM over IP switches without smearing or color bleeding, enabling users to remotely access, monitor, and control all servers connected to KVM over IP switches
- ◆ Provides impenetrable security against virus threats and robust data protection
- ◆ Supports single sign-on to consolidate the management of multiple KG / CN series KVM over IP switches

- ◆ Panel Array Mode™ Live+ — real-time monitoring of live-streamed video feeds from all ports in a configurable multi-screen layout, scalable as needed (up to 8 x 8 per screen)
- ◆ Features both a Control Mode and an Array Monitoring mode for each screen, giving users intuitive and flexible options to meet specific application requirements
- ◆ In Array Monitoring, the KA8585 supports Panel Array Mode™ Live+, enabling administrators to view up to 64 servers per screen — or up to 256 servers across four displays — in real time
- ◆ Each source appears as in a grid within the Control Mode layout, which can be resized and displayed in PoP or PbP mode, or automatically arranged by pressing the auto layout icon
- ◆ 2 HDMI and 2 DisplayPort video outputs — enable users to multi-task across four 4K displays using a single keyboard and mouse
- ◆ Supports Boundless Switching, allowing users to control up to 4 screens with one set of keyboard & mouse
- ◆ Extended desktop — supports extended display for remotely connected PCs on the four screens of KA8585
- ◆ Web-based GUI with multi-language support

Requirements and Considerations

Setup Consideration

- ◆ Make sure the network infrastructure provides a minimum bandwidth of 1Gbps.
- ◆ The usage of Control Mode requires sufficient CPU resources (from the console station) and network bandwidth. For optimal performance, ATEN recommends configuring Control Mode on one display and Array Monitoring mode on the remaining three displays.
- ◆ For the best operation experience, ATEN recommends using a 2 x 2 layout for Control Mode.

Compatible Products

The KA8585 console station is compatible with some of ATEN's KVM over IP switches. Visit the product page for a comprehensive list of compatible products and accessories.

Chapter 2

Hardware Setup

Overview

This chapter provides the precautions and detailed instructions on how to set up the Console Station.

Before You Begin



1. Important safety information regarding the placement and grounding of this device is provided on page 56 and onwards. Please review it before proceeding.
2. Make sure that power to all the devices you will be connecting up have been turned off. You must unplug the power cords of any computers that have the Keyboard Power On function.
3. Please operate the device with caution when under high environmental temperatures, as the surface of the device may become overheated under such conditions. For instance, the surface temperature of the device may reach 70 °C (158 °F) or higher when the environmental temperature reaches close 50 °C (122 °F).

Hardware Overview

Refer to the diagram and the table below for an overview of the console station's connection ports, LED indicators, and other controls on the device panels.

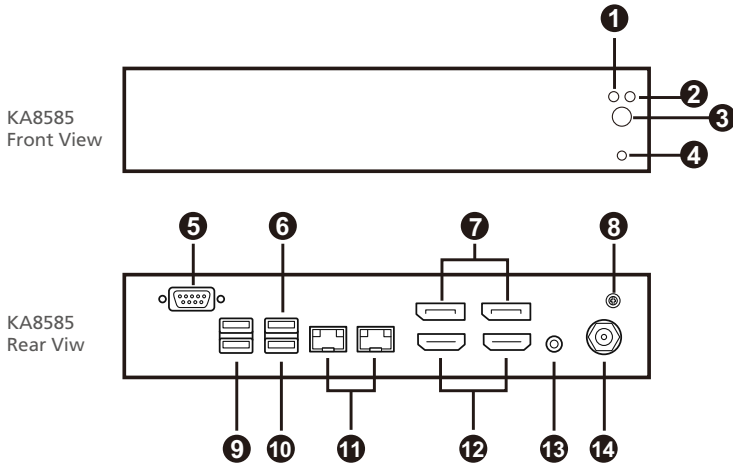

No.	Component	Description
1	SSD LED	The solid-state drive (SSD) LED flashes to indicate data transmission in progress.
2	power LED	Lights up to indicate that the console station is receiving power.
3	power button	<ul style="list-style-type: none"> ◆ Power on: Press the power button once. ◆ Power off: press and hold the power button for 4-5 seconds to turn off the console station.
4	reset button	Use a pin to press and hold the reset button for 3 seconds to reset the console station to factory defaults. This resets the device's system and network settings.
5	RS-232 serial port	<i>Reserved for future expansion.</i>
6	USB Type-A port	Connect to a keyboard.
7	DisplayPort out	Connect up to two DisplayPort-enabled monitors.
8	grounding terminal	Grounding terminal

No.	Component	Description
9	USB Type-A ports (storage)	Connect USB storages to the console station for firmware upgrades.
10	USB Type-A port (mouse)	Connect a USB mouse to the console station using this port.
11	RJ-45 ports (LAN 1 / LAN 2)	Provide network redundancy with two Ethernet ports.
12	HDMI out	Connect up to two HDMI-enabled monitors.
13	audio out	Connects to a speaker.
14	power jack	Receives power using the supplied power adapter.

Installation

Refer to the diagram and procedure below to install the console station.

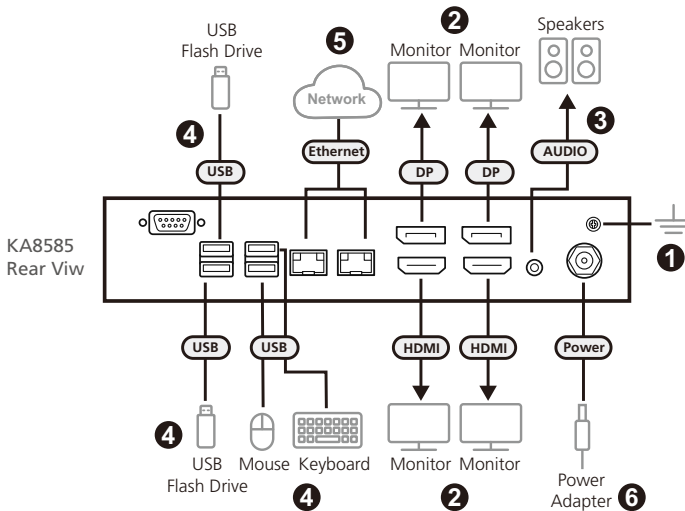

1. Use a grounding wire to ground the unit by connecting one end to the grounding terminal and the other end to a suitable grounded object.

Note: Do not omit this step. Proper grounding helps prevent damage to the unit from power surges or static electricity.

2. Connect the unit's DisplayPort and HDMI output ports to two DisplayPort and two HDMI monitors.
3. Connect the unit's audio output port to a set of speakers.
4. Connect the unit's USB Type-A ports to a USB keyboard, a USB mouse, and up to two USB flash drives.
5. The KA8585 is equipped with two RJ-45 ports. Connect the RJ-45 ports (LAN 1 / LAN 2) using Cat 5e/6/6a cables for network redundancy.
6. Connect the unit to power by plugging the power adapter provided in an AC power source and plugging its cable into the unit's DC power jack.
7. Press the power button to turn on the console station.

Rack Mount

The Console Station can be rack mounted on a 2-in-1U mounting plate (ATEN 2K-0008). For more information about this accessory, click [here](#) to visit the product page.

Powering Off the Console Station

If it becomes necessary to power off the console station, please press and hold the power button on the front panel for 4–5 seconds

Chapter 3

Management Console

Overview

The KVM over IP console station is a central control station used to monitor several KVM switches. Administrators can log in the management console and remotely monitor and control the PCs and/or servers connected to these KVM over IP devices.

Accessing the Management Console

To access the KA8585's management console, type in the username and password on the login page, and click **Login**. To clear the typed input, click **Reset**.



Note: Upon first login, enter the default credentials administrator and password. For security reasons, you will then be redirected to change the credentials before proceeding.

Main Screen

When logged in to the console station, the main screen appears as follows, showing the Control Mode tab. Refer to the following table for an overview of the controls and functions on the main screen.

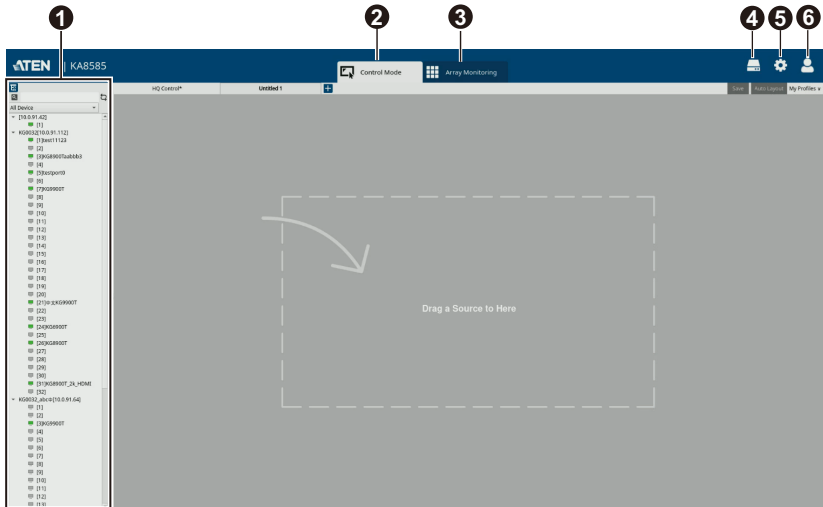

No.	Control	Description
1	Port List	Shows the servers or PCs installed to each port of the added devices and their online/offline status.
2	Control Mode	Opens the control mode panel for remote control and monitoring. For more details, see <i>Control Mode</i> , page 10.
3	Array Monitoring	Opens the array monitoring panel. For more details, see <i>Array Monitoring</i> , page 12.
4	Device Management	Opens the device management page with which you can add, remove, or modify added devices. For full information, see Chapter 4, <i>Device Management</i> .
5	System Configuration	For full information, see Chapter 5, <i>System Configuration</i> .

No.	Control	Description
6	Account Management	<p>Click this tab to access the following settings.</p> <ul style="list-style-type: none"> ◆ Change password: Sets the password of the currently logged-in account. ◆ User Preferences: Contains settings for the appearance of the console station's management console, such as the interface language and the appearance of the Array Monitoring and Control Mode screens. For details, see <i>User Preferences</i>, page 49. ◆ Logout: Logs out the console station's management console. ◆ Reboot: Reboots the console station. ◆ Shutdown: Shuts down the console station. ◆ About: Shows general device information including the device model, firmware version, and the IP addresses of the console station.

Control Mode

Use the Control Mode tab to remotely control up to 4 x 4 (16) sources on a single display with the console station's keyboard and mouse. Refer to the table below for an overview of the Control Mode tab.

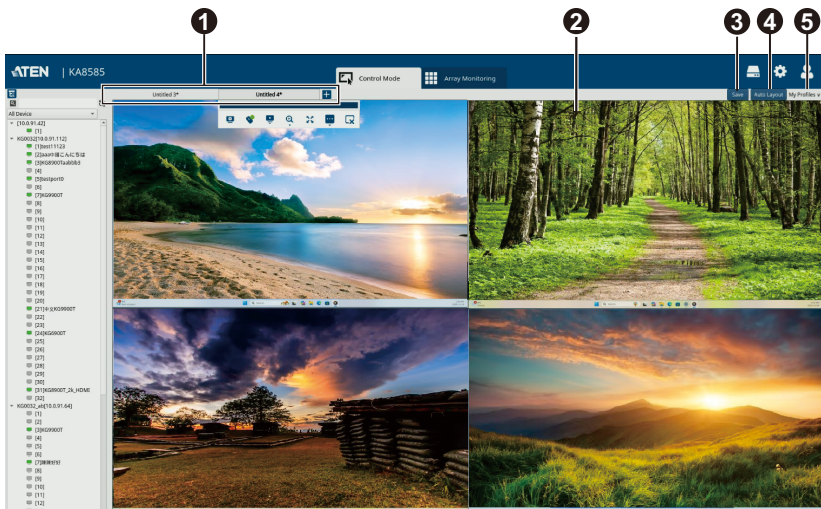

No.	Control	Description
1	Layout Tabs	All opened layouts appear here. Click any of these tabs to switch between them.
2	Preview Panel	Shows a preview of the displayed sources. This illustration shows a 2 x 2 panel, containing 4 grids.
3	Save	Click Save to store your currently viewing layout.
4	Auto Layout	Automatically removes blank inputs, re-arranged all displayed sources from left to right, top to bottom of the Control Mode panel, and adjusts each source to fit to the grid.
5	My Profiles (Layouts)	Click My Profiles to access created layouts or the Layout Management window (page 21).

Array Monitoring

Use the Array Monitoring tab to monitor up to 8 x 8 (64) sources on a single display in real-time.

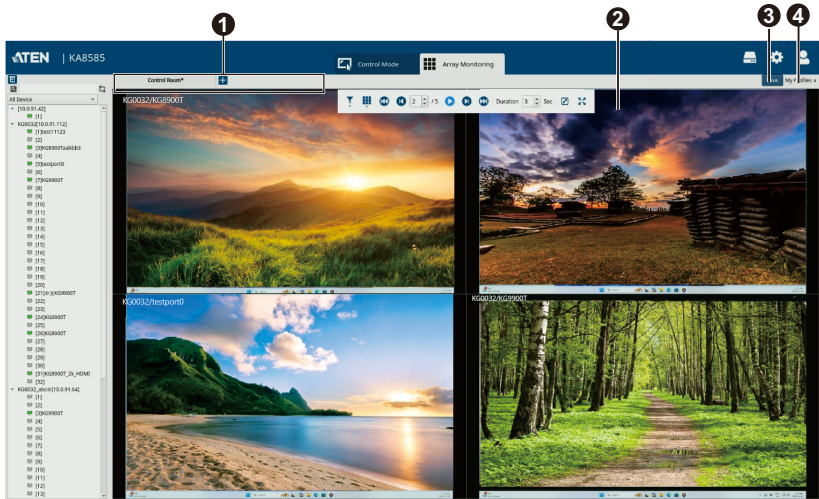

No.	Control	Description
1	Layout Tabs	All opened layouts appear here. Click any of these tabs to switch between them.
2	Preview Panel	Shows a preview of the displayed sources. The above illustration shows a 2 x 2 panel, containing 4 grids.
3	Save	Click Save to store your currently viewing layout.
4	My Profiles (Layouts)	Click My Profiles to access created layouts or the Layout Management window (page 21).

Array Monitoring Toolbar

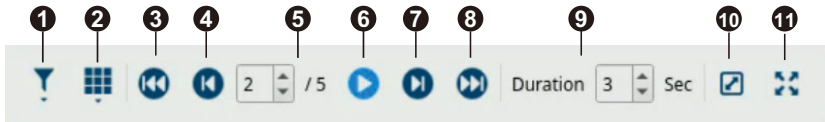

No.	Control	Description
1	Filter	Filters the displayed inputs. <ul style="list-style-type: none"> ◆ Online Only: Shows the online devices (ports) only ◆ Expand All / Collapse: Shows each added input (ports) in a single grid (Expand All) or collapse them. Click this option to toggle between these two settings.
2	Array Configuration	Sets the array configuration. <ul style="list-style-type: none"> ◆ Fit Canvas: Automatically selects an array configuration that fits the inputs, in their largest size possible, to the array monitoring preview area. ◆ Customize: Select this option to customize the array configuration.
3	Go to the First Page	Click to go to the first page of the array monitoring view.
4	Previous Page	Click the button to go to the previous page of the array monitoring view.
5	Current Page	Indicates the current page and the total number of pages for array monitoring.
6	Play / Pause	Click the button to play or pause the input streaming.
7	Next Page	Click the button to go to the next page of the array monitoring view.
8	Go to the Last Page	Click the button to go to the last page of the array monitoring view.
9	Refresh Interval	Defines the interval at which the array monitoring panels shows the next page.
10	Fit to Window / Keep Original Ratio	Click the button to toggle between <i>Fit to Window (grid)</i> and <i>Keep Original Ratio</i> mode.
11	Expand to Full Screen	Click the button to expand the array to full screen. This hides the port list and the toolbar.

Configuring an Individual Input in Array Monitoring

1. To configure an individual source, move the cursor to the top-right corner of the source. A **Menu** button appears.



2. Click **Menu** to access settings.

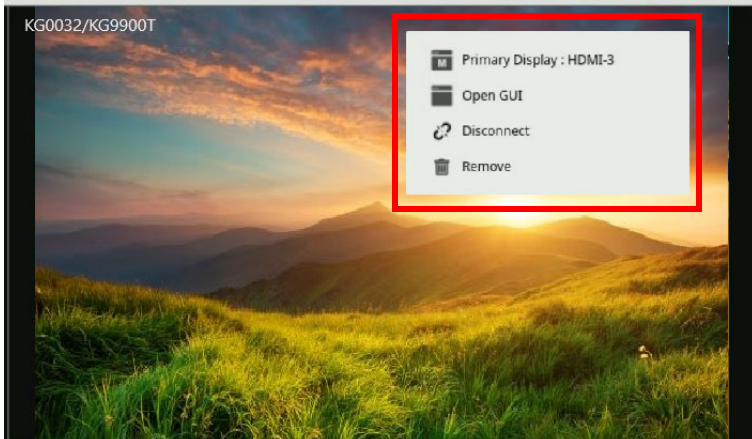

Control	Description
Primary Display: HDMI-3	Make this source a primary display shown on the monitor connected to port 3 (HDMI) of the console station. As soon as a source is made primary, the grid extends to full screen. To close the full screen and return to the array monitoring panel, click  from the array monitoring toolbar.
Open GUI	Opens the server or PC's web GUI.

Control	Description
Disconnect	Disconnects the source from the console station.
Remove	Removes this source from the grid.

Configuring an Individual Input

Use the toolbar to adjust the display settings of an individual input.

Accessing the Toolbar

1. Access the toolbar in one of the following methods
 - ◆ Click the **Array Monitoring** tab (*Proceed to step 2*)
 - ◆ Click the **Control Mode** tab (*Proceed to step 3*)
2. Double-click an input. The input extends to full screen.
3. Move the cursor to the top center of the grid. An arrow appears.

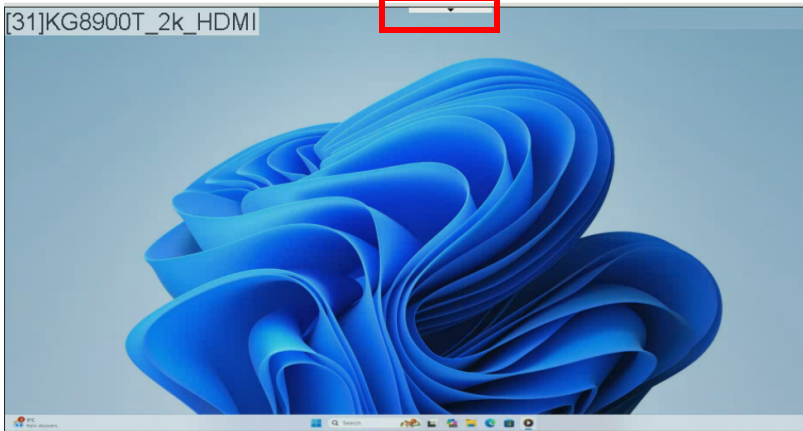

4. Move the cursor to the arrow. The toolbar appears.

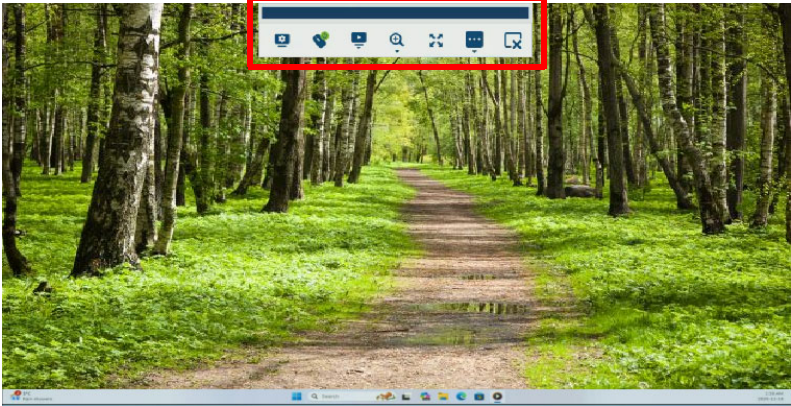





5. Click to access the toolbar functions. For full details of the toolbar, see *Toolbar*, page 16.

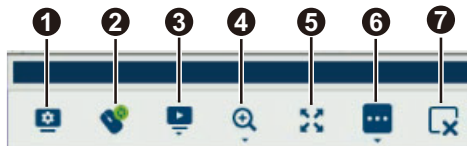

Toolbar

See the table below for details on the functions of toolbar controls.

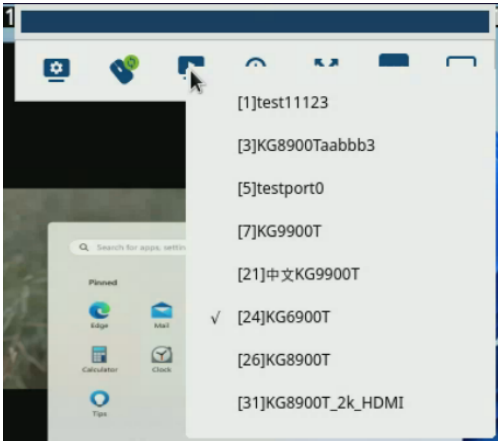

No.	Control	Description
1	 Video Settings	Provides the following controls: <ul style="list-style-type: none"> ◆ Video quality: Move the slider bar to adjust the video quality. ◆ Enhanced text mode: Enable this setting to enhance text display to improve visual clarity. ◆ Set to grayscale: Enable this setting to display content using only shades of gray instead of colors.

No.	Control	Description
2	 Mouse Sync Mode	<p>Sets how the local and remote mouse pointer is synchronized.</p> <ul style="list-style-type: none"> ◆ Automatic: Automatically synchronizes the remote and local mouse pointers. This is the default setting. ◆ For Mac 2: Select this option if automatic synchronization is not satisfactory and the remote server is Mac-based. ◆ For Red Hat AS 3.0: Select this option if automatic synchronization is not satisfactory, and the remote server is running Red Hat Enterprise Linux AS version 3). ◆ Manual: If the default synchronization is not satisfactory, and the For Mac 2 or For Red Hat AS 3.0 settings are not applicable for your target server, select this option.
3	 Connect	<p>Provides a quick access to switch to another input.</p> <ol style="list-style-type: none"> 1. Click the Connect button. 2. In a pop-up menu, select an input from a list of available inputs. For example: <div data-bbox="485 778 980 1220" style="border: 1px solid black; padding: 5px; margin: 10px 0;">  </div> 3. The selected input displays in the grid.
4	 Display Size	<p>Click the button to access the following settings:</p> <ul style="list-style-type: none"> ◆ Scale Window Size: Change the size of the grid. ◆ Fit to Window: Fits the input to the grid. ◆ Fit Canvas: Fit the input to the preview area.

No.	Control	Description
5	 Expand to Full Screen	Fits the input to the screen. Click again to return to the normal, grid display.
6	 Configuration	<p>Click the button to access the following settings:</p> <ul style="list-style-type: none"> ◆ Open GUI: Opens the server or PC's web GUI for remote configuration and management. ◆ Speaker: Mute or unmute the audio input. ◆ NumLock: Locks the number keys. ◆ CapsLock: Locks the Cap key. ◆ ScrLock: Locks the scroll key. ◆ Disconnect: Disconnect the input.
7	 Remove Input	<ul style="list-style-type: none"> ◆ In Control Mode: Click the button to remove the input from the grid. ◆ In Array Monitoring: Click the button to close the full screen and return to the array monitoring panel.

Layout Configuration

Adding a New Layout

1. Make sure you are in the Control Mode or Array Monitoring tab, depending on which layout you would like to create.
2. Click **+** and a menu appears.
 - ◆ Layout options for **Control Mode**

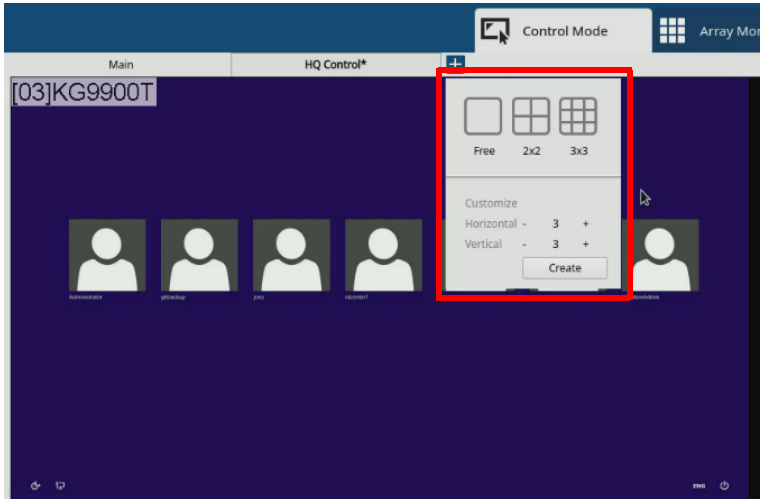

- ◆ Layout options for **array monitoring**

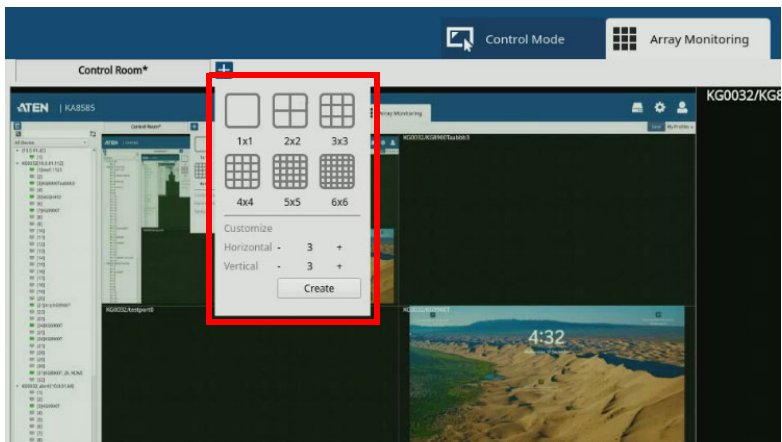

3. In the pop-up menu, select a layout grid or configure one from the Customize section and click **Create**. The selected/configured grid is added to the preview area.
4. Click **Create**. The layout appears in a separate tab.
5. To assign inputs to the displays, drag-and-drop sources from the Port List to the grid.
6. Click **Save** and name the profile in a pop-up dialog box.

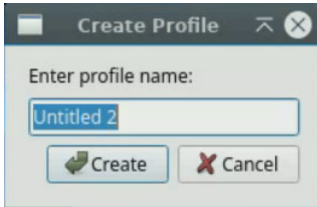

Opening a Previously Created Layout

1. From the console station's main screen, click the **Control Mode** tab or **Array Monitoring** tab.
2. Click **My Profiles**. A list of previously created layout appears.

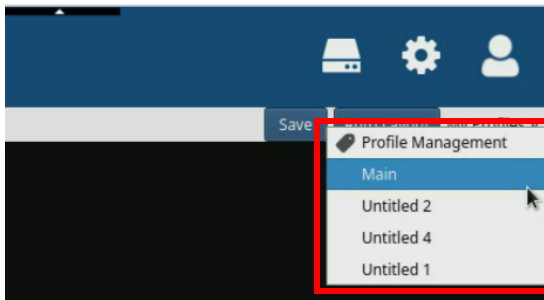

3. Click a layout to open it to the preview area.

Renaming a Layout

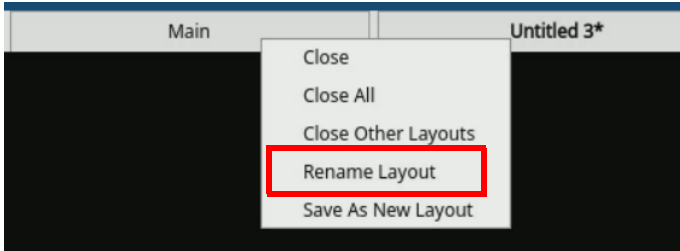

Use one of the following methods to rename layouts.

- ◆ Right-click on the layout tab and select **Rename Layout** from the pop-up menu.

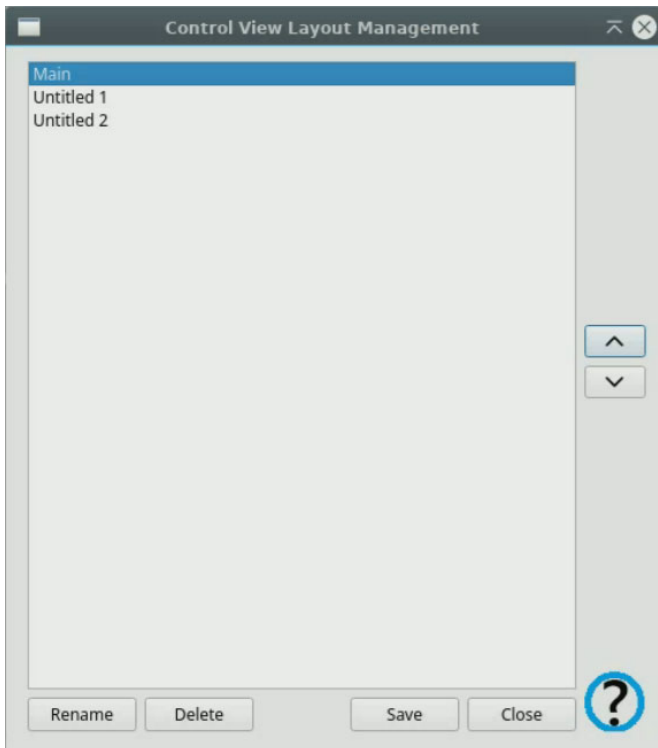

- ◆ From the console station's main screen, click the **My Profiles** button, and then select **Profile Management**. Select a profile and click **Rename**.



To adjust the order of a listed layout, click to select the layout, and then click the arrow buttons   to move it up or down the list.

Deleting One or More Layouts

1. From the console station's main screen, click the **Control Mode** tab or **Array Monitoring** tab.
2. Click **My Profiles**. This menu appears.

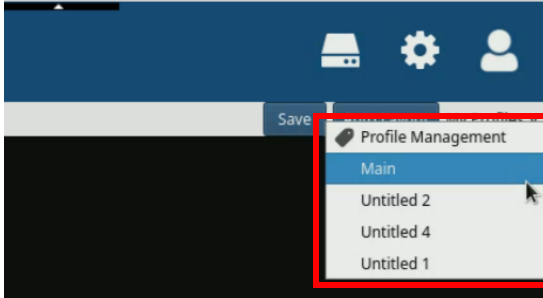

3. Select **Profile Management**. This window appears.

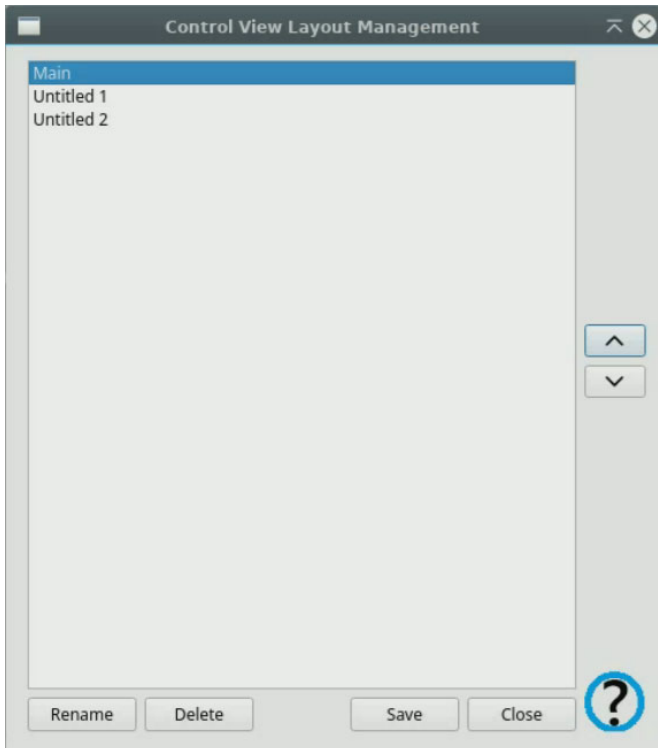

4. Select a layout and click **Delete** to remove the layout.

Closing Layouts

To close one or more layouts, right-click on the layout toolbar, and select one of the following depending on your needs.

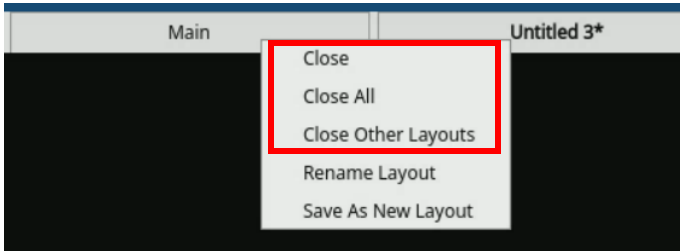

Option	Description
Close	Close the selected layout.
Close All	Close all opened layouts.
Close Other Layouts	Close all other layouts and keep the selected one open.

Chapter 4

Device Management

Overview

This chapter describes the procedures for adding remote servers to the KA8585 console station and maintaining the device list.

Adding a Device

1. From the console station's management console, click  **Device Management**. The device list appears.



The screenshot shows a web interface titled "Device Management" with a back arrow on the left. Below the title are three buttons: "Add", "Edit", and "Delete". A table displays a list of devices with columns for "Device Name", "Devices", and "IP Address".

	Device Name	Devices	IP Address
1		KVM	10.0.91.42
2	KG0032	KVM	10.0.91.112
3	KG0032_ab	KVM	10.0.91.64
4	RCM-CN9600	KVM	10.0.90.203

2. Click **Add**. This screen appears.

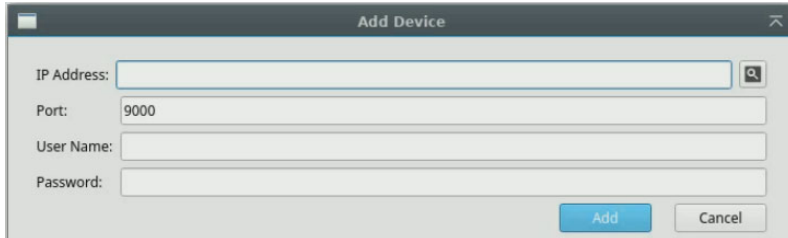

The screenshot shows a dialog box titled "Add Device" with a close button in the top right corner. It contains four input fields: "IP Address:" (with a search icon), "Port:" (with the value "9000"), "User Name:", and "Password:". At the bottom right are two buttons: "Add" and "Cancel".

3. In the Add Device screen, configure the following.
 - a) From the IP address field, click  to browse for available devices. Available devices appear in a table. Double-click a device to add it.



Device Name	IP Address	IPv6 Address
KG0016	10.0.91.20	
KG0032	10.0.91.112	2009:1:2:3::112
KG0016	10.0.91.80	2008:1:2:3::123
CN9600	10.0.91.22	2008:1:2:3::2025
ATEN CN9950-BX(1	10.0.91.42	fe80::210:74ff:feb0:fff
CN9000RCMQAtest	10.0.91.115	fe80::210:74ff:feb3:871a
RCM9600	10.0.91.47	fe80::210:74ff:feb0:cd95
RCM-CN9000	10.0.91.6	fe80::e615:f6ff:fe7a:3f89
석역 발	10.0.90.62	fe80::e615:f6ff:fe7a:43b8
RCM-CN9000_90233	10.0.90.233	fe80::6a5e:1cff:fee8:5e78
RCM-CN9600	10.0.90.203	fe80::4206:a0ff:fe30:d50
CN9600	10.0.91.79	fe80::4206:a0ff:fe30:e385

- b) Specify the port for communicating with the added device.
 - c) Enter valid credentials to authenticate and add the selected device.
4. Click **Add**. The selected device is added to the device list.

Updating Device Credentials

When the login credentials of a managed device change, follow the steps below to update the login credentials on the console station.

1. From the console station's management console, click  **Device Management**. The device list appears.



The screenshot shows the 'Device Management' interface. At the top, there is a blue header with a back arrow and the title 'Device Management'. Below the header are three buttons: 'Add', 'Edit', and 'Delete'. The main area contains a table with the following data:

	Device Name	Devices	IP Address
1		KVM	10.0.91.42
2	KG0032	KVM	10.0.91.112
3	KG0032_ab	KVM	10.0.91.64
4	RCM-CN9600	KVM	10.0.90.203

2. Double-click a device from the device list. Alternatively click to select a device from the device list, and then click the **Edit** button. The Modify Device dialog box appears.



The screenshot shows the 'Modify Device' dialog box. It contains the following fields and controls:

- IP Address:** 10.0.90.203
- Port:** 9000
- User Name:** administrator
- Password:** [Masked with 10 dots]
- Buttons:** Save (blue), Cancel (grey)

3. Enter valid credentials.
4. Click **Save** to apply the changes.

Deleting a Device

1. From the console station's management console, click  **Device Management**. The device list appears.



The screenshot shows the 'Device Management' interface. At the top, there is a blue header with a back arrow and the text 'Device Management'. Below the header are three buttons: 'Add', 'Edit', and 'Delete'. A table below contains the following data:

	Device Name	Devices	IP Address
1		KVM	10.0.91.42
2	KG0032	KVM	10.0.91.112
3	KG0032_ab	KVM	10.0.91.64
4	RCM-CN9600	KVM	10.0.90.203

2. Click to select a device from the device list.

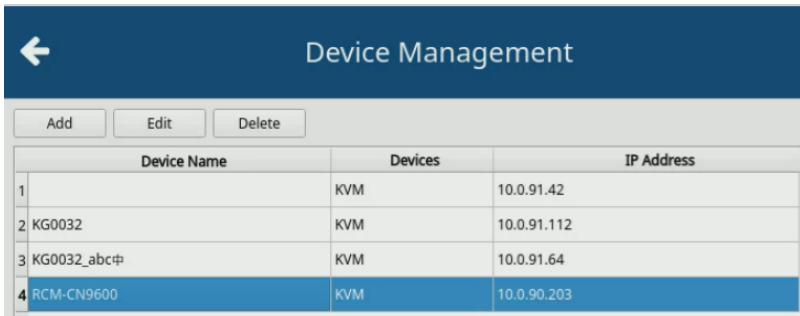

The screenshot shows the 'Device Management' interface, identical to the previous one, but with the fourth row of the table highlighted in blue, indicating it is selected.

	Device Name	Devices	IP Address
1		KVM	10.0.91.42
2	KG0032	KVM	10.0.91.112
3	KG0032_abcφ	KVM	10.0.91.64
4	RCM-CN9600	KVM	10.0.90.203

3. Click the **Delete** button. A confirmation dialog box appears.
4. Click **Yes** to confirm and remove the device from the list.

Chapter 5

System Configuration

Overview

This chapter describes how system settings are organized in the KA8585's management console and how they can be used to support reliable operation, management, and maintenance of the console station.

Account Management

User Accounts

Adding a User Account

1. From the console station's management console, go to **User Management > Users**. This screen appears.

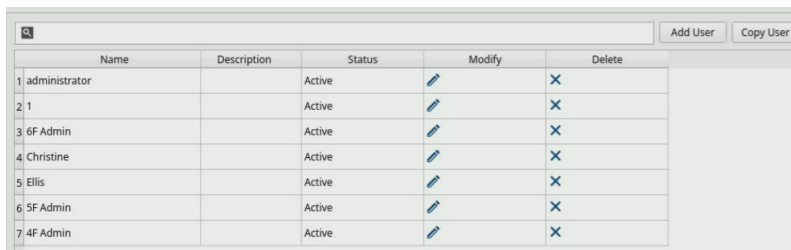

The screenshot shows a web-based user management interface. At the top right, there are buttons for 'Add User' and 'Copy User'. Below these is a table with columns for Name, Description, Status, Modify, and Delete. The table contains seven rows of user accounts, all with a status of 'Active'.

	Name	Description	Status	Modify	Delete
1	administrator		Active		
2	1		Active		
3	6F Admin		Active		
4	Christine		Active		
5	Ellis		Active		
6	5F Admin		Active		
7	4F Admin		Active		

2. Click **Add User**. This screen appears.

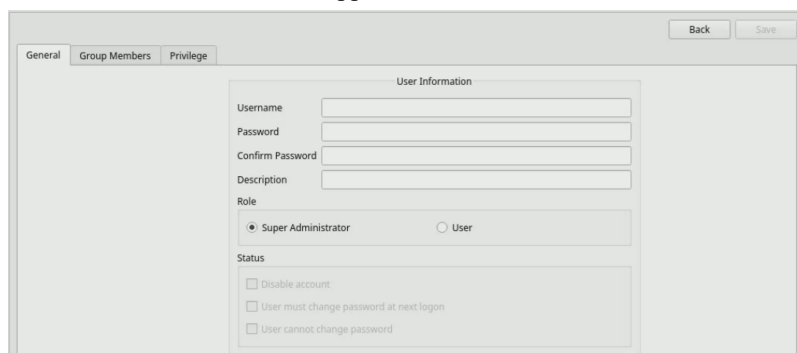

The screenshot shows the 'Add User' form. It has tabs for 'General', 'Group Members', and 'Privilege', with 'General' selected. There are 'Back' and 'Save' buttons at the top right. The form is titled 'User Information' and contains the following fields:

- Username:
- Password:
- Confirm Password:
- Description:
- Role: Super Administrator User
- Status: Disable account
- User must change password at next logon
- User cannot change password

3. In the **General** tab, configure the following settings.
 - a) Enter the username, password, and a description (optional).
 - b) For the role, select between Super **Administrator** or **User**. With a user role, you can keep the account disabled or regulate password usage.
 - ◆ **Disable account:** Create the account but disable it for now.
 - ◆ **User must change password at next login**
 - ◆ **User cannot change password**
4. (Optional) To assign the user to a group, thereby granting access privileges already configured for the group, add one or more groups for the account.
 - a) Click the **Group Members** tab.
 - b) To add a group, double-click a group to move it to the Selected column. To remove a selected group, double-click it to move it back to the Available column. Alternatively use the arrow buttons to add and remove your selection.
5. (Optional) To add more access privileges, configure the privileges in the **Privileges** tab.

Note: Make sure to grant access privileges for this user to see inputs added to the console station. Without setting up access privileges, the user will only be allowed to log in remote devices via the login credentials entered in the Device Management page (page 24).

- a) Click the **Privileges** tab. The following screen appears.

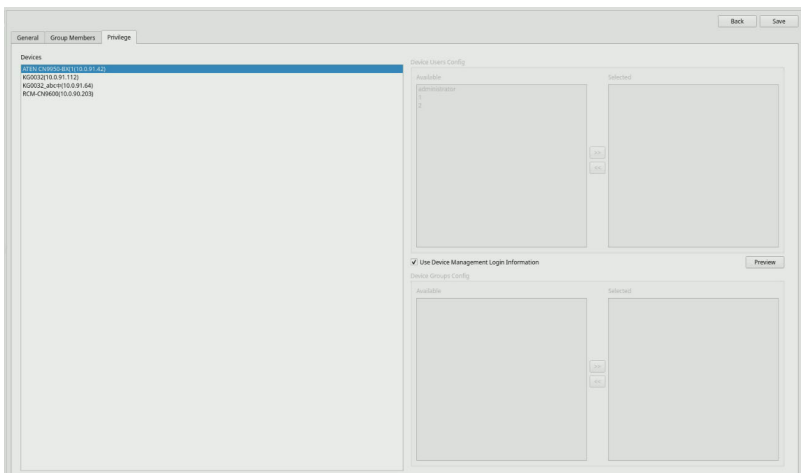

The Devices column lists all remote devices added to the console station. The Device Users Config and Device Groups Config sections list the user and group accounts created on the selected remote device.

- b) Unselect the **Use Device Management Login Information** to allow configuration.
- c) Under the Device Users Config and Device Groups Config columns, double-click one or more user and/or group accounts to add them.

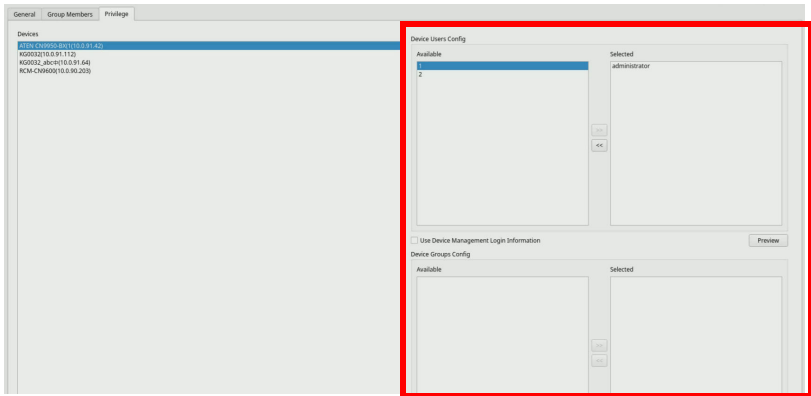

- d) Click **Preview** to verify the setup. A summary of access privileges appears.

Preview			
Name	Access	USB	Config
<ul style="list-style-type: none"> ATEN CN9950-BX(1) <ul style="list-style-type: none"> [01] [17] COM1 	Full access	Full access	Permitted
	Full access	Full access	Permitted

- e) Enable **Use Device Management Login Information** to save the configuration.
6. Click **Save**.

Modifying a User Account

From the user list, click to select a user, and click  to modify the settings. For full details about the settings, see *Adding a User Account*, page 28.

Duplicating a User Account

From the user list, click to select a user and click **Copy User**. All configuration of the selected user is duplicated and the General tab of the user appears. Continue to modify the username, password, and other settings as needed. For full details about the settings, see *Adding a User Account*, page 28.

Deleting a User Account

From the user list, click to select a user and click  to delete the user.

Group Accounts

Adding a Group Account

1. From the console station's management console, go to **User Management > Groups**. This screen appears.

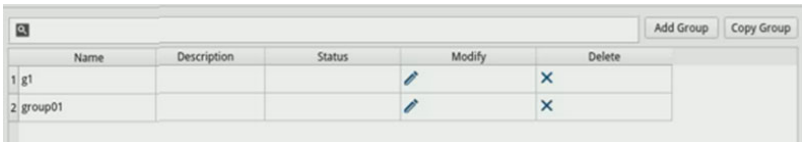

2. Click **Add Group**. This screen appears.



3. Configure the group settings.
 - ◆ **Name:** Provide a name to the group.
 - ◆ **Description:** (Optional) Add a description to distinguish the group.
4. In the **Members** tab, add one or more users to the group.
 - a) Click the **Group Members** tab.
 - b) To add a group, double-click the group to move it to the Select column. To remove a selected group, double-click it to move it back to the Available column. Alternatively use the arrow buttons to add and remove your selection.

5. In the **Devices** tab, configure the access privileges for the group.
- a) Click the **Devices** tab. The following screen appears.

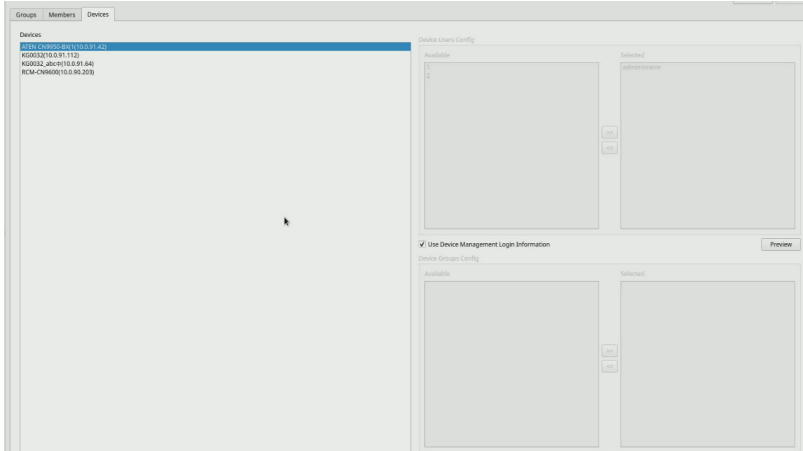

The Devices column lists all remote devices added to the console station. The Device Users Config and Device Groups Config sections list the user and group accounts created on the selected remote device.

- b) Unselect the **Use Device Management Login Information** to allow configuration.
- c) Under the Device Users Config and Device Groups Config columns, double-click one or more user and/or group accounts to add them.

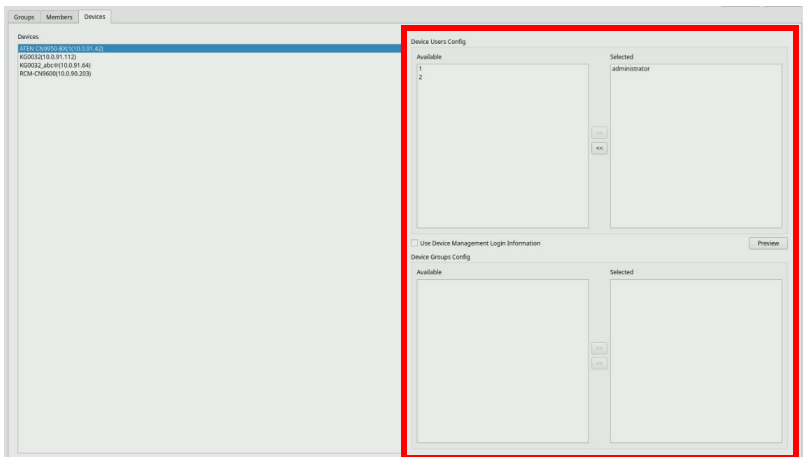

- d) Click **Preview** to verify the setup. A summary of access privileges appears.

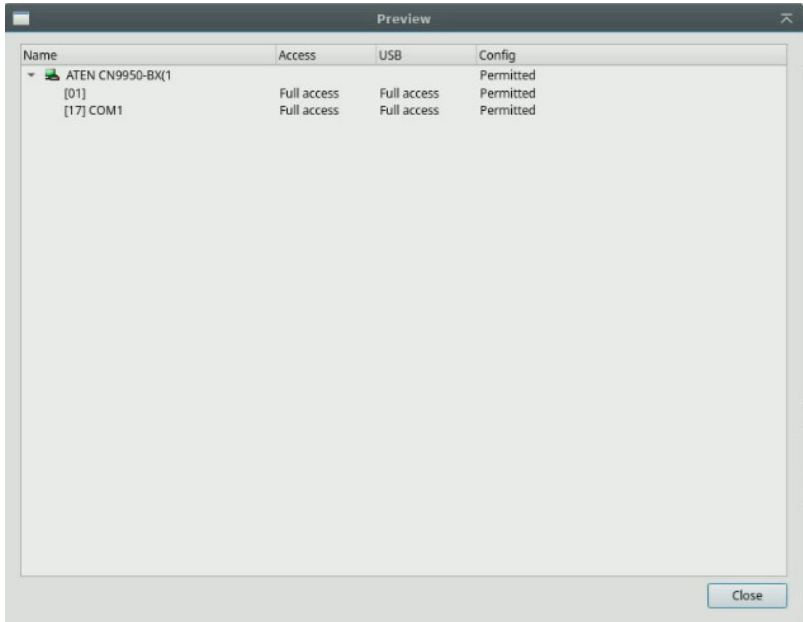

The screenshot shows a window titled "Preview" with a table of access privileges. The table has four columns: Name, Access, USB, and Config. The data is as follows:

Name	Access	USB	Config
ATEN CN9950-BX(1)	Full access	Full access	Permitted
[01]	Full access	Full access	Permitted
[17] COM1	Full access	Full access	Permitted

A "Close" button is located at the bottom right of the window.

- e) Enable **Use Device Management Login Information** to save the configuration.
6. Click **Save** to apply the settings.

Account Policy

Use the Account Polity settings to adjust username/password complexity and password history setup. To access these settings, go to **User Management > Account Policy**.

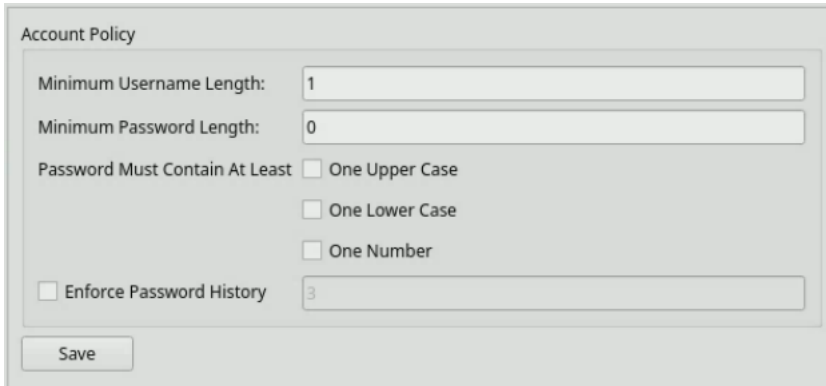

The screenshot shows a configuration window titled "Account Policy". It contains the following fields and options:

- Minimum Username Length:** A text input field containing the value "1".
- Minimum Password Length:** A text input field containing the value "0".
- Password Must Contain At Least:** A group of three checkboxes:
 - One Upper Case
 - One Lower Case
 - One Number
- Enforce Password History:** A checkbox that is currently unchecked, followed by a text input field containing the value "3".

At the bottom left of the window is a "Save" button.

- ◆ **Minimum Username Length:** Type in the minimum number of characters allowed for an account username.
- ◆ **Minimum Password Length:** Type in the minimum number of characters allowed for an account password.
- ◆ **Password Must Contain At Least:** Click to enable/disable requirements (**one upper case, one lower case, or one number**) for an account password.
- ◆ **Enforce Password History:** Enable this setting for the console station to remember previously used passwords and forbid repeated usage. Type the number of previously used passwords that the system remembers.

System Management

Checking General System Settings

To check general system settings of your console station, such as the device name, firmware version, IP addresses, and other network settings

1. Click  from the console station's management console.
2. Go to **System Management > System Information**. A table of settings appears.

Device Name	KA8585
MAC Address 1	00-30-18-14-9C-5E
MAC Address 2	00-30-18-14-9C-5F
Firmware Version	V1.0.062 Build20251205
IP Address 1	10.0.91.77
Subnet Mask 1	255.255.252.0
Gateway 1	10.0.90.254
Preferred DNS server 1	10.0.1.6
Alternate DNS server 1	10.0.1.7
IPv6 Address 1	::
IPv6 Subnet Prefix Length 1	0
IP Address 2	192.168.0.61
Subnet Mask 2	255.255.255.0
Gateway 2	192.168.0.1
IPv6 Address 2	::
IPv6 Subnet Prefix Length 2	0

Network Settings

To configure the console station's network settings, click  from the console station's management console, and then go to **System Management > Network**.

◆ IP Installer

IP Installer is an external, Windows-based utility that can be used for assigning IP addresses to the console station.

- ◆ **Enabled, view-only, disabled:** Select one of these options to specify whether the console station's IP addresses can be viewed and modified (**Enabled**), viewed only, or neither viewed nor modified (**Disabled**).
- ◆ **Redundant NIC:** The console station has two network interfaces. With **Redundant NIC** enabled (default), a single IP address (configured on Network Adapter 1) is used in an active-standby configuration. The secondary interface remains inactive until a failure

occurs on the primary interface, at which point traffic automatically switches to the secondary interface.

- ◆ **IPv4 Settings**

- ◆ **Obtain IP Address Automatically [DHCP]:** Select this option to use a dynamic IP address.
- ◆ **Set IP Address Manually [Fixed IP]:** Select this option to use a fixed IP address. After enabling the setting, enter the IP Address, Subnet Mask, and Gateway.
- ◆ **DNS Server:** Configure the DNS server address.
 - ◆ **Obtain DNS Server Address Automatically:** Select this option to use a dynamic DNS server address.
 - ◆ **Set DNS Server Address Manually:** Select this option to set a fixed DNS server address. Also configure the preferred and alternate DNS server address fields.

- ◆ **IPv6 Settings**

- ◆ **Obtain IPv6 Address Automatically [DHCP]:** Select this option to use a dynamic IP address.
- ◆ **Set IPv6 Address Manually [Fixed IP]:** Select this option to use a fixed IP address. After enabling the setting, enter the IPv6 Address, IPv6 Subnet Prefix Length, and Gateway.
- ◆ **DNS Server:** Configure the DNS server address.
 - ◆ **Obtain DNS Server Address Automatically:** Select this option to use a dynamic DNS server address.
 - ◆ **Set DNS Server Address Manually:** Select this option to set a fixed DNS server address. Also configure the preferred and alternate DNS server address fields.

ANMS

The ANMS (Autonomic Network Management System) page contains settings related to account authentication—RADIUS server and AD/LDAP. To access this page, click  from the console station's management console, and then go to **System Management > ANMS**.

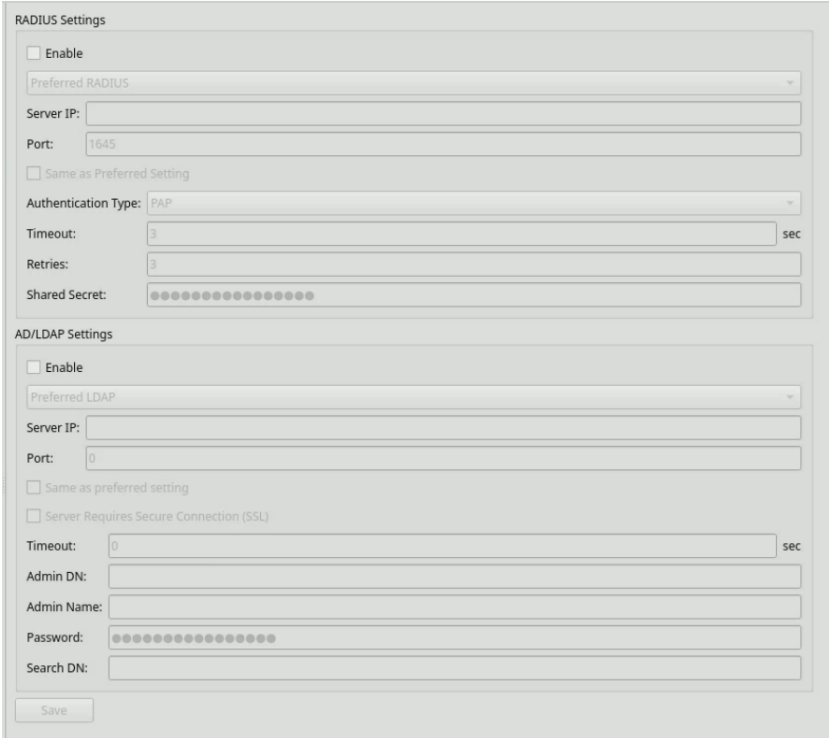

The screenshot displays the ANMS configuration interface, divided into two main sections: RADIUS Settings and AD/LDAP Settings.

RADIUS Settings:

- Enable
- Preferred RADIUS: [Dropdown menu]
- Server IP: [Text input field]
- Port: [Text input field, value: 1645]
- Same as Preferred Setting
- Authentication Type: [Dropdown menu, value: PAP]
- Timeout: [Text input field, value: 3] sec
- Retries: [Text input field, value: 3]
- Shared Secret: [Text input field with masked characters]

AD/LDAP Settings:

- Enable
- Preferred LDAP: [Dropdown menu]
- Server IP: [Text input field]
- Port: [Text input field, value: 0]
- Same as preferred setting
- Server Requires Secure Connection (SSL)
- Timeout: [Text input field, value: 0] sec
- Admin DN: [Text input field]
- Admin Name: [Text input field]
- Password: [Text input field with masked characters]
- Search DN: [Text input field]

A "Save" button is located at the bottom left of the configuration area.

◆ RADIUS

Enable RADIUS to authenticate logins of the console station through a RADIUS sever.

- ◆ **Enable:** Select **Enable** and use the drop-down list to select either **Preferred RADIUS** or **Alternate RADIUS**.
- ◆ **Server IP & Port:** Fill in the IP addresses and service port numbers for the Preferred RADIUS server. You can use either the IPv4 address, the IPv6 address, or the domain name in the IP fields.
- ◆ **Same with preferred settings:** Select this option to apply the preferred RADIUS authentication type, timeout, retries, and shared secret settings to the alternate RADIUS.

- ◆ **Authentication Type:** Select an authentication method depending on your security requirements, system capabilities, and compatibility constraints. Select **CHAP** for higher security if possible.
- ◆ **Timeout:** Set the duration for which the console station waits for the RADIUS server to respond before timing out.
- ◆ **Retries:** Set the number of retries allowed from the RADIUS server.
- ◆ **Shared secret:** Type in a string of characters to be used for authentication between the console station and the RADIUS server. Make sure the string meets the following requirements:
 - ◆ should contain at least 6 characters
 - ◆ only uses these special characters (if they are used at all):
.,{}:|~!@#%&_=><*+?\$-()[]/^.
- ◆ **AD/LDAP**

Enable AD/LDAP to authenticate logins of the console station through a Active Directory (AD) or Lightweight Directory Access Protocol (LDAP).

 - ◆ **Enable:** Select **Enable** and use the drop-down list to select either **Preferred LDAP** or **Alternative LDAP**.
 - ◆ **Server IP & Port:** Fill in the IP addresses and service port numbers for the selected server. You can use either the IPv4 address, the IPv6 address, or the domain name in the IP fields.
 - ◆ **Same with preferred settings:** Select this option to apply the preferred LDAP authentication type, timeout, retries, and shared secret settings to the alternate LDAP.
 - ◆ **Server requires secure connection (SSL):** Select this setting to enable SSL communication.
 - ◆ **Admin DN:** Type in the full administrator distinguished name, i.e. the account name on the console server used to login to the directory for administrative or lookup purposes. This account must have permissions to search users and groups. For example,
 - ◆ **Admin Name:** Type in the simplified account name used to log in the directory.
 - ◆ **Password:** Type the password of the account your entered for Admin DN.
 - ◆ **Search DN:** Define where in the directory tree the console station searches for users and groups.

Security

Use the Security page to configure number of allowed logins and the ICMP setting. To access this page, click  from the console station's management console, and then go to **System Management > Security**.

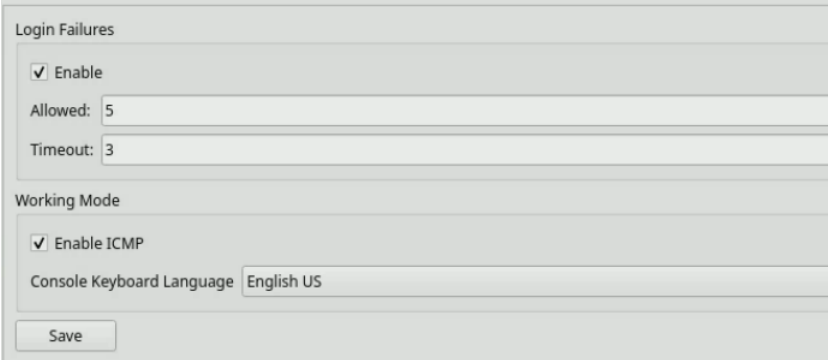

Login Failures

Enable

Allowed: 5

Timeout: 3

Working Mode

Enable ICMP

Console Keyboard Language English US

Save

- ◆ **Login Failures**
 - ◆ **Allowed:** Type in the allowed number of login retries.
 - ◆ **Timeout:** Type in the duration of inactivity (in minutes) before the timeout.
- ◆ **Working Mode**
 - ◆ **Enable ICMP:** Enable ICMP to send control and error messages between the console station and its connected devices.
 - ◆ **Console Keyboard Language:** Use the drop-down menu to select an interface language for the console keyboard.

Date & Time

Use the Date / Time Settings page to configure the system time. To access this page, click  from the console station's management console, and then go to **System Management > Date Time Settings**.

Time Zone

(GMT-12:00) Eniwetok Kwajalein ▼

Daylight Saving Time

Date

◀ December, 2025 ▶

Sun	Mon	Tue	Wed	Thu	Fri	Sat
30	1	2	3	4	5	6
7	8	9	10	11	12	13
14	15	16	17	18	19	20
21	22	23	24	25	26	27
28	29	30	31	1	2	3
4	5	6	7	8	9	10

Time

14 : 21 : 11

Network Time

Enable auto adjustment

Preferred time server

AU | ntp1.cs.mu.OZ.AU ▼

Preferred custom server IP

Alternate time server

AU | ntp1.cs.mu.OZ.AU ▼

Alternate custom server IP

Adjust time every days Adjust Time Now

- ◆ **Time Zone:** Use the drop-down menu to select a time zone.
- ◆ **Daylight Saving Time:** Enable this setting for the console station to adjust its system time forward or backward according to the DST rules of the selected time zone.
- ◆ **Time:** Use this setting to configure a specific system time.
- ◆ **Network Time:** Enable this function for the console station to automatically adjust its time with a specified time source at a specified interval.

- ◆ Set up a preferred network time server by selecting a server from the drop-down menu and optionally specify the server IP address.
- ◆ Optionally set up an alternate time server by selecting **Alternate time server**, selecting a server from the drop-down menu, and specifying the server IP address.
- ◆ **Adjust time every:** Enter the number of days the console station synchronizes with the specify network time server.
- ◆ **Adjust Time Now:** Click this button for the console station to synchronize with the specified network time server immediately.

Maintenance

Upgrading the System Firmware

To upgrade the console station:

1. Download the firmware file from the product page.
2. Click  from the management console, and go to **Maintenance > Upgrade Main Firmware**. This screen appears.

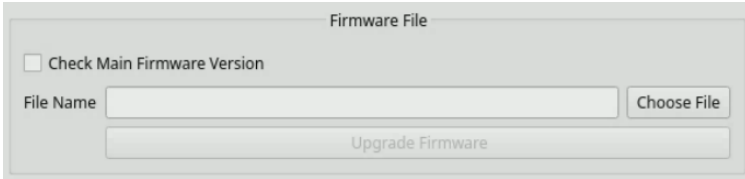

3. (Optional) Enable **Check Main Firmware Version** for the system to display a reminder if the browsed firmware is older than your currently used one.
4. Click **Choose File** to browse for a firmware file.
5. Click **Upgrade Firmware** to start the upgrade.

Configuration Backup

1. Click  from the management console, and go to **Maintenance > Backup/Restore**. This screen appears.

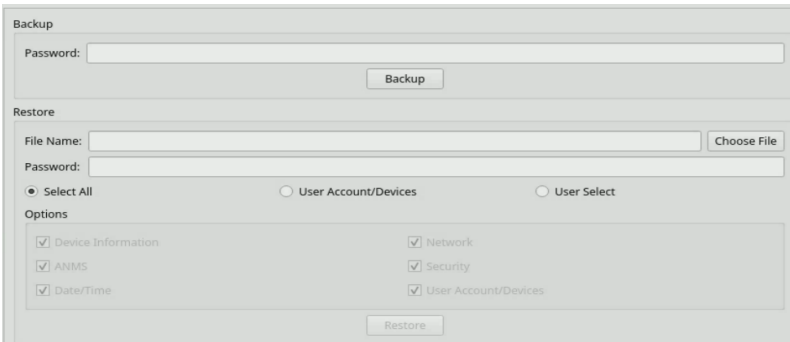

2. Type in the account password and click **Backup**.

3. In the pop-up window, specify the save location and click **Save**. A .cfg file is saved.

Restoring System Configuration with a Previous Backup

1. Click  from the management console, and go to **Maintenance > Backup/Restore**. This screen appears.

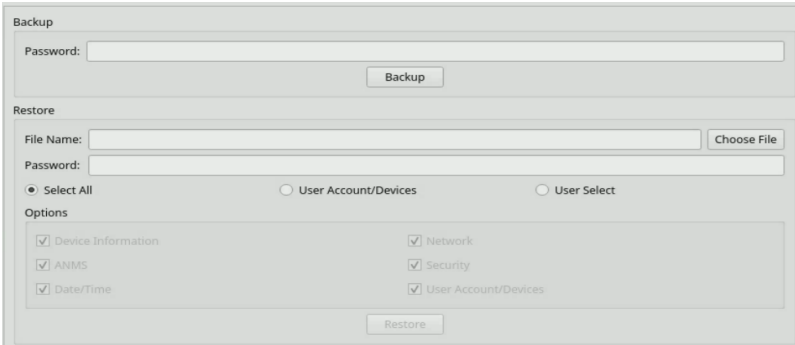

The screenshot shows a web-based configuration interface for system backup and restore. It is titled "Backup/Restore" and is split into two main sections. The "Backup" section at the top contains a "Password:" input field and a "Backup" button. The "Restore" section below it contains a "File Name:" input field with a "Choose File" button, another "Password:" input field, and three radio button options: "Select All" (which is selected), "User Account/Devices", and "User Select". Underneath the radio buttons is an "Options" section with a grid of checkboxes: "Device Information", "ANMS", "Data/Time", "Network", "Security", and "User Account/Devices", all of which are checked. A "Restore" button is located at the bottom center of the "Restore" section.

2. In the Restore section, click **Choose File** to browse for a previously saved configuration file (.cfg).
3. Type in the account password.
4. (Optional) Select the settings to restore with the configuration file.
 - ◆ **Select All:** This restores all system settings, including the network setting.
 - ◆ **User Account/Devices:** This restores just the account and device settings.
 - ◆ **User Select:** Select this option to customize.
5. Click **Restore** to start the process.

Terminal

The console station supports command line interface that allows the user to test connectivity, troubleshoot, configure system volume, and set prompt string. To access the terminal page, click  from the management console, and go to **Maintenance > Terminal**. To display available commands, type **help** and then press **<Enter>**.

Supported Commands

Command	Function & Syntax
Hint: To display usage information for a command, type the command in the terminal page and press <Enter> . For example, setprompt <Enter>	
help	<ul style="list-style-type: none"> ◆ Function: Displays the supported commands and their functions. ◆ Syntax: <code>help <Enter></code>
ping	<ul style="list-style-type: none"> ◆ Function: Pings a device connected to the console station until stopped with <Ctrl> + C ◆ Syntax: <code>ping -t <Enter></code> t: IP address of the target device ◆ Example: To ping a connected device with the IP address of 10.0.91.42, enter this command: <code>ping -10.0.91.42 <Enter></code>
clear	<ul style="list-style-type: none"> ◆ Function: Clears the terminal screen. ◆ Syntax: <code>clear <Enter></code>
selfdiagnostic	<ul style="list-style-type: none"> ◆ Function: Displays general system information, network status, and network statistics (e.g. tx/rx packets, tx/rx bytes). ◆ Syntax: <code>selfdiagnostic <Enter></code>

Command	Function & Syntax
setprompt	<ul style="list-style-type: none">◆ Function: Sets the prompt text.◆ Syntax: <code>setprompt [text] <Enter></code> text: Type the prompt text or symbol and remove the square brackets.◆ Example: To set the prompt text/symbol as “#”, enter this command: <code>setprompt # <Enter></code>
setvol	<ul style="list-style-type: none">◆ Function: Sets the volume of the speaker connected to the console station, with 100% as the loudest, and 0% as mute.◆ Syntax: <code>setvol [volume] <Enter></code> volume: Type a volume number. The valid range is 0–100%.◆ Example: To set the volume to 15%, enter this command: <code>setvol 15 <Enter></code>

Configuring the Monitor Arrangement

You can define installed monitors as vertically or horizontally arranged. The illustration below shows that the console station is installed with two horizontally arranged HDMI monitors.

To configure arrangement of the connected displays:

1. Click  from the management console, and go to **Maintenance > Display Setting**. This page appears.

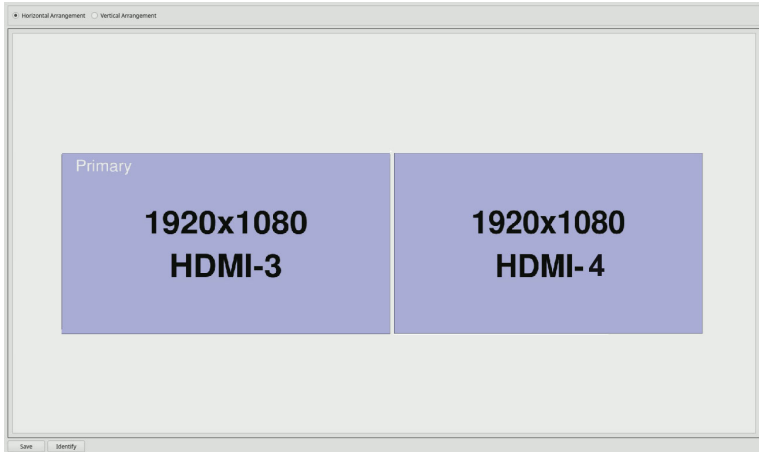

2. Select **Horizontal Arrangement** or **Vertical Arrangement** to define the physical setup of the displays.
3. The console station identifies the monitor on the left/top of the arrangement as the primary monitor. To change the primary monitor, drag-and-drop your target monitor to the left/top of the arrangement. It should then be indicated with “Primary”.
4. To identify the interface and port to which a monitor is connected, click **Identify**. The interface and port number is indicated at the bottom-left corner of the connected monitors. For example, “HDMI-3” appears briefly to show that a display is connected to port 3, an HDMI port.

Resetting the System to Default Settings

1. Click  from the management console, and go to **Maintenance > System Operation**. This screen appears.

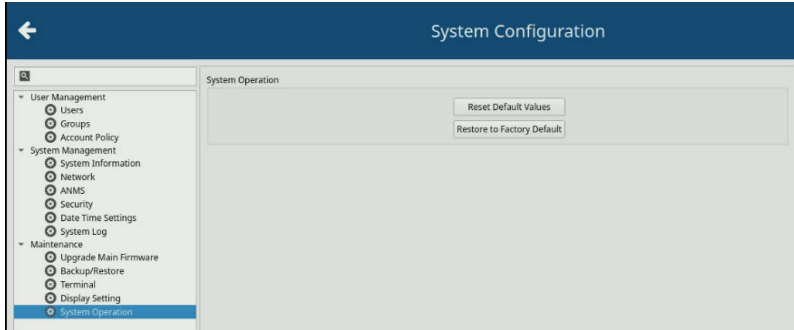

2. Depending on your needs,
 - ◆ To reset system settings to defaults but retain the current network settings, click **Reset Default Values**.
 - ◆ To reset system, network, account settings to defaults, click **Restore to Factory Default**. You will be prompted to enter a password and then pin the **Reset** button (on the front panel of the console station) once to start the reset.

System Maintenance

Changing the Password

To change the password, click  from the main screen, and click **Change Password**. Follow the on-screen instructions to provide the current password and a new password to apply the change.

Rebooting the Console Station

Click  from the main screen, and click **Reboot**. Click **Yes** to confirm. The console station starts the reboot shortly.

User Preferences

You can customize the following settings of the console station through the User Preferences menu:

- ◆ language of the management console
- ◆ Auto logout time
- ◆ Array monitoring settings
- ◆ Control mode settings
- ◆ Display scale

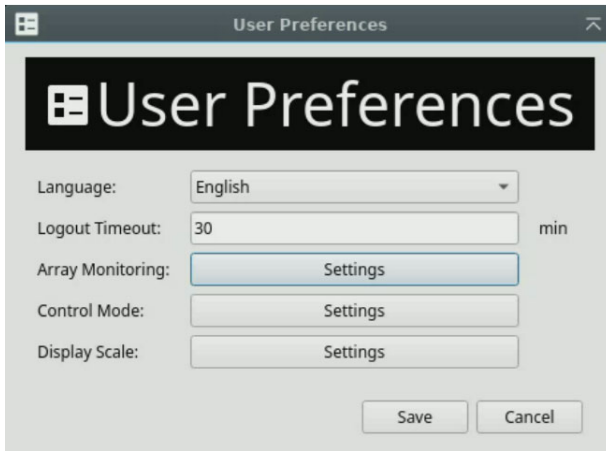

Interface Language

To change the password:

1. Click  from the main screen, and click **User Preferences**. The User Preferences window appears.
2. From the Language drop-down menu, click to select a language.
3. Click **Save** to apply the change.

Auto Logout

The console station automatically logs out after a period of inactivity. To change the duration of timeout setting, follow the steps below.

1. Click  from the main screen, and click **User Preferences**. The User Preferences window appears.
2. From the Logout Timeout drop-down menu, click to select a time duration.
3. Click **Save** to apply the change.

Array Monitoring Settings

To modify array monitoring preferences:

1. Click  from the main screen, and click **User Preferences**. This window appears.

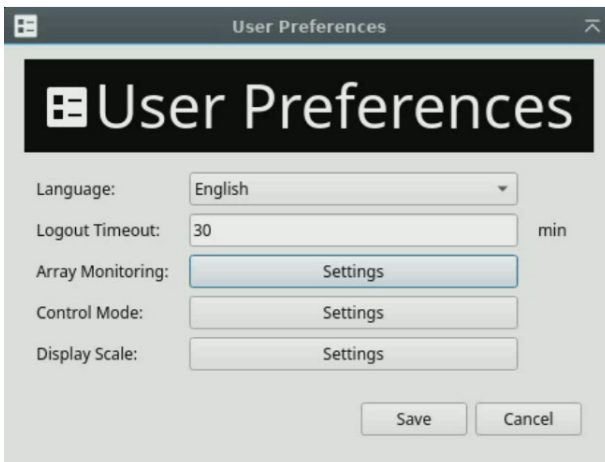

- From the Array Monitoring field, click **Settings**. This window appears.

Array Monitoring Settings

Caption

Allow

Format: Device Name/Port Name

?

Position: Top-Left

Allow auto hide caption

Font Size: 12

Color: Edit

Allow Text Shadow: Edit

Allow Outline: Edit

Background Color: Edit

Transparency: 128

Alert Color: Edit ...

Grid

Grid Line Size: 1 px

Grid Line Color: Edit

Grid Fill Color: Edit

Other

Flip Duration: 3 secs

Restore defaults Save Cancel

- Configure the settings as needed.

Caption: Use this group of settings to configure the caption in each Array Monitoring grid. Click **Allow** to configure the caption settings.

- ◆ **Format:** Specify the format of the caption. Select between **Port Name**, **Device Name/Port Name**, or **Customize** (and type the format in the field below).
- ◆ **Position:** Specify where on the grid to display the caption.

- ◆ **Allow auto hide caption:** Enable this setting to automatically hide the device and port name on each grid when the console mouse is not in the grid.

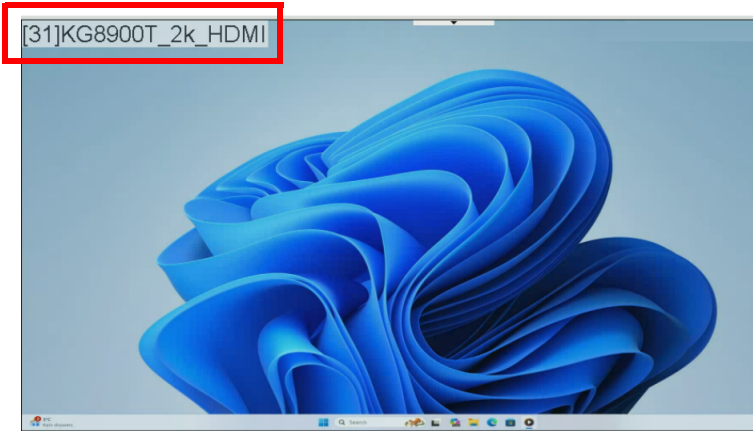

- ◆ **Font size:** Specify the font size.
- ◆ **Color:** Click **Edit** to open the color palette window to configure the caption color.
 - ◆ **Allow Text Shadow:** Enable this setting to add shadow to the caption. Click **Edit** to change the color of the shadow.
 - ◆ **Allow Outline:** Enable this setting to add an outline to the caption. Click **Edit** to change the color of the outline.
 - ◆ **Background Color:** Enable this setting to configure the background color of the caption. Click **Edit** to change the color of the outline. Use the **Transparency** slider bar to adjust the opacity.
 - ◆ **Alert Color:** Configure the color, font size, and background color (along with its transparency) of alert messages. Click **Edit** to configure the background color. Click the ellipsis button to access the font size and background color (along with its transparency) settings.
- ◆ **Grid:** Use this group of settings to configure the thickness and color of the grid lines, and the fill color of the grids.
- ◆ **Flip Duration:** Specify the refresh frequency of the displayed information.

To restore the above settings to defaults, click the **Restore defaults** button.

4. Click **Save** to apply the changes.

Control Mode Settings

To modify Control Mode preferences:

1. Click  from the main screen, and click **User Preferences**. This window appears.

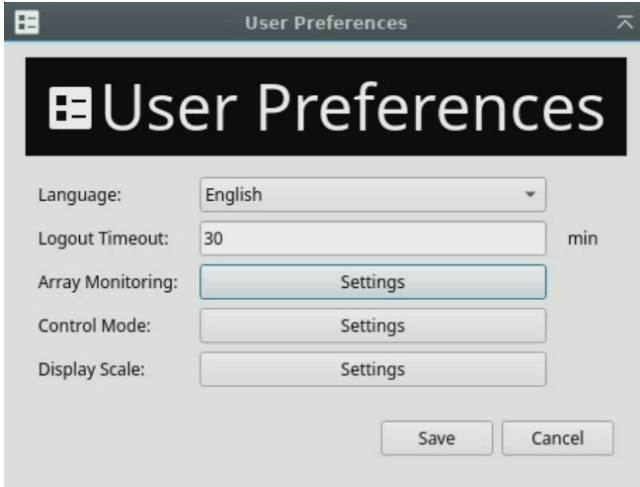

2. From the Control Mode field, click **Settings**. This window appears.

Control Mode Settings

Caption

Allow
Format: Device Name/Port Name
[] ?

Position: Top-Left

Allow auto hide caption

Font Size: 12

Color: Edit

Allow Text Shadow: Edit

Allow Outline: Edit

Background Color: Edit

Transparency: [] 255

Alert Color: Edit []

Border

Allow Border

Size: 1 px

Border Line Color: Edit

Background Color: Edit

Restore defaults Save Cancel

3. Configure the settings as needed.

Caption: Use this group of settings to configure the caption in each Control Mode grid. Click **Allow** to configure the caption settings.

- ◆ **Format:** Specify the format of the caption. Select between **Port Name**, **Device Name/Port Name**, or **Customize** (and type the format in the field below).

- ◆ **Position:** Specify where on the grid to display the caption.
- ◆ **Allow auto hide caption:** Enable this setting to automatically hide the device and port name on each grid when the console mouse is not in the grid.



- ◆ **Font size:** Specify the font size.
- ◆ **Color:** Click **Edit** to open the color palette window to configure the caption color.
 - ◆ **Allow Text Shadow:** Enable this setting to add shadow to the caption. Click **Edit** to change the color of the shadow.
 - ◆ **Allow Outline:** Enable this setting to add an outline to the caption. Click **Edit** to change the color of the outline.
 - ◆ **Background Color:** Enable this setting to configure the background color of the caption. Click **Edit** to change the color of the outline. Use the **Transparency** slider bar to adjust the opacity.
 - ◆ **Alert Color:** Configure the color, font size, and background color (along with its transparency) of alert messages. Click **Edit** to configure the background color. Click the ellipsis button to access the font size and background color (along with its transparency) settings.
- ◆ **Border:** Use this group of settings to configure the thickness and color of the grid lines, and the background color of the grids.

To reset the above settings to defaults, click the **Restore defaults** button.

4. Click **Save** to apply the changes.

Safety Instructions

General

- ◆ This product is for indoor use only.
- ◆ Read all of these instructions. Save them for future reference.
- ◆ Follow all warnings and instructions marked on the device.
- ◆ Do not place the device on any unstable surface (cart, stand, table, etc.). If the device falls, serious damage will result.
- ◆ Do not use the device near water.
- ◆ Do not place the device near, or over, radiators or heat registers.
- ◆ The device cabinet is provided with slots and openings to allow for adequate ventilation. To ensure reliable operation, and to protect against overheating, these openings must never be blocked or covered.
- ◆ The device should never be placed on a soft surface (bed, sofa, rug, etc.) as this will block its ventilation openings. Likewise, the device should not be placed in a built in enclosure unless adequate ventilation has been provided.
- ◆ Never spill liquid of any kind on the device.
- ◆ Avoid circuit overloads. Before connecting equipment to a circuit, know the power supply's limit and never exceed it. Always review the electrical specifications of a circuit to ensure that you are not creating a dangerous condition or that one doesn't already exist. Circuit overloads can cause a fire and destroy equipment.
- ◆ Unplug the device from the wall outlet before cleaning. Do not use liquid or aerosol cleaners. Use a damp cloth for cleaning.
- ◆ The device should be operated from the type of power source indicated on the marking label. If you are not sure of the type of power available, consult your dealer or local power company.
- ◆ To prevent damage to your installation it is important that all devices are properly grounded.
- ◆ Do not allow anything to rest on the power cord or cables. Route the power cord and cables so that they cannot be stepped on or tripped over.

- ◆ Position system cables and power cables carefully; Be sure that nothing rests on any cables.
- ◆ When connecting or disconnecting power to hot-pluggable power supplies, observe the following guidelines:
 - ◆ Install the power supply before connecting the power cable to the power supply.
 - ◆ Unplug the power cable before removing the power supply.
 - ◆ If the system has multiple sources of power, disconnect power from the system by unplugging all power cables from the power supplies.
- ◆ Never push objects of any kind into or through cabinet slots. They may touch dangerous voltage points or short out parts resulting in a risk of fire or electrical shock.
- ◆ Do not attempt to service the device yourself. Refer all servicing to qualified service personnel.
- ◆ If the following conditions occur, unplug the device from the wall outlet and bring it to qualified service personnel for repair.
 - ◆ The power cord or plug has become damaged or frayed.
 - ◆ Liquid has been spilled into the device.
 - ◆ The device has been exposed to rain or water.
 - ◆ The device has been dropped, or the cabinet has been damaged.
 - ◆ The device exhibits a distinct change in performance, indicating a need for service.
 - ◆ The device does not operate normally when the operating instructions are followed.
- ◆ Only adjust those controls that are covered in the operating instructions. Improper adjustment of other controls may result in damage that will require extensive work by a qualified technician to repair.
- ◆ Additional protection to secure and fix the equipment is needed if the equipment is installed by stacking; by locking it to the rack, screwing it to the frame, or other similar methods.
- ◆ Keep the Cat 5e/6 cable as far away as possible from potential sources of EMI, such as electrical cables, transformers, and light fixtures. Do not tie the cables to electrical conduits or lay the cables on electrical fixtures.

Rack Mounting

- ◆ Before working on the rack, make sure that the stabilizers are secured to the rack, extended to the floor, and that the full weight of the rack rests on

the floor. Install front and side stabilizers on a single rack or front stabilizers for joined multiple racks before working on the rack.

- ◆ Always load the rack from the bottom up, and load the heaviest item in the rack first.
- ◆ Make sure that the rack is level and stable before extending a device from the rack.
- ◆ Use caution when pressing the device rail release latches and sliding a device into or out of a rack; the slide rails can pinch your fingers.
- ◆ After a device is inserted into the rack, carefully extend the rail into a locking position, and then slide the device into the rack.
- ◆ Do not overload the AC supply branch circuit that provides power to the rack. The total rack load should not exceed 80 percent of the branch circuit rating.
- ◆ Make sure that all equipment used on the rack – including power strips and other electrical connectors – is properly grounded.
- ◆ Ensure that proper airflow is provided to devices in the rack.
- ◆ Ensure that the operating ambient temperature of the rack environment does not exceed the maximum ambient temperature specified for the equipment by the manufacturer
- ◆ Do not step on or stand on any device when servicing other devices in a rack.

Technical Support

International

- ◆ For online technical support – including troubleshooting, documentation, and software updates: **<http://eservice.aten.com>**
- ◆ For telephone support, see *Telephone Support* on page iv.

North America

Email Support		support@aten-usa.com
Online Technical Support	Troubleshooting Documentation Software Updates	http://eservice.aten.com
Telephone Support		1-888-999-ATEN ext 4988 1-949-428-1111

When you contact us, please have the following information ready beforehand:

- ◆ Product model number, serial number, and date of purchase.
- ◆ Your computer configuration, including operating system, revision level, expansion cards, and software.
- ◆ Any error messages displayed at the time the error occurred.
- ◆ The sequence of operations that led up to the error.
- ◆ Any other information you feel may be of help.

Specifications

Connectors	
Console Ports	4 x USB Type-A Female (Blue)
	2 x DisplayPort Female (Black)
	2 x HDMI Female (Black)
	1 x Audio line in/out jack (Black)
	1 x DB-9 Male (Black)
Power	1 x Lockable DC Jack (Black)
LAN Ports	2 x RJ-45 (Blue)
Pushbuttons	
Power	1 x Pushbutton
Reset	1 x Pushbutton
LEDs	
Power	1 (Blue)
Storage	1 (Orange)
Power Consumption	
DC 19V:33W:420 BTU/h	
Note:	
<ul style="list-style-type: none"> ◆ The measurement in Watts indicates the typical power consumption of the device with no external loading. ◆ The measurement in BTU/h indicates the power consumption of the device when it is fully loaded. 	
Video Resolution	
Up to 4 * 4096 x 2160 @ 60 Hz	
Latency	
< 50 ms	
Environmental	
Operating Temperature	-10–50 °C
Storage Temperature	-40–85°C
Humidity	10–90% RH, Non-condensing

Physical Properties	
Housing	Metal
Weight	1.34 kg (2.95 lb)
Dimensions (L x W x H)	20.00 x 19.00 x 4.18 cm (7.87 x 7.48 x 1.65 in.)

Troubleshooting

General Operation

Issue	Resolution
I have been given an account, but I am unable to log in.	<ul style="list-style-type: none"> ◆ Make sure that you have correctly specified the username and password. ◆ Make sure that the administrator has given you the necessary permission to access the console station.
Sudden loss of network connection	Close your connection to the console station. Wait approximately 30 seconds, and then log in again.
The sources on my view panels (control mode and array monitoring) are misplaced or shown in incorrect scaling.	<p>This may happen when one or more of the following scenarios occur:</p> <ul style="list-style-type: none"> ◆ frequent replugging of monitors ◆ frequent powering on and off of installed monitors ◆ incompatible monitors
The display on the KA8585 is distorted and performing an Autosync doesn't resolve the problem.	Switch ports to a port with a different resolution, then switch back. If the above didn't resolve the problem, change the resolution and refresh rate for the system running on the port. Afterward, you can either run at the new resolution, or switch back to the original resolution.
My ATEN over IP unit is not listed in the Device List of IP Installer.	<ul style="list-style-type: none"> ◆ Make sure the Broadcast function is enabled from your switch or router in order for the auto-discover to work properly. ◆ Make sure to turn off your firewall and/or antivirus software temporarily in order for the audio-discover to work properly. ◆ Make sure the ATEN over IP unit and the PC are under same network segment.

Issue	Resolution
Sudden restart / reboot of my ATEN over IP unit.	<p>If you have previously performed any of the following actions, ensure they are not repeated.</p> <ul style="list-style-type: none"> ◆ Repeatedly clicking multiple functions and switching between various ports within a short period of time (~< 2 minutes). ◆ Attempting to operate the unit in the middle of saving system settings and/or firmware upgrade.

Mouse Usage

Issue	Resolution
Mouse and/or keyboard are not responding.	Unplug the cable(s) from the console port(s), then plug it/ them back in.
Mouse movement is extremely slow	There is too much data being transferred for your connection to keep up with. Lower the video quality (page 16) so that less video data is transmitted.

ATEN Warranty Policy

The warranty policy may vary by product category and region of purchase. For details, please visit ATEN's official website, select your purchase counties/ regions and then go to the Support Center, or contact your local ATEN sales representative for further assistance.

© Copyright 2026 ATEN® International Co., Ltd.
Released: 2026-01-15

ATEN and the ATEN logo are registered trademarks of ATEN International Co., Ltd. All rights reserved. All other brand names and trademarks are the registered property of their respective owners.