



**KVM Over the NET™
KN9108 / KN9116
User Manual**



FCC Information

This is an FCC Class A product. In a domestic environment this product may cause radio interference in which case the user may be required to take adequate measures.

This equipment has been tested and found to comply with the limits for a Class A digital device, pursuant to Part 15 of the FCC Rules. These limits are designed to provide reasonable protection against harmful interference when the equipment is operated in a commercial environment. This equipment generates, uses and can radiate radio frequency energy and, if not installed and used in accordance with the instruction manual, may cause harmful interference to radio communications. Operation of this equipment in a residential area is likely to cause harmful interference in which case the user will be required to correct the interference at his own expense.

RoHS

This product is RoHS compliant.

SJ/T 11364-2006

The following contains information that relates to China.

部件名称	有毒有害物质或元素					
	铅	汞	镉	六价铬	多溴联苯	多溴二苯醚
电器部件	●	○	○	○	○	○
机构部件	○	○	○	○	○	○

- : 表示该有毒有害物质在该部件所有均质材料中的含量均在SJ/T 11363-2006规定的限量要求之下。
- : 表示符合欧盟的豁免条款, 但该有毒有害物质至少在该部件的某一均质材料中的含量超出SJ/T 11363-2006的限量要求。
- ×: 表示该有毒有害物质至少在该部件的某一均质材料中的含量超出SJ/T 11363-2006的限量要求。



User Information

Online Registration

Be sure to register your product at our online support center:

International	http://support.aten.com
North America	http://www.aten-usa.com/product_registration

Telephone Support

For telephone support, call this number:

International		886-2-8692-6959
China		86-10-5160-1602
Japan		81-3-5323-7178
Korea		82-2-467-6789
North America	ATEN TECH	1-888-999-ATEN
	ATEN NJ	1-732-356-1703
United Kingdom		44-8-4481-58923

User Notice

All information, documentation, and specifications contained in this manual are subject to change without prior notification by the manufacturer. The manufacturer makes no representations or warranties, either expressed or implied, with respect to the contents hereof and specifically disclaims any warranties as to merchantability or fitness for any particular purpose. Any of the manufacturer's software described in this manual is sold or licensed *as is*. Should the programs prove defective following their purchase, the buyer (and not the manufacturer, its distributor, or its dealer), assumes the entire cost of all necessary servicing, repair and any incidental or consequential damages resulting from any defect in the software.

The manufacturer of this system is not responsible for any radio and/or TV interference caused by unauthorized modifications to this device. It is the responsibility of the user to correct such interference.

The manufacturer is not responsible for any damage incurred in the operation of this system if the correct operational voltage setting was not selected prior to operation. PLEASE VERIFY THAT THE VOLTAGE SETTING IS CORRECT BEFORE USE.

Package Contents

The KN9108 / KN9116 package consists of:

- 1 KN9108 or KN9116 KVM Over the NET™ KVM Switch
- 2 Custom KVM Cable Sets
- 1 Power Cord
- 1 Rack Mount Kit
- 1 Foot Pad Set (4 Pads)
- 1 User Manual*
- 1 Quick Start Guide

Check to make sure that all of the components are present and in good order. If anything is missing, or was damaged in shipping, contact your dealer.

Read this manual thoroughly and follow the installation and operation procedures carefully to prevent any damage to the switch or to any other devices on the installation.

* Features may have been added to the KN9108 / KN9116 since this manual was printed. Please visit our website to download the most up to date version of the manual.

Copyright © 2006–2009 ATEN® International Co., Ltd.
Manual Part No. PAPE-0205-4AXG
F/W Version: v1.2.111
Manual Date: 2009-12-09

Altusen and the Altusen logo are registered trademarks of ATEN International Co., Ltd. All rights reserved. All other brand names and trademarks are the registered property of their respective owners.

Contents

FCC Information	ii
SJ/T 11364-2006.	ii
User Information	iii
Online Registration	iii
Telephone Support	iii
User Notice	iii
Package Contents.	iv
About This Manual	x
Overview	x
Conventions	xi
Terminology.	xii
Product Information.	xii

Chapter 1.

Introduction

Features	3
System Requirements.	4
Remote User Computers.	4
Servers	4
Video	5
Cables	5
Operating Systems	6
Browsers	6
Components	7
Front View	7
KN9108:.	7
KN9116:.	7
Rear View	9
KN9108:.	9
KN9116:.	9

Chapter 2.

Hardware Setup

Rack Mounting	12
Installation.	13
Hot Plugging	14
Port ID Numbering	14
Powering Off and Restarting.	14
Port Selection	14

Chapter 3.

Logging In

Overview	15
Local Console Login	15
Browser Login	16
WinClient AP Login	17
.	17

Installation	17
Starting Up	18
The Connection Screen	19
Connecting	21
Operation	22
Java Client AP Login	23
Installation	23
Starting Up	23
Operation	24

Chapter 4.

Administration

The Local Console	25
The Main Page	27
Quick View Ports	27
The List Function	28
Port Names	30
Port Operation	31
The Configuration Page	32
The Session Page	34
The Administration Page	35
General	35
User Management	36
Service Configuration	39
Access Port	39
Log Server	40
Network	41
Network Transfer Rate	41
IP Address	41
DNS Server	41
ANMS	42
RADIUS	42
LDAP / LDAPS	45
CC Management Settings	46
Security	47
Customization	49
Login Failures	49
Working Mode	49
I/O	50
Attributes	50
Timeout	51
Miscellaneous	52
Date/Time	53
The Log Page	54

Chapter 5.**Browser Operation**

Main Web Page	55
Web Page Layout	56
The General Dialog Box	56
Web Page Icons	57
Maintenance	58
Upgrading the Firmware	58
Private Certificate	59
Generating a Self-Signed Certificate	59
Obtaining a CA Signed SSL Server Certificate	59
Importing the Private Certificate	59
Web Page Buttons	60
Activating the WinClient ActiveX Viewer	61
Activating the Java Applet Viewer	62

Chapter 6.**The User Interface**

The Main Page	63
Port Operation	65
The OSD Toolbar	65
Recalling the OSD	65
OSD Hotkey Summary Table	66
The Toolbar Icons	66
Hotkey Operation	67
Auto Scanning	67
Setting the Scan Interval	67
Invoking Auto Scan	67
Pausing Auto Scan	68
Exiting Auto Scan	68
Skip Mode	68
Panel Array Mode	69
Multiuser Operation	71
Control Panel	72
Control Panel Functions	74
Macros	76
Hotkeys	76
Video Settings	82
The Message Board	86
The Button Bar	87
Message Display Panel	87
Compose Panel	87
User List Panel	88
The On-Screen Keyboard	89
Control Panel Configuration	91
WinClient ActiveX	91
Java Applet	91
Mouse Synchronization	93
The Configuration Page	94

Chapter 7.**The Log File**

The Main Screen	97
-----------------------	----

Chapter 8.**The Log Server**

Installation	99
Starting Up	100
The Menu Bar	101
Configure	101
Events	102
Search	102
Maintenance	104
Options	104
Help	104
The Log Server Main Screen	105
Overview	105
The List Panel	106
The Event Panel	106

Chapter 9.**LDAP Server Configuration**

Introduction	107
Install the Windows 2003 Support Tools	107
Install the Active Directory Schema Snap-in	108
Create a Start Menu Shortcut Entry	108
Extend and Update the Active Directory Schema	109
Creating a New Attribute	109
Extending the Object Class With the New Attribute	111
Editing Active Directory Users	113
OpenLDAP	116
OpenLDAP Server Installation	116
OpenLDAP Server Configuration	117
Starting the OpenLDAP Server	118
Customizing the OpenLDAP Schema	119
LDAP DIT Design and LDIF File	120
LDAP Data Structure	120
DIT Creation	121
Using the New Schema	122

Appendix

Safety Instructions	123
General	123
Rack Mounting	125
Technical Support	126
International	126
North America	126
Troubleshooting	127
Administration	127

General Operation	127
The Java Client	128
The Log Server	128
Panel Array Mode	129
The WinClient ActiveX Viewer or AP	129
Sun Systems	130
Mac Systems	130
Additional Mouse Synchronization Procedures	131
Sun / Linux	132
Self-Signed Private Certificates	133
Examples	133
Importing the Files	133
Administrator Login Failure	134
Specifications	135
Compatible Cascade Switches	136
OSD Factory Default Settings	136
About SPHD Connectors	136
Trusted Certificates	137
Overview	137
Installing the Certificate	138
Certificate Trusted	139
Limited Warranty	141

About This Manual

This User Manual is provided to help you get the most from your KN9108 / KN9116. It covers all aspects of installation, configuration and operation. An overview of the information found in the manual is provided below.

Overview

Chapter 1, Introduction, introduces you to the KN9108 / KN9116 System. Its purpose, features and benefits are presented, and its front and back panel components are described.

Chapter 2, Hardware Setup, provides step-by-step instructions for setting up your installation, and explains some basic operation procedures.

Chapter 3, Logging In, describes how to log in to the KN9108 / KN9116 with each of the available access methods: from a local console; an internet browser; a stand-alone Windows application (AP) program; and a stand-alone Java application (AP) program

Chapter 4, Administration, explains the administrative procedures that are employed to configure the KN9108 / KN9116's working environment, as well as how to operate the KN9108 / KN9116 from the local console.

Chapter 5, Browser Operation, describes how to log into the KN9108 / KN9116 with your browser, and explains the functions of the icons and buttons on the KN9108 / KN9116 web page.

Chapter 6, The User Interface, explains how to connect to the KN9108 / KN9116 with the WinClient ActiveX Viewer and Java Applet Viewer software, and describes how to use the OSD to access and control the computers connected to the switch.

Chapter 7, The Log File, shows how to use the log file utility to view all the events that take place on the KN9108 / KN9116.

Chapter 8, The Log Server, explains how to install and configure the Log Server.

Chapter 9, LDAP Server Configuration, explains how to configure the KN9108 / KN9116 for LDAP / LDAPS authentication and authorization with Active Directory or OpenLDAP.

An Appendix, at the end of the manual provides technical and troubleshooting information.

Conventions

This manual uses the following conventions:

- | | |
|---|--|
| Monospaced | Indicates text that you should key in. |
| [] | Indicates keys you should press. For example, [Enter] means to press the Enter key. If keys need to be chorded, they appear together in the same bracket with a plus sign between them: [Ctrl+Alt]. |
| 1. | Numbered lists represent procedures with sequential steps. |
| ◆ | Bullet lists provide information, but do not involve sequential steps. |
| → | Indicates selecting the option (on a menu or dialog box, for example), that comes next. For example, Start → Run means to open the <i>Start</i> menu, and then select <i>Run</i> . |
|  | Indicates critical information. |

Terminology

Throughout the manual we make reference to the terms *Local* and *Remote* in regard to the operators and equipment deployed in a KVM Over the NET™ switch installation. Depending on the point of view, users and servers can be considered *Local* under some circumstances, and *Remote* under others:

- ◆ Switch's Point of View
 - ◆ Remote users – We refer to a user as a *Remote* user when we think of him as someone who logs into the switch over the net from a location that is *remote from the switch*.
 - ◆ Local Console – The keyboard mouse and monitor connected directly to the switch.
 - ◆ Servers – The servers attached to the switch via KVM Adapter Cables.
- ◆ User's Point of View
 - ◆ Local client users – We refer to a user as a *Local client user* when we think of him as sitting at his computer performing operations on the servers connected to the switch that are *remote from him*.
 - ◆ Remote servers – We refer to the servers as *Remote servers* when we think of them from the Local Client User's point of view – since, although they are locally attached to the switch, they are *remote from him*.

When we describe the overall system architecture we are usually speaking from the switch's point of view – in which case the users are considered remote. When we speak about operations users perform via the browser, viewers, and AP programs over the net, we are usually speaking from the user's point of view – in which case the switch and the servers connected to it are considered remote.

Product Information

For information about all ALTUSEN products and how they can help you connect without limits, visit ALTUSEN on the Web or contact an ALTUSEN Authorized Reseller. Visit ALTUSEN on the Web for a list of locations and telephone numbers:

International		http://www.aten.com
North America	ATEN TECH	http://www.aten-usa.com
	ATEN NJ	http://www.aten.com

Chapter 1

Introduction

Overview

The KN9108 / KN9116 is an IP-based KVM control unit that allows both local and remote operators to monitor and access multiple computers from multiple consoles. A single KN9108 / KN9116 can control up to 8 / 16 computers.

Since the KN9108 / KN9116 uses TCP/IP for its communications protocol, it can be accessed from any computer on the Net - whether that computer is located down the hall, down the street, or halfway around the world.

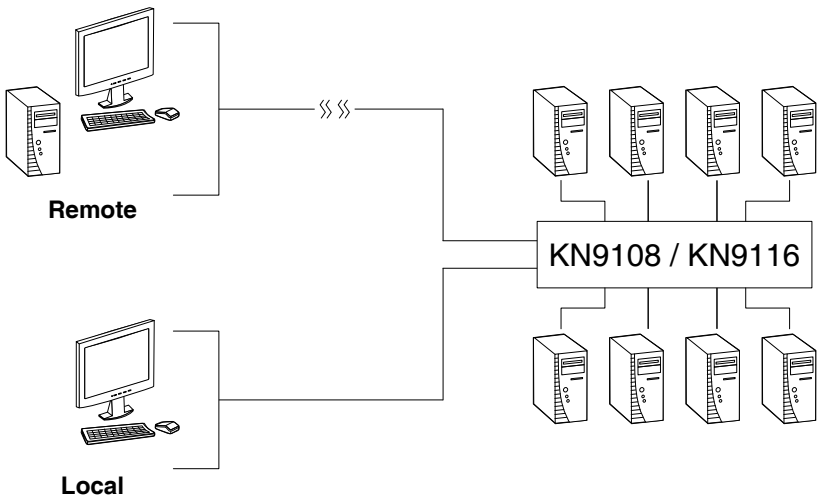

Access to any computer connected to the installation from the local console is easily accomplished by means of a powerful mouse driven graphical OSD (On Screen Display) menu system. A convenient *Auto Scan* feature also permits automatic scanning and monitoring of the activities of all computers running on the installation one by one.

Remote consoles connect to the KN9108 / KN9116 via its IP address. Software utilities are provided with the KN9108 / KN9116 that make remote access smooth and efficient. System administrators can handle a multitude of maintenance tasks with ease - from installing and running GUI applications, to BIOS level troubleshooting, routine monitoring, concurrent maintenance, system administration, rebooting and even pre-booting functions - all from the remote console.

Remote operators can log in from anywhere on the LAN, WAN, or Internet via their browsers. Once they successfully log in, operators can take control using either the *WinClient ActiveX Viewer* or *Java Applet Viewer* utility. Inclusion of a Java-based client ensures that the KN9108 / KN9116 is platform independent, and is able to work with all operating systems.

The client software allows operators to exchange keyboard, video and mouse signals with the computers attached to the KN9108 / KN9116 just as if they were present locally and working on the equipment directly.

With the KN9108 / KN9116's *Panel Array* feature, the video output of up to 8 / 16 computers can be displayed at the same time.

The *Message Board* allows widely separated users to conveniently and instantly communicate with one other. It also includes features that allow users to take control of share ports.

The KN9108 / KN9116 features high density 15 pin CPU port connectors instead of the usual 25 pin connectors. This space-saving innovation allows a full 8 / 16 port switch to be conveniently installed in one unit of system rack space.

Setup is fast and easy - plugging cables into their appropriate ports is all that is entailed. Because the KN9108 / KN9116 intercepts keyboard input directly, there is no need to get involved in complex installation routines or to be concerned with incompatibility problems.

Since the KN9108 / KN9116's firmware is upgradable over the Internet, you can stay current with the latest functionality improvements simply by downloading firmware updates from our website as they become available.

With its advanced security features, the KN9108 / KN9116 is the fastest, most reliable, most cost effective way to remotely access and manage widely distributed multiple computer installations.

Features

- ◆ 8 (KN9108) / 16 (KN9116) port remote access KVM switch – monitor and control up to 8 / 16 computers from a single console
- ◆ Remotely access computers via LAN, WAN, or the Internet – control your installation when and where you want
- ◆ Dual-bus – one local and one remote user can simultaneously control separate ports
- ◆ Internet browser access, WinClient ActiveX Viewer and Java Applet Viewer provided, Java Applet Viewer works with all operating systems*
- ◆ Graphical OSD and toolbars for convenient, user-friendly operation
- ◆ Up to 64 user accounts – up to 32 concurrent logins
- ◆ Panel Array Mode – view all 8 or 16 ports at the same time
- ◆ Message board feature allows logged in users to communicate with each other and allows a user to take exclusive control of the KVM functions
- ◆ On-screen keyboard with multilanguage support
- ◆ BIOS-level access
- ◆ Windows-based Log Server
- ◆ Remote power control for attached Power over the Net™ devices
- ◆ Three level login security: Administrator, User, and Select
- ◆ End session feature – administrators can terminate running sessions
- ◆ Advanced security features include password protection and advanced encryption technologies – 1024 bit RSA, 256 bit AES, 56 bit DES, and 128 bit SSL
- ◆ Enhanced mouse data encryption security to AES and 3DES standards
- ◆ Private CA
- ◆ RADIUS server support
- ◆ Flash upgradable firmware over network connection
- ◆ Ports can be set to Exclusive, Occupy and Share
- ◆ Supports 10Base-T, 100Base-T, TCP/IP, HTTP, and HTTPS
- ◆ High video resolution – up to 1280 x 1024 @ 75Hz; 1600 x 1200 @ 60Hz
- ◆ Front panel can separate from main chassis for convenient front and rear 1U rack mounting

* Browsers must support 128 bit SSL encryption.

System Requirements

Remote User Computers

Remote user computers (also referred to as client computers) are the ones the users log into the switch with from remote locations over the internet (see *Terminology*, page xii). The following equipment must be installed on these computers:

- ◆ For best results we recommend that the computers used to access the switch have at least a P III 1 GHz processor, with their screen resolution set to 1024 x 768.
- ◆ Browsers must support 128 bit SSL encryption.
- ◆ For best results, a network transfer speed of at least 128kbps is recommended.
- ◆ For the WinClient AP Control Panel, DirectX 8 must be present, and at least 90MB of memory must be available after installation.
- ◆ For the Java Client AP Control Panel, the latest version of Sun's Java Runtime Environment (JRE) must be installed, and at least 145MB of memory must be available after installation.
- ◆ For the browser-based WinClient ActiveX Viewer, DirectX 8 must be present, and at least 150MB of memory must be available after installation.
- ◆ For the browser-based Java Applet Viewer the latest version of Sun's Java Runtime Environment (JRE) must be installed, and at least 205MB of memory must be available after installation.
- ◆ For the *Log Server*, you must have the Microsoft Jet OLEDB 4.0 or higher driver installed.

Servers

Servers are the computers connected to the KN9108 / KN9116 (see *Terminology*, page xii). The following equipment must be installed on these servers:

- ◆ A VGA, SVGA, or multisync port.
- ◆ A 6-pin mini-DIN (PS/2) keyboard port.
- ◆ A 6 pin mini-DIN (PS/2) mouse port.

Video

Only the following **non-interlaced** video signals are supported:

Resolution	Refresh Rates
640 x 480	60, 70, 72, 75, 85, 90, 100, 120
720 x 400	70, 75
800 x 600	56, 60, 70, 75, 85, 90, 100, 120
1024 x 768	60, 70, 75, 85, 90, 100
1152 x 864	60, 70, 75, 85
1280 x 1024	60, 70, 75, 85
1600 x 1200	60

Cables

Substandard cables may damage the connected devices or degrade overall performance. If you need additional cables, we strongly recommend that you see your dealer to purchase our high quality CS Custom Cable sets.

Part Number	Length (m)
2L-5201P	1.2
2L-5202P	1.8
2L-5203P	3.0
2L-5206P	6.0
2L-5702P	1.8

Operating Systems

- ◆ Supported operating systems for remote user computers that log into the KVM Over the NET™ switch include Windows 2000 and higher, and those capable of running Sun's Java Runtime Environment (JRE) 6, Update 3, or higher (Linux, Mac, Sun, etc.).
- ◆ Supported operating systems for the servers that are connected to the switch's ports are shown in the table, below:

OS		Version
Windows		2000 and higher
Linux	RedHat	7.1 and higher
	Fedora	Core 2 and higher
	SuSE	9.0 and higher
	Mandriva (Mandrake)	9.0 and higher
UNIX	AIX	4.3 and higher
	FreeBSD	4.2 and higher
	Sun	Solaris 8 and higher
Novell	Netware	5.0 and higher
DOS		6.2 and higher

Browsers

Supported browsers for users that log into the KVM Over the NET™ switch include the following:

Browser	Version
IE	6 and higher
Firefox	1.5 and higher
Mozilla	1.7 and higher
Opera	9.0 and higher
Netscape	8.1 and higher

Note: See *Mac Systems*, page 130, for further information.

Components

Front View

KN9108:

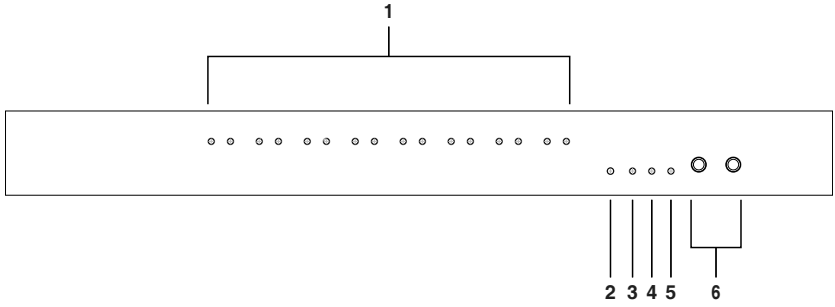

KN9116:

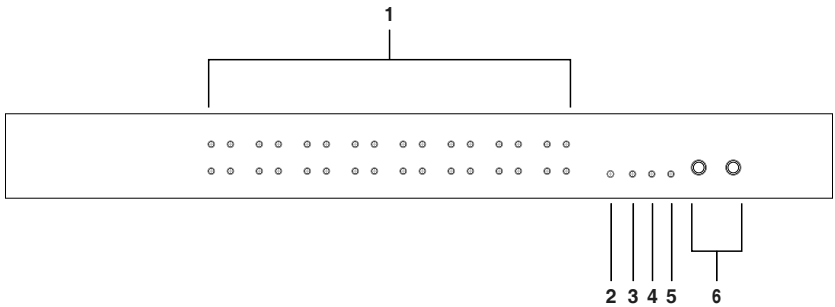

No.	Component	Description
1	Port LEDs	<p>The Port LEDs provide status information about their corresponding KVM Ports. There is one pair of LEDs for each Port. The one on the left is the <i>On Line</i> LED; the one on the right is the <i>Selected Port</i> LED:</p> <ul style="list-style-type: none">◆ An On Line LED lights GREEN to indicate that the computer attached to its corresponding port is up and running.◆ A Selected LED lights ORANGE to indicate that the computer attached to its corresponding port is the one that has the KVM focus. The LED is steady under normal conditions, but flashes when its port is accessed under Auto Scan Mode (see <i>Auto Scanning</i>, page 67).◆ When the KN9108 / KN9116 is first powered on, the On Line and Selected LEDs blink in sequence as the Switch performs a self-test.
2	Reset Switch	<p>Note: This switch is recessed and must be pushed with a thin object - such as the end of a paper clip, or a ballpoint pen.</p> <ul style="list-style-type: none">◆ Pressing and holding this switch in while powering on the KN9108 / KN9116 makes the switch use the factory installed firmware version rather than the firmware version that the switch has been upgraded to. This allows you to recover from a failed firmware upgrade and gives you the opportunity to try upgrading the firmware again.◆ Pressing and holding this switch in for more than two seconds performs a system reset.
3	Link LED	<p>Flashes GREEN to indicate that a Client program is accessing the device.</p>
4	10/100 Mbps Data LED	<ul style="list-style-type: none">◆ The LED lights ORANGE to indicate 10 Mbps data transmission speed.◆ The LED lights GREEN to indicate 100 Mbps data transmission speed.
5	Power LED	<p>Lights when the KN9108 / KN9116 is powered up and ready to operate.</p>
6	Port Switching Buttons	<ul style="list-style-type: none">◆ Press Port DOWN to switch from the current port to the previous port on the installation.◆ Press Port UP to switch from the current port to the next port on the installation.

Rear View

KN9108:

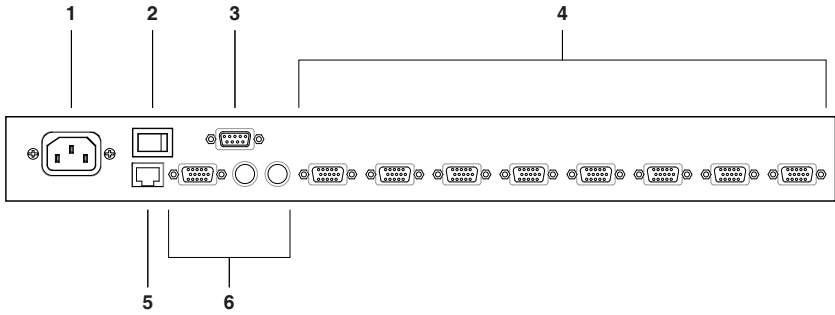

KN9116:

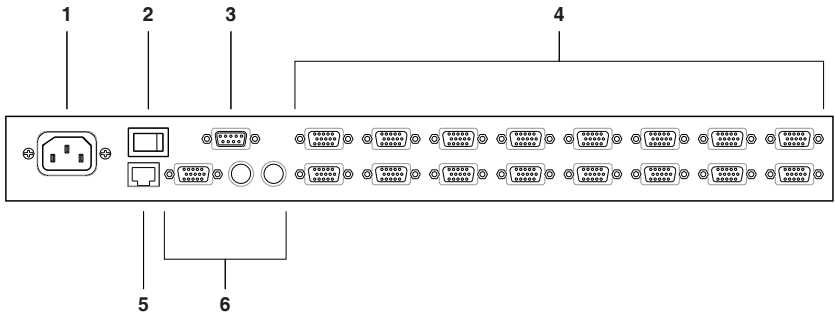

No.	Component	Description
1	Power Socket	The power cable plugs in here.
2	Power Switch	This standard rocker switch powers the unit on and off.
3	PON Port	This connector is provided for a Power over the Net™ (PON) unit to plug into. A PON device allows computers attached to the KN9108 / KN9116 to be booted remotely over a LAN, WAN or the Internet. Contact your dealer for more details.
4	KVM Ports (CPU Ports)	The cables that link the KN9108 / KN9116 to the computers plug in here. The shape of these connectors has been specifically modified so that only cables designed to work with this switch can plug in (see <i>Cables</i> , page 5).
5	LAN Port	The cable that connects the KN9108 / KN9116 to a LAN, WAN or the Internet plugs in here.
6	Local Console Section	The KN9108 / KN9116 can be accessed via a local console as well as over a LAN, WAN or the Internet. The cables for the local console (keyboard, monitor, and mouse) plug in here. Each port is color coded and marked with an appropriate icon to indicate itself.

Chapter 2

Hardware Setup

Before You Begin



1. Important safety information regarding the placement of this device is provided on page 123. Please review it before proceeding.
2. Make sure that power to all the devices you will be connecting up have been turned off. You must unplug the power cords of any computers that have the Keyboard Power On function.

Rack Mounting

The KN9108 / KN9116 can be mounted in a 1U system rack. For convenience and flexibility, the mounting brackets can screw into either the front or the back of the unit so that it can attach to the front or the back of the rack. Alternately, the front and rear modules can be separated so that the front module can be mounted at the front of the rack while the rear module is mounted at the rear. To rack mount the unit do the following:

1. Remove the four screws that attach the front and rear modules.
2. Using the screws provided with the rack mounting kit, screw the rack mounting brackets into the sides of the unit at the front and/or the rear, as shown in the diagrams below.
3. Slide the unit into the rack and secure it to the rack.

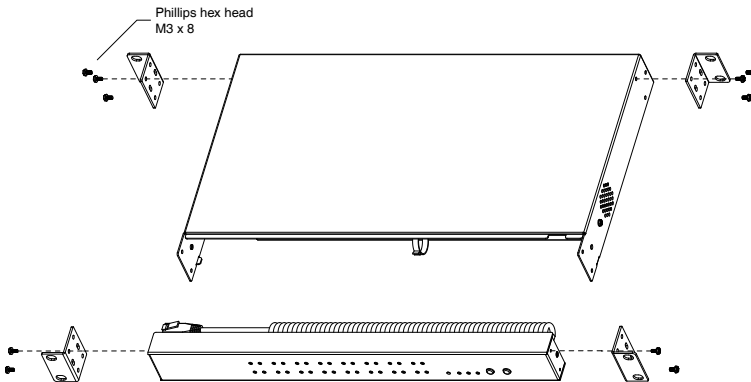
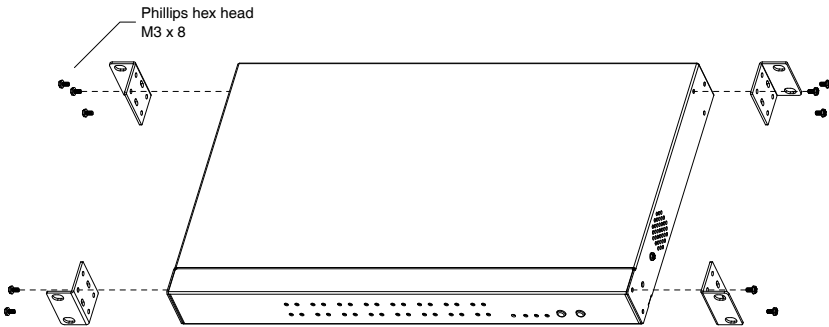

Installation

Installing your new KN9108 / KN9116 KVM Switch involves the following six steps (refer to the diagram below).

1. Plug your keyboard, mouse, and monitor into the unit's Console Ports.
2. Use KVM cable sets (see *Cables*, page 5), to connect any available CPU Port to the Keyboard, Video and Mouse ports of the computer you are installing.
3. Plug the LAN, WAN or Internet cable into the KN9108 / KN9116's RJ-45 socket.
4. Plug the female end of the power cord into the KN9108 / KN9116's Power Socket; plug the male end into an AC power source.
5. Turn on the power to the KN9108 / KN9116.
6. After the KN9108 / KN9116 is powered up, turn on the computers.

Note: Although the KN9116 is pictured in the diagram, the installation process is the same for the KN9108.

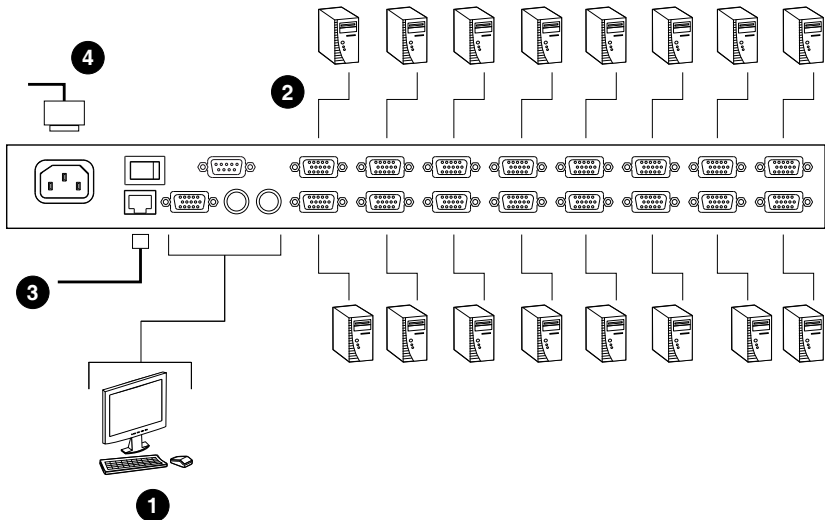

Hot Plugging

The KN9108 / KN9116 supports *hot plugging* - components can be removed and added back into the installation by unplugging and replugging their cables from the ports without the need to shut the unit down.

If you change computer positions, however, in order for the OSD menus to correspond to the CPU port changes, you must manually edit the Port Names for the OSD to reflect the new Port information. See *Port Names*, page 30, for details.

Note: If the computer's operating system does not support hot plugging, this function may not work properly.

Port ID Numbering

Each CPU port on the installation is assigned a unique Port ID. The Port ID is a two digit number which reflects the CPU Port on the KN9108 / KN9116 that the computer is connected to. Port numbers from 1 - 9 are padded with a preceding zero, so they become 01 - 09.

For example, a computer attached to **Port 6** would have a Port ID of: **06**.

Powering Off and Restarting

If it becomes necessary to power off the KN9108 / KN9116, or if the switch loses power and needs to be restarted, wait 10 seconds before powering it back on. The computers should not be affected by this, but if any of them should fail, simply restart the affected computers.

Port Selection

Port Selection is accomplished either by entering Hotkey combinations from the keyboard, or by means of the OSD (On Screen Display). *Hotkey Port Selection* is discussed in the next chapter; *OSD Operation* is discussed in detail in Chapter 6, and Chapter 6.

Chapter 3

Logging In

Overview

KN9108 / KN9116 switches can be accessed from a local console; an internet browser; a Windows application (AP) program; and a Java application (AP) program.

No matter which access method you choose, the switch's authentication procedure requires you to submit a valid username and password. If you supply an invalid login, the authentication routine will return an *Invalid Username or Password*, or *Login Failed* message. If you see this type of message, log in again with a correct username and password.

Local Console Login

After the local console has been connected and the KN9108 / KN9116 turned on, a login prompt appears on the console monitor:

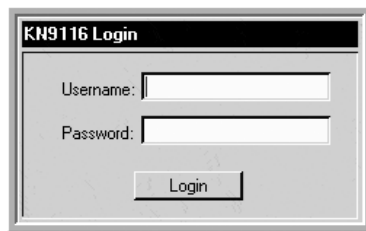

If this is the first time you are logging in, use the default Username: *administrator*; and the default Password: *password*. For security purposes, we strongly recommend that you use the User Management function (see page 36) to remove these and give yourself a unique Username and Password with the appropriate permissions.

Otherwise, simply key in your Username and Password, then click **Login** to bring up the Local Console OSD. The Local Console OSD is similar to the WinClient and Java Applet Viewer Main Pages. See *The User Interface*, page 63.

Browser Login

To log into the KN9108 / KN9116 from an Internet browser:

1. Open the browser and specify the IP address in the URL bar.

Note: For security purposes, a login string may have been set by the Administrator (See *Security*, page 47, for details). If so, you must include a forward slash and the login string along with the IP address when you log in. For example:

192.168.0.60/kn9116

Ask your Administrator for the IP address and login string.

2. When the Security Alert dialog box appears, accept the certificate – it can be trusted. (See *Trusted Certificates*, page 137, for details.)
3. A login page appears:

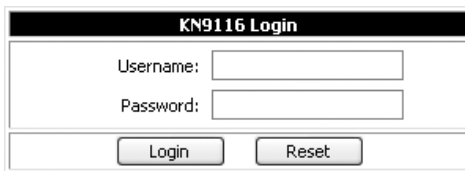

The image shows a web browser window displaying the 'KN9116 Login' page. The page has a black title bar with the text 'KN9116 Login' in white. Below the title bar, there is a white background with a thin border. Inside this area, there are two input fields: 'Username:' followed by a text box, and 'Password:' followed by a text box. Below the input fields, there are two buttons: 'Login' and 'Reset', both with a light gray background and a thin border.

4. Provide a valid Username and Password (set up by the KN9108 / KN9116 administrator), then Click **Login** to continue.

Note: 1. If you supply an invalid login, the authentication routine will return a message stating, *Invalid Username or Password. Please try again.* If you exceed the number of login failures set by the Administrator, a timeout period is invoked. You must wait until the timeout period expires before you can attempt to log in again (See *Login Failures*, page 49, for details).

2. If you are the Administrator and are logging in for the first time, use the default Username: *administrator*; and the default Password: *password*. For security purposes, we strongly recommend you remove these and give yourself a unique Username and Password (see *User Management*, page 36).
-

After you have successfully logged in, the KN9108 / KN9116 Main Web page appears with the *General* dialog box displayed. See Chapter 5, *Browser Operation* for full details.

WinClient AP Login

In some cases, the Administrator may not want the KN9108 / KN9116 to be available via browser access. AP versions of the WinClient and the Java Client are provided to enable direct access of the KN9108 / KN9116 without having to go through a browser.

The programs are initially downloaded from the browser page. After they have been downloaded by the Users, the Administrator can disable browser access (see *Working Mode*, page 49).

Installation

To install the WinClient AP on your computer, do the following:

1. Log into the KN9108 / KN9116 with your browser, and click the second *Windows Client* button (the one with the arrow). A screen similar to the one below appears:



2. Click **Save**. In the dialog box that comes up specify a location on your hard disk to save it to.

Starting Up

To connect to the KN9108 / KN9116, go to the location on your hard disk that you saved the WinClient AP program to, and double-click its icon (WinClient.exe) to bring up the WinClient AP Screen:

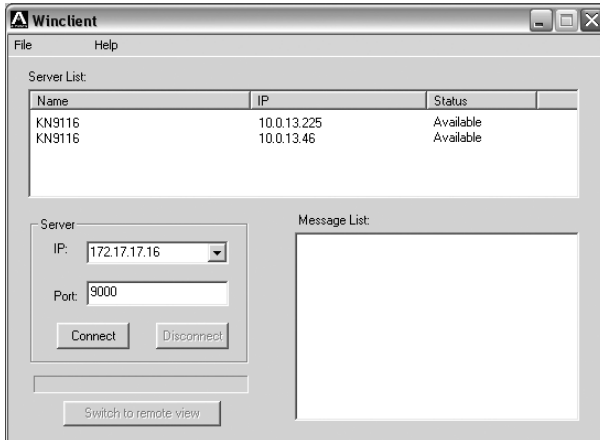

Note: You must have DirectX 8.0 or higher installed on your computer. If not, the Client program will not load.

The Connection Screen

A description of the Connection Screen is given in the following table

Item	Description
Menu Bar	<p>The Menu Bar contains two items: File and Help.</p> <ul style="list-style-type: none"> ◆ The <i>File Menu</i> allows the operator to Create, Save, and Open user created Work files (see page 20 for details). ◆ The <i>Help Menu</i> displays the WinClient AP version.
Server List	<p>Each time the WinClient.exe file is run, it searches the User's local LAN segment for KN9108 / KN9116 units, and lists whichever ones it finds in this box. If you want to connect to one of these units, double-click it.</p>
Server	<p>This area is used when you want to connect to a KN9108 / KN9116 at a remote location. You can drop down the <i>IP</i> list box and select an address from the list. If the address you want isn't listed, you can key in the IP address you want. Then, key in the Port number in the <i>Port</i> field. If you don't know the Port number, then contact the Administrator.</p> <p>When the IP address and Port number for the unit you wish to connect to have been specified, Click Connect to start the connection. When you have finished with your session, Click Disconnect to end the connection.</p>
Message List	<p>Lists status messages regarding the connection to the KN9108 / KN9116.</p>
Switch to Remote View	<p>Once contact with a KN9108 / KN9116 has been established, this button becomes active. Click it to switch to the main page (see <i>The User Interface</i>, page 63, for full details) and take over console control of the unit that is attached to the KN9108 / KN9116.</p> <p>The screen output of the unit appears on your monitor. Your keystrokes and mouse movements are captured and sent to the KN9108 / KN9116 to be executed on the attached unit.</p> <p>If the KN9108 / KN9116 is connected to a KVM switch, you can control the switch and the computers connected to it just as if you were connected locally.</p>

■ The File Menu

The *File Menu* allows the operator to Create, Save, and Open user created Work files. A Work File consists of all the information specified in a Client session. This includes the Server List and Server IP list items, as well as the Hotkey settings.

Whenever a user runs the Client program, it opens with the values contained in the *current work file*. The current work file consists of the values that were in effect the last time the program was closed.

The File menu consists of three items, as follows:

New	Allows the user to create a named work file so its values will not be lost, and it will be available for future recall.
Open	Allows the user to open a previously saved work file and use the values contained in it.
Save	Allows the user to save the values presently in effect as the <i>current work file</i> .
Exit	Exits the WinClient AP.

Connecting

To connect to a KN9108 / KN9116 unit:

1. From the *Server List* box, **double-click** the device that you wish to connect to. Or, specify the IP address and port number in the *Server IP* and *Port* input boxes, and then Click **Connect**. The *Login* dialog box appears:

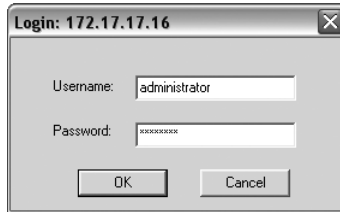

2. Key in a valid Username and Password, and then click **OK**.
The program attempts to connect to the selected KN9108 / KN9116 unit. While it does so, you can check the *Message List* window for status messages regarding the operation's progress.
3. Once contact with the KN9108 / KN9116 has been established, the *Switch to Remote View* button becomes active. Click it to connect to the KN9108 / KN9116 and take over console control of the unit that is connected to it.

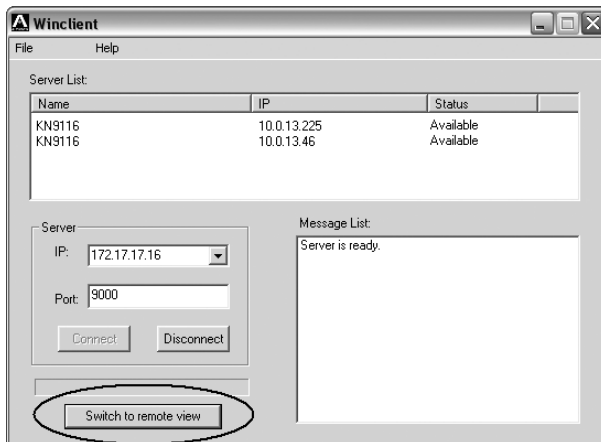

Operation

Once a connection to the KN9108 / KN9116 has been established, the remote system's video output is captured and displayed on your monitor. At the same time, your local keystroke and mouse input is captured and sent to the remote system.

The look and feel of the WinClient AP Control Panel operation is the same as for the browser version of the WinClient ActiveX Viewer. Refer to *The User Interface*, page 63, for details.

Java Client AP Login

Installation

To install the Java Client on your computer, do the following:

1. Log into the KN9108 / KN9116 with your browser, and click the second *Java Client* button (the one with the arrow). A screen similar to the one below appears:

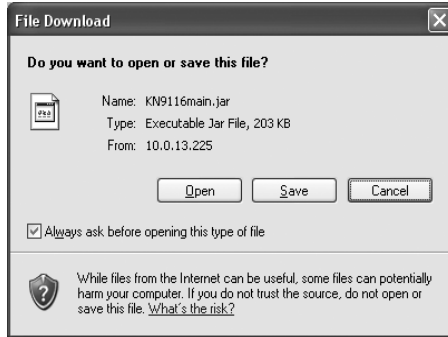

2. Click **Save**. In the dialog box that comes up specify a location on your hard disk to save it to.

Starting Up

To connect to the KN9108 / KN9116 do the following:

1. Go to the location on your hard disk that you downloaded the Java Client AP program to, and double-click its icon (JavaClient.jar) to bring up the *Address Input* dialog box:



(Continues on next page.)

2. Key in the IP address for the unit you want to connect to – including a forward slash followed by the login string (set by the administrator).

Note: 1. If the system administrator set the switch's *Program* port to something other than the default you must specify the port number along with the IP address. For example:

192.168.0.132:9111

2. For security purposes, a login string may have been set by the Administrator (See *Security*, page 47, for details). If so, you must include a forward slash and the login string along with the IP address when you log in. For example:

192.168.0.132:9111/kn9116

Ask your Administrator for the IP address and login string.

After you establish a connection, a Login dialog box appears:

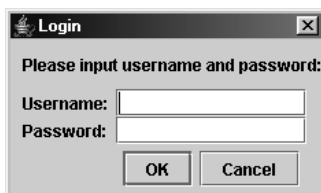

3. Provide a valid Username and Password, and then click **OK**.

Once the authentication procedure completes successfully, the KN9108 / KN9116 main page displays on your monitor.

Operation

The look and feel of the AP Java client operation is the same as for the browser version of the Java Applet Viewer. Refer to *The User Interface*, page 63 for details.

Chapter 4

Administration

Overview

This chapter explains the administrative procedures that let the Administrator (and users with administration permission - see *User Management*, page 36) configure and control the overall operations of the KN9108 / KN9116, as well as how to operate the KN9108 / KN9116 from the local console. The *Administration* tab is disabled (grayed out) for users who do not have administration permission.

The Local Console

Once the KN9108 / KN9116 has been installed, the next step that the Administrator needs to perform is to set up the unit for user operation. The most convenient way to do this for the first time is from the local console. See *Local Console Login*, page 15.

After you successfully log in, the Local Console OSD appears:

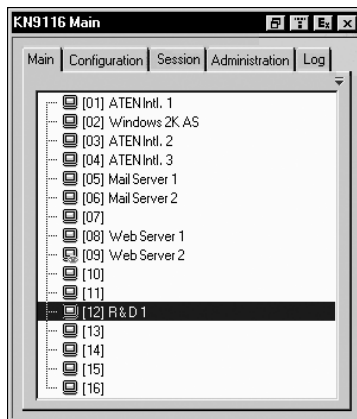

There are four buttons on the title bar at the top right. They are described below starting from the left and moving to the right:

- ◆ **Screen View:** clicking this button (or pressing F6) toggles the display between full screen and window view.

- ◆ **Transparent:** clicking this button (or pressing F7) causes the OSD display to become semi-transparent, allowing whatever the OSD screen is covering to show through. Clicking the button again causes the OSD display to revert back to normal opacity.

Note: 1. The *Screen View* and *Transparent* buttons are on the Local Console OSD only. The Web browser OSD and AP versions do not have these functions.

2. It is recommend that you set the refresh rate of the monitor higher than 75Hz before using this feature.
3. When the transparent feature is enabled, if you switch to a null port the feature will be disabled.

-
- ◆ **Log out:** clicking this button (or pressing F8) closes the OSD display and logs you out of the session.
 - ◆ **Close:** clicking this button (or pressing Esc) closes the OSD display but does not log you out of the session. You can bring the display back with the OSD hotkeys (see *OSD Hotkey*, page 95).

The OSD consists of four pages, each with a specific set of functions: Main, Configuration, Administration, and Log.

The Main Page

The Main page governs port access. Selecting a port and double-clicking it switches you to the device on that port.

- ♦ A *monitor* icon is in front of the port number. The monitor icon is green for ports that have devices connected to them that are powered on; otherwise, it is gray.
- ♦ If a port has been specified as a Quick View port (see below), an *eye* icon is displayed along with the monitor icon to indicate so.

In addition to using this page to select ports to switch to, the administrator can also use this page to enable/disable Quick View status for selected ports, and to create, modify, or delete names for each of the ports. The following sections describe how to enable Quick View and how to assign names to ports.

Quick View Ports

Selecting certain ports as Quick View ports is a way of limiting which ports are included when the KN9108 / KN9116 is in Auto Scan mode. If the KN9108 / KN9116 is configured to only auto scan ports that have Quick View status (see *Scan Select*, page 95), designating a port as a Quick View port in this dialog box means that it will be included when auto scanning is in effect.

The spacebar toggles a port's Quick View status. To select/deselect a port, highlight it and press the **spacebar**. When a port has been selected as a Quick View port, an *eye* icon displays in the port icon column to indicate so. When a port isn't selected, there are no *eye* icons in the column.

The List Function

The List Function lets you broaden or narrow the scope of which ports the OSD displays (lists) in the Main Screen. To invoke the List Function, click the arrow at the upper right corner of the screen, or press **[F3]**:

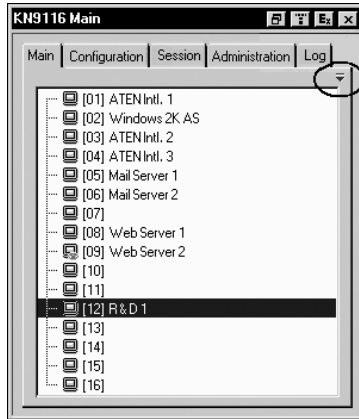

The screen changes to allow you to choose the ports that will be listed:

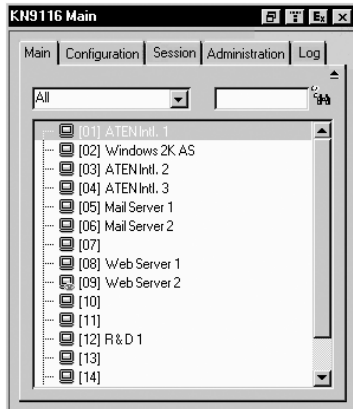

- ◆ The drop down list on the left offers four fixed choices as shown in the table below:

Choice	Meaning
All	Lists all of the ports on the installation.
Powered On	Lists only the ports that have their attached devices powered on.
Quick View	Lists only the ports that have been selected as Quick View ports (see <i>Quick View Ports</i> , page 27)
Quick View + Powered On	Lists only the ports that have been selected as Quick View Ports (see <i>Quick View Ports</i> , page 27), and that have their attached computers Powered On.

- ◆ The text input box on the right allows you to key in a port name so that only port names that match what you key in show up in the List. Wildcards (? and *) are acceptable, so that more than one port can show up in the list. For example, if you key in **Web***, both Web Server 1 and Web Server 2 would show up in the list, as shown in the screen shot below:

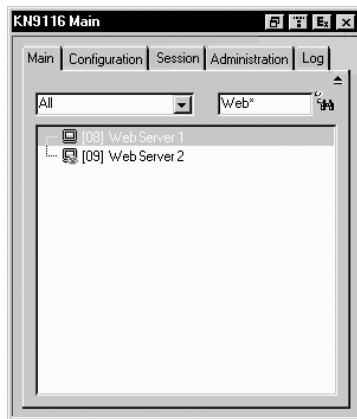

- ◆ After you key in your string, either click the binoculars icons to the right of the box, or press **[Enter]**.
- ◆ To go back to the default view, erase the string and either click the binoculars to the right of the box, or press **[Enter]**.
- ◆ To dismiss the List function, click the arrow or press **[F3]**.

Port Names

To help remember which computer is attached to a particular port, every port can be given a name. This field allows the Administrator to create, modify, or delete port names. To configure a port name:

1. Click once on the port you want to edit, wait one second and then click again. (Alternately, use the up and down arrow keys to move the highlight bar to the port, and then press the F2 function key.)

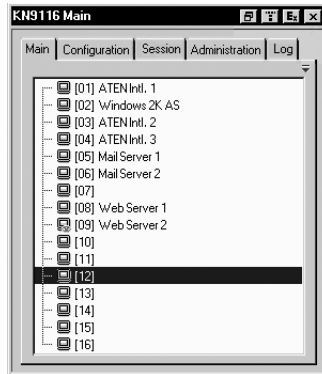

Note: This is not a double-click. It involves two separate clicks. A double-click will switch you to the device attached to the port.

After a second or two, the bar changes to provide you with a text input box:

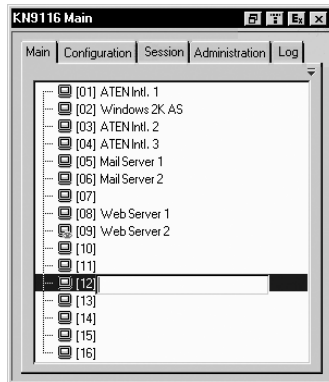

2. Key in the new Port Name, or modify/delete the old one.

The maximum number of characters allowed for a Port Name is 19. You can use all letters, numbers, and symbols on the typewriter keys of keyboards with PC US English layout.

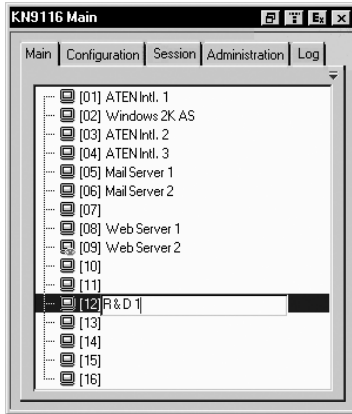

3. When you have finished editing the port name, click anywhere outside of the input box to complete the operation.

Port Operation

Since port operation is the same as for the Windows and Java Client OSDs, the procedures are discussed in Chapter 6 and Chapter 6.

When accessing servers in the switch from the local console, if you invoke the OSD while in the port you can press the F6 function key to hide the background and enlarge the OSD box. Press [F6] again to show the background.

The Configuration Page

The OSD *Configuration* page allows users to set up their own, individual, working environments. The KN9108 / KN9116 stores a separate configuration record for each user profile, and sets up the working configuration according to the *Username* that is used to log in.

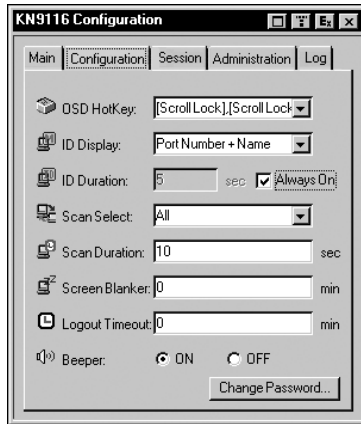

(Continues on next page.)

(Continued from previous page.)

The Configuration page settings are explained in the following table:

Setting	Function
OSD Hotkey	Selects which Hotkey controls the OSD function: [Scroll Lock] [Scroll Lock] or [Ctrl] [Ctrl] . Since the Ctrl key combination may conflict with programs running on the computers, the default is the Scroll Lock combination (see <i>Hotkey Operation</i> , page 67).
ID Display	Selects how the Port ID is displayed: the Port Number alone (PORT NUMBER); the Port Name alone (PORT NAME); or the Port Number plus the Port Name (PORT NUMBER + PORT NAME). The default is PORT NUMBER + PORT NAME.
ID Duration	Determines how long a Port ID displays on the monitor after a port change has taken place. You can choose an amount from 0–255 seconds, or enable <i>Always On</i> for the Port ID to be always displayed. The default is 5 Seconds. 0 is Always Off.
Scan Select	Selects which computers will be accessed under Auto Scan Mode (see <i>Auto Scanning</i> , page 67). Choices are: ALL – All the Ports which have been set Accessible (see <i>Port Access</i> , page 38); POWERED ON – Only those Ports which have been set Accessible and are Powered On; QUICK VIEW – Only those Ports which have been set Accessible and have been selected as Quick View Ports (see <i>Quick View Ports</i> , page 27); QUICK VIEW + POWERED ON – Only those Ports which have been set Accessible and have been selected as Quick View Ports and are Powered On. The default is ALL.
Scan Duration	Determines how long the focus dwells on each port as it cycles through the selected ports in Auto Scan Mode (see <i>Auto Scanning</i> , page 67). Key in a value from 0–255 seconds. The default is 10 seconds; a setting of 0 disables the Scan function.
Screen Blanker	If there is no input from the console for the amount of time set with this function, the screen is blanked. Key in a value from 1–30 minutes. A setting of 0 disables this function. The default is 0 (disabled).
Logout Timeout	If there is no Operator input for the amount of time set with this function, the Operator is automatically logged out. A login is necessary before the KN9108 / KN9116 can be accessed again. Enter a value from 0–180 minutes. The default is 30 minutes. 0 disables the function.
Beeper	When set to ON , the beeper sounds whenever the port is switched, when activating the Auto Scan function (see <i>Auto Scanning</i> , page 67), or when an invalid entry is made on an OSD menu. The default is ON.
Change Password	Allows a user to change the account password. After clicking the Change Password button, a dialog box appears. Enter the old password. Then, enter a new password and confirm it by entering it again. Press OK to save changes, or press Cancel to discard changes.

The Session Page

The *Session* page lets the administrator see at a glance all the users currently logged into the KN9108 / KN9116, and provides their IP address.

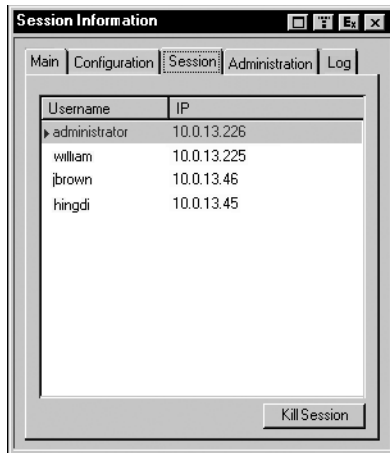

This page gives the administrator the option of forcing a user logout by selecting the user and clicking **Kill Session**.

The arrow at the left of the Username indicates the currently active administrator (i.e. you). Select another user by clicking on the Username to move the highlight bar (the arrow does not move) before clicking **Kill Session**.

Note: The Session page only appears in Administrator sessions. It is not available for ordinary users.

The Administration Page

When you click the Administration tab, the Administration page comes up. Each of the administrative functions is represented by an icon at the left of the page. Clicking the icon brings up its associated dialog box. When the Administration page first comes up the *General* dialog box appears:

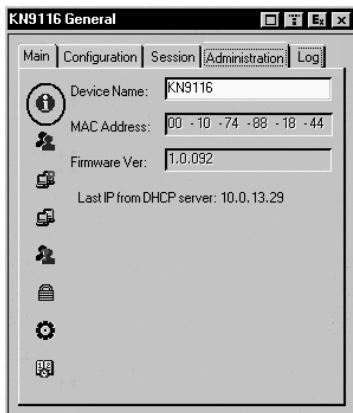

General

The General Page presents four items of information. This is the same information that displays after you log in from a browser, or when you click the *General* icon at the top left of the browser main page. The meaning of these items is described in the table below.

Item	Description
Device Name	This field lets you give the switch a unique name. This can be convenient when you need to differentiate among several devices in multi-station installations.
MAC Address	This item displays the KN9108 / KN9116's MAC address.
Firmware Ver	This item displays the current firmware version number. You can reference it to see if there are newer versions available on the Altusen website.
Last IP from DHCP Server	If the switch is on a network that uses DHCP assigned IP addresses, this item is a convenient way of ascertaining what its IP address is, to inform the Users which IP to use when logging in.

User Management

The User Management dialog box is used to create, delete and manage user profiles. Up to 64 user profiles can be established.

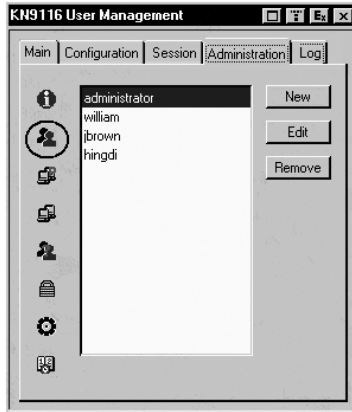

- ◆ To delete a user profile, select it in the list box, and Click **Remove**.
- ◆ To modify a user profile, select it and Click **Edit**.
- ◆ To add a user, Click **New**.

If you choose *Edit* or *New*, a dialog box similar to the one below appears:

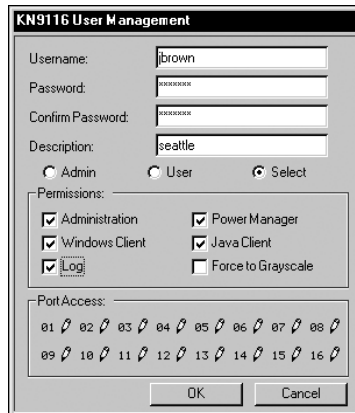

Fill in the required information for a new User profile, or modify the existing information to edit a previous profile. A description of the field headings is given in the table below:

Heading	Description
Username	A minimum of 6 and a maximum of 15 characters is allowed.
Password	A minimum of 8 and a maximum of 15 characters is allowed.
Confirm Password	To be sure there is no mistake in the password you are asked to enter it again. The two entries must match.
Description	Additional information about the user that you may wish to include. (optional)
Admin	Gives the user Administrator level access to the KN9108 / KN9116. All permissions are granted (see below).
User	Gives the user User level access to the KN9108 / KN9116. WinClient ActiveX Viewer, Power Manager, and Java Client permissions are granted (see below).
Select	If the permissions selected for the account do not match those specified for Administrators or Users, Select is automatically chosen as the account type.
Permissions	<ol style="list-style-type: none"> 1. Checking <i>Administration</i> assigns administrative privileges to the account, which allows the user to modify the KN9108 / KN9116's Administration page settings. 2. Checking <i>Windows Client</i> allows the user to access the KN9108 / KN9116 via the WinClient ActiveX Viewer software. 3. Checking <i>Log</i> causes the Log Server and Log buttons to appear on the Main web page when the user logs in and allows the user to access these features. 4. Checking <i>Power Manager</i> causes the PON button to appear on the Main web page when the user logs in and allows the user to access attached Power over the Net™ devices. 5. Checking <i>Java Client</i> allows the user to access the KN9108 / KN9116 via the Java Client software. 6. Checking <i>Force to Grayscale</i> changes the remote display for all users to grayscale. This can speed up I/O transfer in low bandwidth situations. The default setting is disabled (unchecked).

Heading	Description
Port Access	<p>This function allows the Administrator or a User with <i>Administration</i> permission to define the selected User's access to the computers on a Port-by-Port basis.</p> <p>For each User profile, select a port and click it to cycle through the choices:</p> <p>Full - The user can view the screen and can perform operations on the system from the keyboard and mouse.</p> <p>View - A diagonal line through the port icon indicates the port access is View. The user can view the screen, but cannot perform operations on the system.</p> <p>Null (no access rights) - An X through the port icon indicates no port access. The Port will not show up on the User's list on the Main Screen.</p> <p>Repeat until access rights have been set for all ports.</p> <p>The default is Full for all users on all Ports.</p>

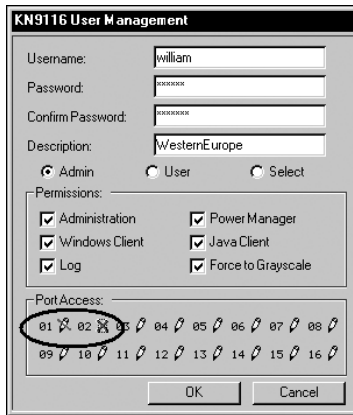

Service Configuration

The Service Configuration dialog is composed of two main panels: Access Port and Log Server:

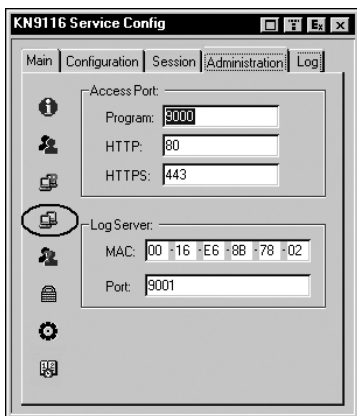

Access Port

As a security measure, if a firewall is being used, the Administrator can specify the port numbers that the firewall will allow, and set the firewall accordingly. Users must specify the port number when they log in to the KN9108 / KN9116. If an invalid port number (or no port number) is specified, the KN9108 / KN9116 will not be found.

-
- Note:** 1. If there is no firewall (on an Intranet, for example), it doesn't matter what these numbers are set to, since they have no effect.
2. You must set different values for each of the service ports.
-

An explanation of the fields is given in the table below:

Field	Explanation
Program	This is the port number that must be specified when connecting from the WinClient ActiveX Viewer and Java Client software program. Valid entries are from 1024 - 60,000. The default is 9000.
HTTP	The port number for a browser login. The default is 80.
HTTPS	The port number for a secure browser login. The default is 443.

Log Server

Important transactions that occur on the KN9108 / KN9116, such as logins and internal status messages, are kept in an automatically generated log file. In this panel, you specify the MAC address and a port number for the computer that the Log Server resides on.

Installation and operation of the Log Server is discussed in Chapter 8. The Log File is discussed on page 97.

Network

The Network dialog is used to specify the KN9108 / KN9116's network environment. The box is divided into two panels: IP Address and DNS Server.

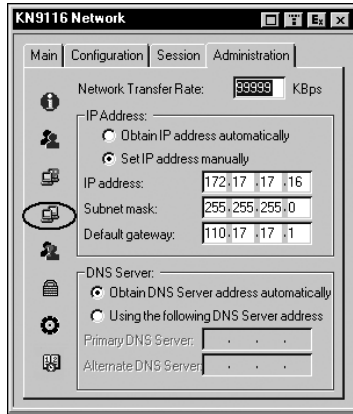

Network Transfer Rate

This setting allows you to tailor the size of the data transfer stream to match network traffic conditions by setting the rate at which the KN9108 / KN9116 transfers data between the switch and the client computers. The range is from 4–99999 Kilobytes per second (KBps).

IP Address

The KN9108 / KN9116 can either have its IP address assigned dynamically (DHCP), or it can be given a fixed IP address.

- ◆ For dynamic IP address assignment, select the *Obtain IP address automatically* radio button.
- ◆ To specify a fixed IP address, select the *Set IP address manually* radio button and fill in the IP address, subnet mask and default gateway.

DNS Server

You can set the KN9108 / KN9116 to automatically obtain the DNS server address, or you can specify the primary and alternate DNS servers' addresses.

- ◆ To automatically obtain the DNS server address, select the *Obtain DNS Server address automatically* radio button.
- ◆ To specify the address of the DNS server, select the *Use the following DNS Server address* radio button and fill in the addresses for the primary DNS server (mandatory) and alternate DNS server (optional).

ANMS

The Advanced Network Management Settings page is used to set up login authentication and authorization management from external sources. Click on the ANMS icon to select RADIUS, LDAP, or CC Management.

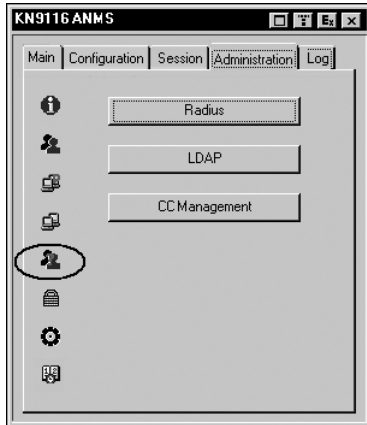

RADIUS

If you are using a RADIUS server, set up its parameters as follows:

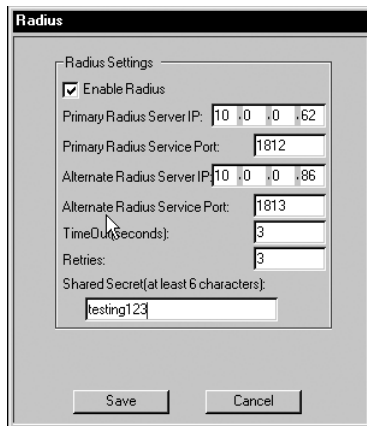

1. Check Enable.
2. Fill in the IP addresses and Service Ports for the Primary and Alternate RADIUS servers.

(Continues on next page.)

(Continued from previous page.)

3. Set the time in seconds that the KN9108 / KN9116 waits for a RADIUS server reply before it times out in the Timeout field.
4. Set the number of RADIUS retries allowed in the Retries field.
5. Key the *Shared Security* character string for authentication between the KN9108 / KN9116 and the RADIUS Server in this field.
6. On the RADIUS server, set the access rights for each user according to the information in the table on page 44.

Note: 1. The characters are not case sensitive. Capitals or lower case work equally well.

2. Characters are comma delimited.

3. An invalid character in the configuration string will prohibit access to the KN9108 / KN9116 for the user.

Examples:

String	Meaning
c,w,p	User has administrator privileges; user can access the system via the WinClient ActiveX Viewer; user can access the attached PN0108.
w,j,l	User can access the system via the WinClient ActiveX Viewer; user can access the system via the Java Client; user can access log information via the user's browser.

Character	Meaning
C	Grants the user administrator privileges, allowing the user to configure the system.
W	Allows the user to access the system via the WinClient ActiveX Viewer program.
J	Allows the user to access the system via the Java Client program.
P	Allows the user to access an attached Power Over the Net™ device.
L	Allows the user to access log information via the user's browser.
PN	Restricts the user from accessing the OSD port list. Syntax: pn/1/2/3/4
PV	Limits the user's access to viewing of the OSD port list only. Syntax: pv/1/2/3/4
UHK	Defines the OSD Hotkey (see <i>OSD Hotkey</i> , page 95).. (uhk0: Scroll Lock + Scroll Lock; uhk1: Ctrl + Ctrl) Syntax: uhk0
UOL	Defines the OSD List Function (see page 28). (uol0: All; uol1: Powered On; uol2: Quick View; uol3: Quick View + Powered On) Syntax: uol0
UODM	Selects how the Port ID displays (see <i>ID Display</i> , page 95). (uodm0: Port Number + Port Name; uodm1: Port Number; uodm2: Port Name) Syntax: uodm0
UODT	Determines the length of time in seconds that the Port ID displays on the monitor after a port change (see <i>ID Duration</i> , page 95). Syntax: uodtn (where <i>n</i> represents a number from 0-255)
UBUZ	Turns the beeper on or off (see <i>Beeper</i> , page 95). (ubuz0: Beeper Off; ubuz1: Beeper On) Syntax: ubuz0
ULT	When there is no input from the user for the amount of time set with this function, the user is automatically logged out. The user will need to log in again. Set the Logout Timeout from 0-180 minutes. Syntax: ultn (where <i>n</i> represents a number from 0-180)
USM	Selects which computers are accessed under Auto Scan Mode (see <i>Scan Select</i> , page 95). (usm0: All; usm1: Powered On; usm2: Quick View; usm3: Quick View + Powered On) Syntax: usm0
UST	Determines the length of time in seconds the KVM focus dwells on each port in Auto Scan Mode (see <i>Scan Duration</i> , page 95). Syntax: ustn (where <i>n</i> represents a number from 0-255)

LDAP / LDAPS

To allow authentication and authorization for the KN9108 / KN9116 via LDAP / LDAPS, set the parameters as follows:

1. Check the box to enable LDAP / LDAPS authentication and authorization.
2. Click a radio button to specify whether to use LDAP or LDAPS
3. Fill in the IP address and port number for the LDAP or LDAPS server. For LDAP, the default port number is 389; for LDAPS, the default port number is 636.
4. Set the time in seconds that the KN9108 / KN9116 waits for an LDAP or LDAPS server reply before it times out.
5. Consult the LDAP / LDAPS administrator to ascertain the appropriate entry for this field. For example, the entry might look like this:
ou=kn4132,dc=aten,dc=com
6. Key in the LDAP administrator's username.
7. Key in the LDAP administrator's password.
8. Set the distinguished name of the search base. This is the domain name where the search starts for user names.

Note: If *LDAP Settings* is enabled, the LDAP schema for MS Active Directory must be extended. See *LDAP Server Configuration*, page 107, for details.

CC Management Settings

To allow authorization for the KN9108 / KN9116 through a CC (Control Center) server, check *Enable* and fill in the CC Server's IP address and the port that it listens on in the appropriate fields.

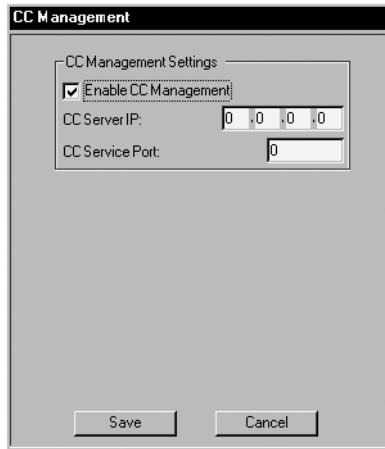

Note: The current firmware (insert firmware version) supports CC1000 only. Future firmware upgrades will provide support for CC2000. Please visit our website to download the most up-to-date version of the firmware.

Security

The Security page controls access to the KN9108 / KN9116.

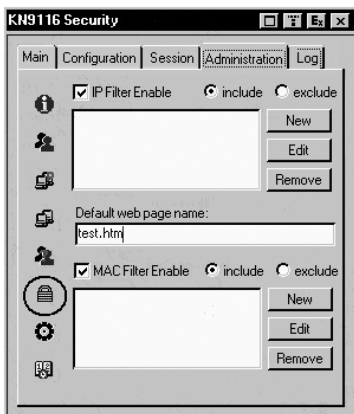

- ♦ The *Default web page name* lets the Administrator specify a login string (in addition to the IP address) that the user must include when accessing the KN9108 / KN9116 with a browser or the Java Client AP. For example:
`192.168.0.126/abcdefg`
- ♦ The user must include the forward slash and the string along with the IP address. For security purposes, we recommend that you change this string from time to time.

(Continues on next page.)

(Continued from previous page.)

- ◆ *IP* and *MAC Filters* control access to the KN9108 / KN9116 based on the *IP* and/or *MAC* addresses of the computers attempting to connect. A maximum of 100 *IP* filters and 100 *MAC* filters are allowed. To enable *IP* and/or *MAC* filtering, **Click** to put a check mark in the *IP Filter Enable* and/or *MAC Filter Enable* checkbox.
- ◆ If the include button is checked, all the addresses within the filter range are allowed access to the KN9108 / KN9116; all other addresses are denied access.
- ◆ If the exclude button is checked, all the addresses within the filter range are denied access to the KN9108 / KN9116; all other addresses are allowed access.
- ◆ To add a filter, Click **New**. A dialog box similar to one of the ones below appears:

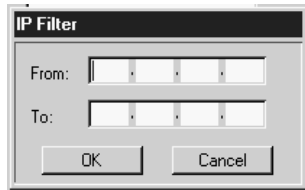

The IP Filter dialog box has a title bar labeled "IP Filter". It contains two rows of input fields. The first row is labeled "From:" and the second row is labeled "To:". Each row has a single text input field. Below the input fields are two buttons: "OK" and "Cancel".

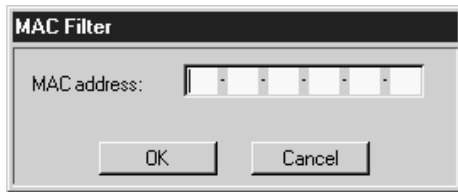

The MAC Filter dialog box has a title bar labeled "MAC Filter". It contains a single row of input fields labeled "MAC address:". The input field is a single text box. Below the input field are two buttons: "OK" and "Cancel".

Note: Each *IP* filter can consist of a single address, or a range of addresses. To filter a single *IP* address, key in the same address in both the *From* and *To* fields. To filter a continuous range of *IP* addresses, key in the start of the range in the *From* field; key in the end of the range in the *To* field.

After you specify the filter addresses, Click **OK**.

- ◆ To delete a filter, select it and Click **Remove**.
- ◆ To modify a filter, select it and Click **Edit**. The *Edit* dialog box is similar to the *New* dialog box. When it comes up, simply delete the old address and replace it with the new one.

Customization

The Customization dialog box is arranged in four major sections:

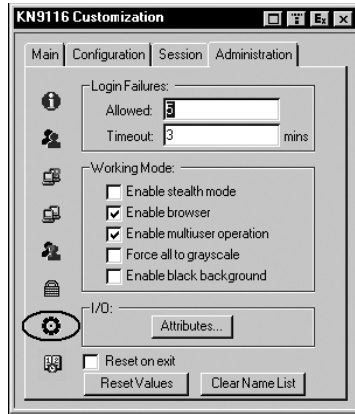

Login Failures

- ◆ **Allowed:** sets the number of consecutive failed login attempts that are permitted from a remote computer.
- ◆ **Timeout:** sets the amount of time a remote computer must wait before attempting to login again after it has exceeded the number of allowed failures.

Working Mode

- ◆ If *Stealth Mode* is **enabled**, the KN9108 / KN9116 refuses ICMP "echo request" packets.
- ◆ To permit browser access to the KN9108 / KN9116, click to put a check mark in the *Enable Browser* checkbox. If browser access is not enabled, users will not be able to log into the unit via their browsers.
- ◆ To permit multiple users to simultaneously access the KN9108 / KN9116, check *Enable multiuser operation*.
- ◆ If *Force all the grayscale* is enabled, the remote displays of all devices connected to the KN9108 / KN9116 are changed to grayscale. This can speed up I/O transfer in low bandwidth situations.
- ◆ If *Enable black background* is checked, the remote OSD displays on a black background.

I/O

Attributes

Attributes allows you to set attribute parameters for each of the ports.

To change the port attribute:

1. Click **Attributes...** on the *Customization* dialog box. The *Setting I/O Attributes* dialog box appears. The port numbers are listed in the column on the left. The port's attributes are shown to its right.
2. Double-click on a port entry. The *I/O attributes* dialog box appears:

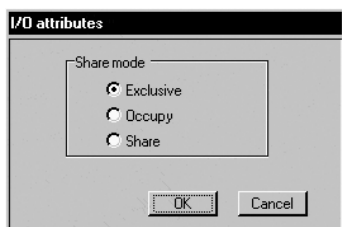

3. Select a *Share Mode* attribute for the port (see the table below)

Attribute	Definition
Exclusive	The first user to switch to the port has exclusive control over the port. No other users can view the port. The <i>Timeout</i> function does not apply to ports which have this setting.
Occupy	The first user to switch to the port has control over the port. However, up to 32 users may view the video from the port. If the user who controls the port is inactive for longer than the time set in the <i>Timeout</i> box, port control is transferred to the next user to move the mouse or strike the keyboard.
Share	Up to 32 users simultaneously share control over the port. Input from the users is placed in a queue and executed chronologically. Users should take advantage of the Message Board feature, which allows a user to take control of the keyboard and mouse or keyboard, mouse, and video of a Share port (see <i>The Message Board</i> , page 86).

4. Click **OK**. (To exit without saving your changes, click **Cancel**.) The dialog box closes.
5. On the *Setting I/O Attributes* dialog box click **Apply** to keep your changes. (To exit without saving your changes, click **Cancel**.)

Timeout

The Timeout setting applies to ports with the *Occupy I/O* attribute. It controls the amount of time (0-255 seconds) that elapses before an inactive user is timed out when other users are waiting to take control of the port. Once the first user becomes inactive (i.e. stops sending keyboard and mouse input), it begins to countdown the amount of time specified in the Timeout field. If the user does not send input before the time expires, that user is timed out and the port is released. The next user to send mouse or keyboard input gains control of the port.

To apply Timeout settings:

1. Click **Attributes...** on the *Customization* dialog box. The *Setting I/O Attributes* dialog box appears (see *Attributes*, page 50).
2. In the Timeout field, enter the Timeout time in seconds.
3. Click Apply. (To exit without saving your changes, click **Cancel**.)

Note: The Timeout setting applies to all ports on the KN9108 / KN9116.

Miscellaneous

The functions performed by the remaining elements at the bottom of the screen are described in the table below:

Item	Description
Reset on exit	Placing a check here causes the KN9108 / KN9116 to reset itself and implement all the new changes when you log out. Following the reset, wait approximately 30 to 60 seconds before logging back in. For example, if you change the IP address in the Network dialog box, you must open this page and enable <i>Reset on exit</i> before logging out. Otherwise, the change will not take effect.
Reset Values	Clicking this button undoes all changes that have been made to the Configuration and Administration pages (except for port names, usernames, and passwords) and returns the parameters to the original factory default settings (see <i>OSD Factory Default Settings</i> , page 136).
Clear Name List	This function clears the Port Names on the Main page.

Date/Time

Note: Only the Local Console OSD has the Date/Time function. The Web browser versions do not.

The Date/Time dialog box lets the Administrator set up the KN9108 / KN9116's time parameters:

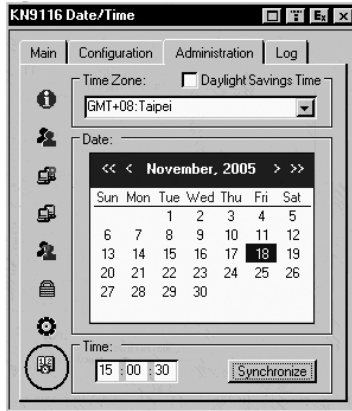

- ◆ If your country or region employs Daylight Saving Time (Summer Time), check the corresponding box.
- ◆ To establish the time zone that the KN9108 / KN9116 is located in, drop down the *Time Zone* list and choose the city that most closely corresponds to where it is at.
- ◆ To set the year and day, use the Calendar graphic.
 - ◆ Clicking << or >> moves you backward or forward by one year increments.
 - ◆ Clicking < or > moves you backward or forward by one month increments.
 - ◆ In the calendar, click on the day.
- ◆ To set the time, use the 24 hour HH:MM:SS format.
- ◆ Click **Synchronize** to save your settings.

The Log Page

Note: Only the Local Console OSD has the Log tab. The Web browser and AP versions do not. However, the log can be access through the browser via the *Log* icon. See *Web Page Icons*, page 57.

Clicking the Log tab brings up the contents of the log file. The log file is discussed in Chapter 7, *The Log File*, page 97.

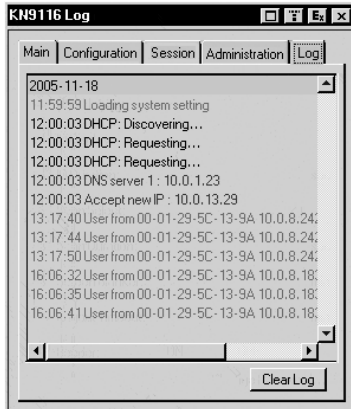

Chapter 5

Browser Operation

Overview

After you have successfully logged in (see *Logging In*, page 15), the KN9108 / KN9116 Main Web page appears. All of the features are described in the sections that follow.

Main Web Page

The Main Web page appears with the *General* dialog box displayed:

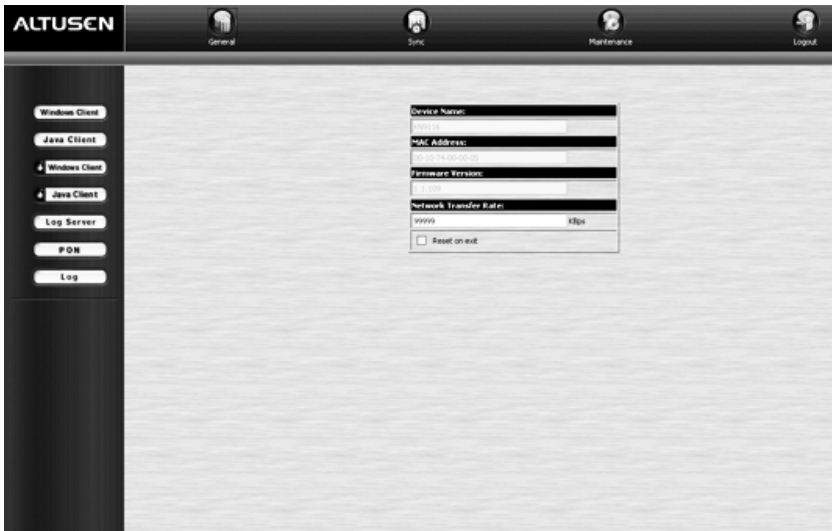

- Note:**
1. This is the same dialog box that appears whenever you click the *General* icon at the top left of the page.
 2. This screen depicts an Administrator's page. Depending on a user's type and permissions, not all of these elements appear.
 3. When logging in from the Local Console, the *Maintenance* and *PON* icons do not appear.
-

Web Page Layout

There are four icons at the top of the web page: General; Sync; Maintenance; and Logout, as follows:

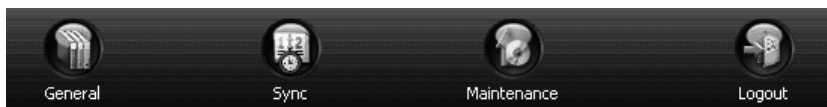

The General Dialog Box





An explanation of the General dialog box fields is given in the table below:

Field	Purpose
Device Name	To make it easier to manage installations that have more than one KN9108 / KN9116
MAC Address	The KN9108 / KN9116's MAC Address displays here.
Firmware Version	Indicates the KN9108 / KN9116's current firmware version level.
Network Transfer Rate	This displays the rate at which the KN9108 / KN9116 transfers data between the switch and the client computers. The range is from 4–99999 Kilobytes per second (KBps). See <i>Network Transfer Rate</i> , page 41 for details.
Reset on exit	To save any configuration/administration changes that you have made in the KN9108 / KN9116's OSD, place a check here to have the KN9108 / KN9116 implement the changes you have made and reset itself when you log out. Note: This checkbox is only enabled for users who have administration privileges.
Last IP from DHCP server	Displays the current IP address of the KN9108 / KN9116.

Note: New versions of the KN9108 / KN9116's firmware can be downloaded from our website as they become available. See *Upgrading the Firmware*, page 58, for details.

Web Page Icons

The purpose of the other icons at the top of the web page are explained in the table below:

Icon	Function
	<p>Click this icon to synchronize the KN9108 / KN9116's time with your computer's time.</p> <ul style="list-style-type: none"> ◆ If both are in the same time zone, the device's time is changed to match the computer's time. ◆ If they are in different time zones, the device's time is changed to match the computer's time, except that the time zone difference is still maintained.
	<p>Click this icon to install new versions of the KN9108 / KN9116's firmware (See <i>Upgrading the Firmware</i>, page 58, for details), or download your own private encryption key and private CA (See <i>Private Certificate</i>, page 59, for details)</p> <p>Note: The Maintenance icon only displays for users with administrative permission. It doesn't appear on the web pages of users who don't have the proper permission.</p>
	<p>You should always click this icon to log out and end your KN9108 / KN9116 session. If you close the browser without first logging out, you will have to wait approximately one minute before logging in again.</p>

Maintenance

The *Maintenance* page allows the Administrator to upgrade the KN9108 / KN9116's firmware, and to download a private encryption key and signed certificate.

Upgrading the Firmware

As new versions of the KN9108 / KN9116 firmware become available, they can be downloaded from our website.

Note: Although upgrading the firmware isn't on the OSD Administration page, it is an administrative function, so we will discuss it in this chapter.

To upgrade the firmware, do the following:

1. Download the new firmware file to a computer that is not part of your KN9108 / KN9116 installation.
2. From that computer, open your browser and log in to the KN9108 / KN9116 (see *Logging In*, page 15).
3. Click the **Maintenance** icon (see page 55) to open the *Firmware configuration* dialog box:



4. Click **Browse**; navigate to the directory that the new firmware file is in and select the file.
5. Click **Upgrade**.
6. After the upload completes, click the **Logout** icon to exit and reset the KN9108 / KN9116.

Private Certificate

When logging in over a secure (SSL) connection, a signed certificate is used to verify that the user is logging in to the intended site. For enhanced security, the *Private Certificate* section allows you to use your own private encryption key and signed certificate, rather than the default ATEN certificate.

To do this, click the **Maintenance** icon (see page 55) to open the *Private Certificate* dialog box:



There are two methods for establishing your private certificate: generating a self-signed certificate; and importing a third-party certificate authority (CA) signed certificate.

Generating a Self-Signed Certificate

If you wish to create your own self-signed certificate, a free utility – openssl.exe – is available for download over the web. See *Self-Signed Private Certificates*, page 133 for details about using OpenSSL to generate your own private key and SSL certificate.

Obtaining a CA Signed SSL Server Certificate

For the greatest security, we recommend using a third party certificate authority (CA) signed certificate. To obtain a third party signed certificate, go to a CA (Certificate Authority) website to apply for an SSL certificate. After the CA sends the certificate, save it to a convenient location on your computer.

Importing the Private Certificate





To import the private certificate, do the following:

1. Click **Browse** to the right of *Private Key*; browse to where your private encryption key file is located; and select it.
2. Click **Browse** to the right of *Certificate*; browse to where your certificate file is located; and select it.
3. Click **Upload** to complete the procedure.

Note: Both the private encryption key and the signed certificate must be changed at the same time.

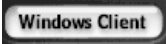
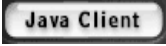
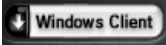
Web Page Buttons

The purpose of the buttons at the left of the web page are explained in the table below:

Icon	Purpose
	Click this button to open the WinClient ActiveX Viewer software to remotely control the KN9108 / KN9116 and the devices connected to it. See <i>Activating the WinClient ActiveX Viewer</i> , page 61.
	For platform independence, the Java client allows users that have Java installed to connect to the KN9108 / KN9116. Click this button to open the Java Applet Viewer software to remotely control the KN9108 / KN9116 and the devices connected to it. See <i>Activating the Java Applet Viewer</i> , page 62.
	In some instances, administrators don't want the KN9108 / KN9116 to be accessible by browser. Clicking this button allows the user to download the AP version of the Windows Client. Once a user has downloaded the AP program, the administrator can turn off browser access.
	In some instances, administrators don't want the KN9108 / KN9116 to be accessible by browser. Clicking this button allows the user to download the AP version of the Java Client. Once a user has downloaded the AP program, the administrator can turn off browser access.
	Clicking this button allows the administrator to download and install the Log Server application. See <i>The Log Server</i> , page 99 for Log Server details.
	If a Power on the NET™ (PON) module is connected to the KN9108 / KN9116, clicking this button brings up it's interface.
	All the events that take place on the KN9108 / KN9116 are recorded in a log file. Clicking this icon displays the contents of the log file. See <i>The Log File</i> , page 97.

Activating the WinClient ActiveX Viewer

After you have successfully logged in (see *Browser Login*, page 16), to activate the browser-based WinClient ActiveX Viewer do the following:

1. Click the *Windows Client* button (the one without the arrow) at the left of the web page.

Note: 1. You must have DirectX 8.0 or higher installed on your computer. If not, the WinClient ActiveX Viewer will not load. If you don't already have it, DirectX is available for free download from Microsoft's website: <http://www.microsoft.com/downloads>.

2. The Windows Client button with the arrow is for running the AP version of the Windows Client.
-

2. Accept the security certificates.
3. When you bring up the OSD, the Main Screen comes up in the center of your monitor. Turn to *The Main Page*, page 63, for further information

Activating the Java Applet Viewer

After you have successfully logged in (see page 16), to activate the Java Applet Viewer, do the following:

1. Click the *Java Client* button (the one without the arrow) at the left of the web page.

Note: You must have the latest version of Sun's Java Runtime Environment (JRE) installed on your computer before running the Java Client. Java is available for free download from the Sun Java website: <http://java.sun.com>.

2. Accept the security certificates.
3. When you bring up the OSD, the Main Screen comes up in the center of your monitor. Turn to *The Main Page*, page 63, for further information

Chapter 6

The User Interface

Overview

Once you have successfully logged in (see *Logging In*, page 15), activate the browser-based OSD. The look of the user interface main page varies slightly, depending on which method you used to log in (WinClient ActiveX Viewer, WinClient AP Control Panel, Java Applet Viewer, or Java Client AP Control Panel). The functions are described fully in the sections that follow.

The Main Page

The OSD comes up with the *Main* page displayed:

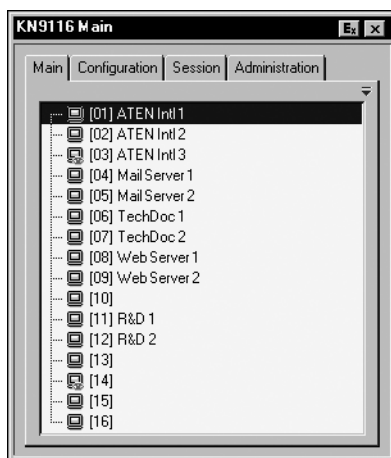

-
- Note:**
1. The *Administration* tab is disabled for users who don't have administration permission. For those who do have administration permission, administration operations are discussed in Chapter 4.
 2. There is a small Control Panel that appears above the Main page when you mouse over the top toolbar. This is discussed in detail on page 72.
-

There are two buttons on the title bar at the top right. They are described below starting from the left and moving to the right:

- ◆ *Log out*: clicking this button (or pressing F8) closes the OSD display and logs you out of the KN9108 / KN9116 session.
- ◆ *Close*: clicking this button closes the OSD display but does not log you out of the session. You can bring the display back with the OSD hotkeys (see *OSD Hotkey*, page 95).

Note: The Screen View and Transparent buttons are available on the Local Console OSD only (See page 25).

The Main Page lists all of the KN9108 / KN9116's ports. You access the computers connected to its ports by selecting them on this page.

Details regarding the meaning and operation of the main page elements are provided in Chapter 4, *Administration*.

Port Operation

Select a port on the OSD Main Screen either by moving the highlight bar to it with the Up and Down Arrow keys and pressing **Enter**, or by **double-clicking** it. Once you select a port, its screen displays on your monitor, and your keyboard and mouse input affects the remote system.

The OSD Toolbar

The OSD provides a toolbar to help you control the KN9108 / KN9116 from within the captured port. Depending on which method you used to log in, the toolbar differs slightly (See note 2, below). To bring up the toolbar, tap the OSD Hotkey twice (Scroll Lock or Ctrl). The toolbar appears at the upper left corner of the screen:

Local OSD



Remote OSD



Depending on the settings that were selected under *ID Display* (see page 95), the Port Number and/or the Port Name display at the right of the toolbar.

-
- Note:** 1. When the toolbar displays, mouse input is confined to the toolbar area and keyboard input has no effect. To carry out operations on the computer connected to the port, close the toolbar by clicking the **X** on it; or, recall the OSD and select the port again.
2. The Local OSD toolbar exclusively has the *Switch Opaque/Transparent* function; the Remote OSD toolbar exclusively has the *Panel Array Mode* function. See the icons in the table on the following page for details.
-

Recalling the OSD

To dismiss the toolbar and bring back the OSD display (the Main, Configuration, and Administration pages), do one of the following:

- ♦ tap the OSD Hotkey once;
- ♦ or, from the toolbar click the icon that brings up the OSD (see page 66).

The OSD Toolbar closes, and the main OSD display reappears.











OSD Hotkey Summary Table

The following table presents a summary of the OSD Hotkey actions. To set the OSD Hotkey, see *OSD Hotkey*, page 95.

To...	When...	Do This...
Open the OSD Toolbar	The OSD Toolbar is not open.	Click the OSD Hotkey twice.
Open the OSD	The OSD Toolbar is open.	Click the OSD Hotkey once.
Open the OSD	The OSD Toolbar is not open.	Click the OSD Hotkey three times.

The Toolbar Icons

The meanings of the toolbar icons are explained in the table below

	Click to skip to the first accessible port on the entire installation without having to invoke the OSD.
	Click to skip to the first accessible port previous to the current one without having to invoke the OSD.
	Click to begin <i>Auto Scan Mode</i> . The KN9108 / KN9116 automatically switches among the ports that were selected for Auto Scanning under the Configuration <i>Scan Select</i> function (see <i>Scan Select</i> , page 95). This allows you to monitor their activity without having to switch among them manually.
	Click to skip from the current port to the next accessible one without having to invoke the OSD.
	Click to skip from the current port to the last accessible port on the entire installation without having to invoke the OSD.
	Click to bring up the OSD.
	Click to close the toolbar.
	Click to logout and exit the WinClient ActiveX Viewer application.
	Local OSD only: Click to switch toolbar to <i>Transparent/Opaque Mode</i> .
	Remote OSD only: Click to invoke <i>Panel Array Mode</i> (see page 69).

Note: The administrator selects which ports are accessible to each user with the *User Management* function (see page 36 for details).

Hotkey Operation

Hotkeys allow you to provide KVM focus to a port directly from the keyboard. The KN9108 / KN9116 provides the following hotkey features:

- ◆ Auto Scanning
- ◆ Skip Mode Switching

The hotkeys are: **A** and **P** for Auto Scanning; and the Arrow Keys for Skip Mode.

Note: 1. In order for hotkey operations to take place, the OSD Toolbar must be visible (see *Port Operation*, page 65). To use the keys designated as hotkeys (i.e. A, P, etc.) for normal, non-hotkey purposes, you must first close the toolbar.

2. For issues affecting multiple user operation in Auto Scan Mode, see *Multiuser Operation*, page 71.
-

Auto Scanning

The Auto Scan function automatically switches among all the ports that are accessible to the currently logged on User at regular intervals, so that the user can monitor their activity automatically. (See *Scan Select*, page 95, for information regarding accessible ports.)

Setting the Scan Interval

The amount of time Auto Scan dwells on each port is set with the *Scan Duration* setting (see page 95).

Invoking Auto Scan

To start Auto Scanning, tap the **A** key. The Auto Scan function cycles through the ports in order - starting from the first port on the installation. An **S** appears in front of the Port ID Display to indicate that the port is being accessed under Auto Scan Mode.

Pausing Auto Scan

While you are in Auto Scan Mode, you can pause the scanning in order to keep the focus on a particular computer by pressing **P**. During the time that Auto Scanning is paused, the **S** in front of the Port ID blinks On and Off.

Pausing when you want to keep the focus on a particular computer is more convenient than *Exiting Auto Scan Mode* because when you Resume scanning, you start from where you left off. If, on the other hand, you were to exit and restart Auto Scan Mode, the scanning would start from the very first computer on the installation. To resume Auto Scanning, press any key except Esc or the Spacebar. Scanning continues from where it left off.

Exiting Auto Scan

While Auto Scan Mode is in effect, ordinary keyboard functions are suspended. You must exit Auto Scan Mode in order to regain normal control of the keyboard. To exit Auto Scan Mode press **Esc** or the **Spacebar**. Auto Scanning stops when you exit Auto Scan Mode.

Skip Mode

Skip Mode allows you to switch ports in order to monitor the computers manually. You can dwell on a particular port for as long or as little as you like - as opposed to Auto Scanning, which automatically switches after a fixed interval. The Skip Mode hotkeys are the four Arrow keys. Their operation is explained in the table below:

Arrow	Action
←	Skips from the current port to the first accessible port previous to it. (See <i>Scan Select</i> , page 95, for information regarding accessible ports.)
→	Skips from the current port to the first accessible port that comes after it.
↑	Skips from the current port to the very first accessible port on the installation.
↓	Skips from the current port to the very last accessible port on the installation.

Panel Array Mode

Clicking on the OSD Toolbar's *Panel* icon invokes Panel Array Mode. Under this mode, the OSD divides your screen into a 4 x 4 grid of 16 panels:

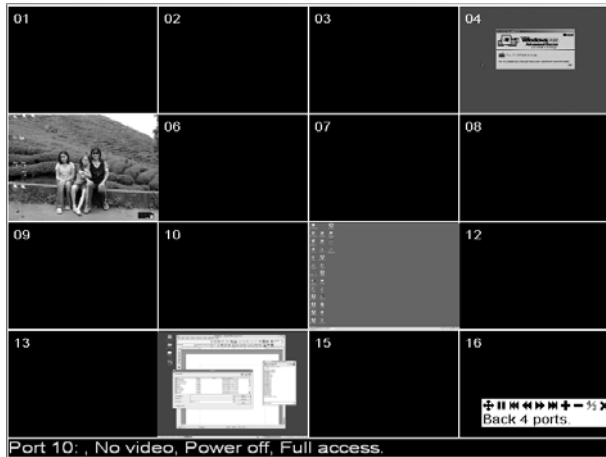











- ◆ Each panel represents one of the KN9108 / KN9116's ports. Starting with Port 1 at the upper left; going from left to right; top to bottom; Port 16 is at the lower right.
- ◆ When the Array is first invoked, it scans through each of the ports that were selected for Auto Scanning under the Configuration page's *Scan Select* function (see page 95), and displays information about the port (port name, resolution, on line status, port access status), at the bottom of the panel.
- ◆ The number of panels in the array (16, 9, 4, or 1) can be selected by clicking **Show More Ports (+)**, and **Show Fewer Ports (-)** on the panel array toolbar.
- ◆ If the computer connected to a port is on line, its screen displays in its panel, otherwise the panel is blank.
- ◆ Only ports that are accessible to the currently logged in user display (see *Port Access*, page 38). All other panels are blank.
- ◆ If you move the mouse pointer over a panel, information about the port displays at the bottom of the screen.

(Continues on next page.)

(Continued from previous page.)

- ♦ You can access a computer connected to a port by moving the mouse pointer over its panel and clicking. You switch to the computer exactly as if you had selected it from the OSD Main screen.
- ♦ The panel array toolbar, at the lower right of the screen, provides shortcut navigation and control of the panel array as described in the diagram below:

	Click the pushpin to have the toolbar always be on top.
	Pause panel scanning, leaving the focus on the panel that currently has it.
	Move back four panels.
	Move to the previous panel.
	Move to the next panel.
	Move ahead four panels.
	Show More Ports: Increase the number of panels in the array.
	Show Fewer Ports: Decrease the number of panels in the array.
	Toggle 4/3 aspect ratio.
	Exit Panel Array mode.

- ♦ For issues affecting multiple user operation in Panel Array Mode, see *Multiuser Operation*, page 71.

Multiuser Operation

The KN9108 / KN9116 supports multiuser operation. Up to 32 users can log in at the same time. When multiple users simultaneously access the KN9108 / KN9116 switch from remote consoles, the rules of precedence that apply are shown in the following table:

Operation	Rule
General	<ul style="list-style-type: none"> ◆ Once a user invokes the OSD, no other user can invoke it until the original user closes it.
Auto Scan Mode	<ul style="list-style-type: none"> ◆ If a user has invoked Auto Scan Mode (see <i>Auto Scanning</i>, page 67), but the OSD has not been invoked, another user can interrupt Auto Scan Mode by invoking the OSD.
Panel Array Mode	<ul style="list-style-type: none"> ◆ When a user has invoked Panel Array Mode (see page 69), all successive users automatically enter Panel Array Mode. Panel Array Mode continues until the original user stops it. (Administrators can override Panel Array Mode.) ◆ Only the user who starts Panel Array Mode can use the Skip Mode (see page 68) function. ◆ Only the user who starts Panel Array Mode can switch ports. Other users automatically switch to the ports that the original user selects. However, if an individual user does not have access rights to the port that the original user switches to, the user will not be able to view that port. ◆ Individual users can increase or decrease the number of panels they wish to view in Panel Array Mode; however, the picture quality may decrease as the number of panels decreases.

Note: ATEN recommends that the user who starts Panel Array Mode set it to display at least four panels; otherwise, it is possible that other users may receive only part of the picture.

Control Panel

Since the WinClient ActiveX Viewer and WinClient AP Control Panel contains the most complete functionality of all the user interface control panels, this section describes the WinClient Control Panel. Although the other control panels may not have all of the features that this one does, you can refer to the information described here when using them.

The control panel consists of an icon bar at the top, with two text bars below it; as shown:



Note: The above image shows the complete Control Panel. The icons that appear can be customized. See *Control Panel Configuration*, page 91, for details.

- ♦ By default, the top text row shows the video resolution of the remote display. As the mouse pointer moves over the icons in the icon bar, however, the information in the top text row changes to describe the icon's function. In addition, if a message from another user is entered in the message board, and you have not opened the message board in your session, the message will appear in the top row.
- ♦ The lower row shows the IP address of the device you are accessing at the left. In the center of the bar, the number before the slash indicates which bus the user is on, while the number behind the slash indicates the number of users on that bus.

(Continues on next page.)











(Continued from previous page.)

- ◆ Right clicking in the text row area brings up a menu that allows you to select options for the *Screen Mode*, *Zoom* and *Macro List*. These functions are discussed in the sections that follow.



- ◆ To move the Control Panel to a different location on the screen, place the mouse pointer over the text bar area, then click and drag.

Control Panel Functions

Icon	Function
	This is a toggle. Click to make the Control Panel persistent – i.e., it always displays on top of other screen elements. Click again to have it display normally.
	Click to bring up the Macros dialog box (see page 76 for details).
	Click to bring up the Video Options dialog box. Right-click to perform a quick Auto Sync (see <i>Video Settings</i> , page 82, for details).
	Toggles the display between <i>Full Screen Mode</i> and <i>Windowed Mode</i> .
	Click to take a snapshot (screen capture) of the remote display. See <i>Snapshot</i> , page 92, for details on configuring the Snapshot parameters.
	Click to bring up the Message Board (see <i>The Message Board</i> , page 86).
	Click to send a <i>Ctrl+Alt+Del</i> signal to the remote system.
	Click to bring up the on-screen keyboard (see <i>The On-Screen Keyboard</i> , page 89).
	Click to display a dropdown Macro List of <i>User</i> macros. Access and run macros more conveniently rather than using the Macros dialog box (see the <i>Macros</i> icon in the table above, and the <i>Macros</i> section on page 76).
	Click to bring up the Control Panel Configuration dialog box. See <i>Control Panel Configuration</i> , page 91, for details on configuring the Control Panel.
	Click to exit the remote view.

(Continues on next page.)

(Continued from previous page.)



These icons show the Num Lock, Caps Lock, and Scroll Lock status of the remote computer.

- ◆ When the lock state is *On*, the LED is bright green and the lock hasp is closed.
- ◆ When the lock state is *Off*, the LED is dull green and the lock hasp is open.

Click on the icon to toggle the status.

Note: These icons and your local keyboard icons are in sync. Clicking an icon causes the corresponding LED on your keyboard to change accordingly. Likewise, pressing a Lock key on your keyboard causes the icon's color to change accordingly.

The *Hotkey Setup*, *Video Options* and *Message Board* functions are discussed in the sections that follow.

Macros

The Macros icon provides access to two functions found in the Macros dialog box: Hotkeys and User Macros. Both are described in the following sections.

Note: The **T** button at the top right of the dialog boxes that appear for the Macros function brings up a slider to adjust the transparency of the dialog box. After making your adjustment, click anywhere in the dialog box to dismiss the slider.

Hotkeys

Various actions, corresponding to clicking the Control Panel icons, can be accomplished directly from the keyboard with hotkeys. Selecting the Hotkeys radio button lets you configure which hotkeys perform the actions. The actions are listed to the left; their hotkeys are shown to the right. Use the checkbox to the left of an action's name to enable or disable its hotkey.

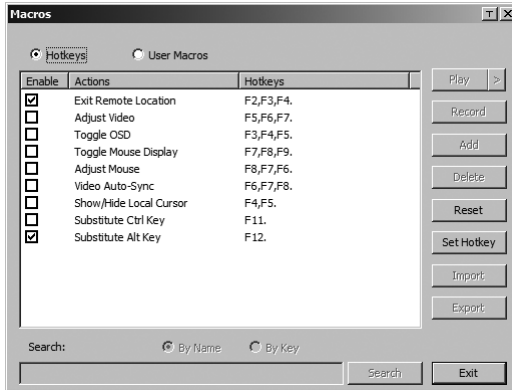

If you find the default Hotkey combinations inconvenient, you can reconfigure them as follows:

1. Highlight an *Action*, then click **Set Hotkey**.
2. Press your selected Function keys (one at a time). The key names appear in the *Hotkeys* field as you press them.
 - ◆ You can use the same function keys for more than one action, as long as the key sequence is not the same.
 - ◆ To cancel setting a hotkey value, click **Cancel**; to clear an action's Hotkeys field, click **Clear**.
3. When you have finished keying in your sequence, click **Save**.

To reset all the hotkeys to their default values, click **Reset**.

An explanation of the Hotkey actions is given in the table below:

Action	Explanation
Exit remote location	If you are using the Java AP, this exits the remote view and goes back to the web browser Main Page. If you are using the WinClient AP, this exits remote view and goes back to the WinClient main page. This is equivalent to clicking the <i>Exit</i> icon on the Control Panel. The default keys are F2, F3, F4.
Adjust Video	Brings up the <i>Video Settings</i> dialog box. This is equivalent to clicking the <i>Video Settings</i> icon on the Control Panel. The default keys are F5, F6, F7.
Toggle OSD	Toggles the Control Panel Off and On. The default keys are F3, F4, F5.
Toggle mouse display	If you find the display of the two mouse pointers (local and remote) to be confusing or annoying, you can use this function to shrink the non-functioning pointer down to a barely noticeable tiny circle, which can be ignored. Since this function is a toggle, use the hotkeys again to bring the mouse display back to its original configuration. This is equivalent to selecting the <i>Dot</i> pointer type from the <i>Mouse Pointer</i> icon on the Control Panel. The default keys are F7, F8, F9. Note: The Java Control Panel does not have this feature.
Adjust mouse	This synchronizes the local and remote mouse movements. The default keys are F8, F7, F9.
Video Auto-sync	This combination performs an auto-sync operation. It is equivalent to clicking the <i>Video Autosync</i> icon on the Control Panel. The default keys are F6, F7, F8.
Show/Hide Local Cursor	Toggles the display of your local mouse pointer off and on. This is equivalent to selecting the <i>Null</i> pointer type from the <i>Mouse Pointer</i> icon on the Control Panel. The default keys are F4,F5.
Substitute Ctrl key	If your local computer captures Ctrl key combinations, preventing them from being sent to the remote system, you can implement their effects on the remote system by specifying a function key to substitute for the Ctrl key. If you substitute the F11 key, for example, pressing [F11 + 5] would appear to the remote system as [Ctrl + 5]. The default key is F11.
Substitute Alt key	Although all other keyboard input is captured and sent to the remote system, [Alt + Tab] and [Ctrl + Alt + Del] work on your local computer. In order to implement their effects on the remote system, another key may be substituted for the Alt key. If you substitute the F12 key, for example, you would use [F12 + Tab] and [Ctrl + F12 + Del]. The default key is F12.

■ Search

Search, at the bottom of the dialog box, lets you filter the list of macros that appear in the large upper panel for you to play or edit. Click a radio button to choose whether you want to search by name or by Hotkey; key in a string for the search; then click **Search**. All instances that match your search string appear in the upper panel.

User Macros

User Macros are used to perform specific actions on the remote server. To create the macro, do the following:

1. Select *User Macros* radio button, then click **Add**.

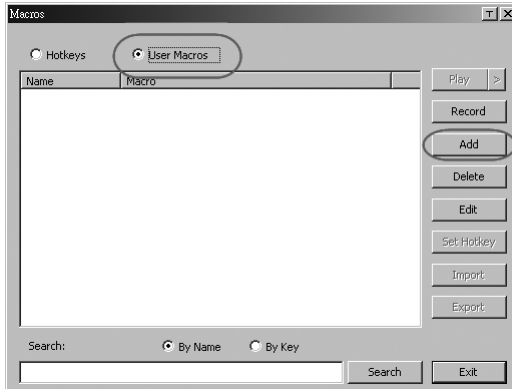

2. In the dialog box that comes up, replace the “New Macro” text with a name of your choice for the macro:

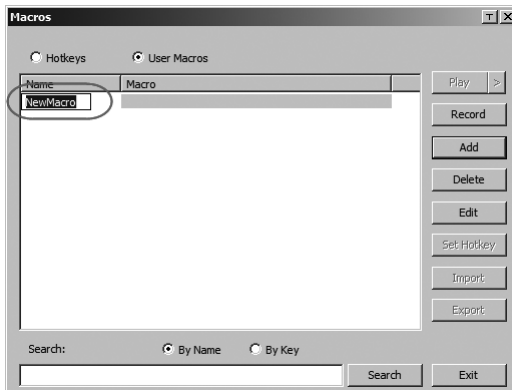

3. Click **Record**.

The dialog box disappears, and a small panel appears at the top left of the screen:



4. Press the keys for the macro.

- ◆ To pause macro recording, click **Pause**. To resume, click **Pause** again.
- ◆ Clicking **Show** brings up a dialog box that lists each keystroke that you make, together with the amount of time each one takes:

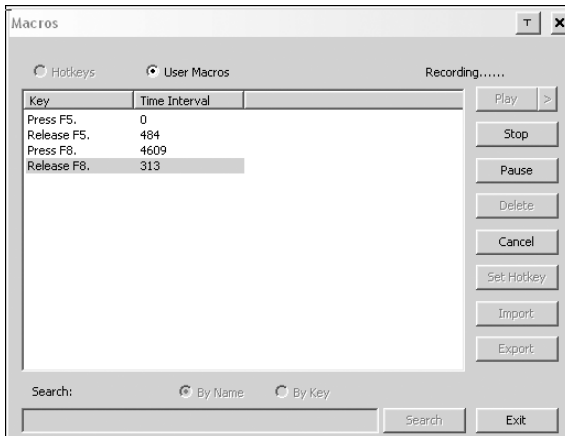

- ◆ Clicking **Cancel** cancels all keystrokes.
- ◆ When you have finished, click **Stop**. This is the equivalent of clicking Done in Step 5.

Note: 1. Case is not considered – typing **A** or **a** has the same effect.

2. When recording the macro the focus must be on the remote screen. It cannot be in the macro dialog box.
 3. Only the default keyboard characters may be used. Alternate characters cannot be used. For example, if the keyboard is Traditional Chinese and default character is **A** the alternate Chinese character obtained via keyboard switching is not recorded.
-

5. If you haven't brought up the Show dialog, click **Done** when you have finished recording your macro. You return to the Macros dialog box with your system macro key presses displayed in the Macro column:

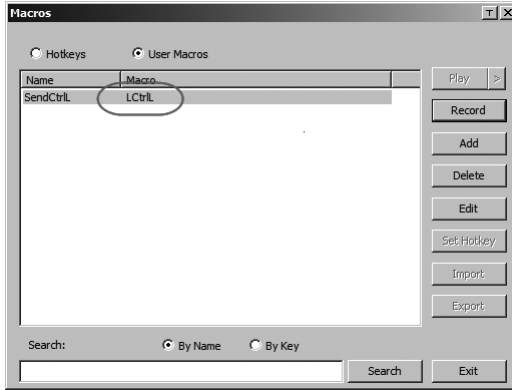

6. If you want to change any of the keystrokes, select the macro and click **Edit**. This brings up a dialog box similar to the one for Show. You can change the content of your keystrokes, change their order, etc.
7. Repeat the procedure for any other macros you wish to create.

After creating your macros, you can run them either by opening this dialog box and clicking **Play**, or by opening the Macro List on the Control Panel and clicking the one you want.

If you run the macro from this dialog box, you have the option of specifying how the macro runs, by clicking the arrow next to the Play button.



- ◆ If you choose *Play Without Wait*, the macro runs the keypresses one after another with no time delay between them.
- ◆ If you choose *Play With Time Control*, the macro waits for the amount of time between key presses that you took when you created it. Click on the arrow next to *Play* to make your choice.
- ◆ If you click *Play* without opening the list, the macro runs with the default choice. The default choice (*NoWait* or *TimeCtrl*), is shown in the *Playback* column.

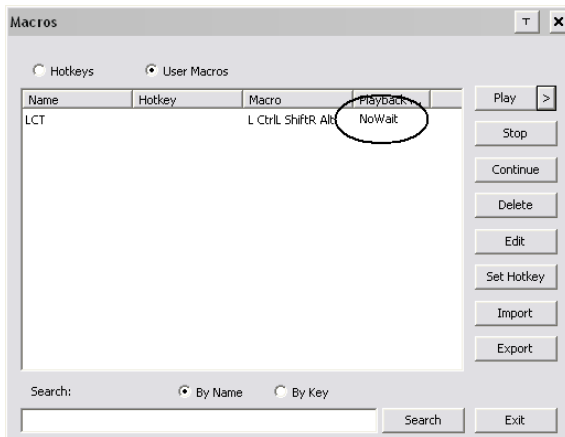

You can change the default choice by clicking on the current choice (*NoWait* in the screenshot shown), and selecting the alternative choice.

Note: 1. Information about the Search function is given on page 77.

2. User Macros are stored on the Local Client computer of each user. Therefore there is no limitation on the of number of macros, the size of the macro names, or makeup of the hotkey combinations that invoke them
-

Video Settings

Clicking the *Hammer* icon on the Control Panel brings up the *Video Settings* dialog box. The options in this dialog box allow you to adjust the placement and picture quality of the remote screen on your monitor

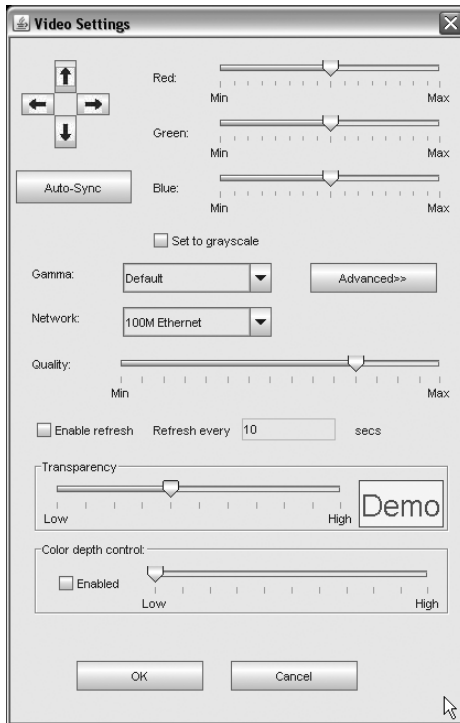

The meanings of the video adjustment options are given in the table on the following two pages:

Video adjustment options:

Options	Usage
Screen Position	Adjust the horizontal and vertical position of the remote server window by Clicking the Arrow buttons.
Auto-Sync	<p>Click Auto-Sync to have the vertical and horizontal offset values of the remote screen detected and automatically synchronized with the local screen.</p> <p>Note: 1. If the local and remote mouse pointers are out of sync, in most cases, performing this function will bring them back into sync.</p> <p>2. This function works best with a bright screen.</p> <p>3. If you are not satisfied with the results, use the Screen Position arrows to position the remote display manually.</p>
RGB	<p>Drag the slider bars to adjust the RGB (Red, Green, Blue) values. When an RGB value is increased, the RGB component of the image is correspondingly increased.</p> <p>If you enable <i>Set to Grayscale</i>, the remote video display is changed to grayscale.</p>
Gamma	<p>This section allows you to adjust the video display's gamma level. This function is discussed in detail in the next section, <i>Gamma Adjustment</i>.</p>
Network Type	<p>Select the type of internet connection that the local client computer uses. The switch will use that selection to automatically adjust the <i>Video Quality</i> and <i>Detect Tolerance</i> settings to optimize the quality of the video display.</p> <p>Since network conditions vary, if none of the pre-set choices seem to work well, you can select <i>Customize</i> and use the Video Quality and Detect Tolerance slider bars to adjust the settings to suit your conditions.</p>
Video Quality	<p>Drag the slider bar to adjust the overall Video Quality. The larger the value, the clearer the picture and the more video data goes through the network. Depending on the network bandwidth, a high value may adversely effect response time.</p>

Enable Refresh	<p>The KN9108 / KN9116 can redraw the screen every 1 to 99 seconds, eliminating unwanted artifacts from the screen. Select Enable Refresh and enter a number from 1 through 99. The KN9108 / KN9116 will redraw the screen at the interval you specify. This feature is disabled by default. Click to put a check mark in the box next to <i>Enable Refresh</i> to enable this feature.</p> <p>Note: 1. The switch starts counting the time interval when mouse movement stops.</p> <p>2. Enabling this feature increases the volume of video data transmitted over the network. The lower the number specified, the more often the video data is transmitted. Setting too low a value may adversely affect overall operating responsiveness.</p>
Transparency	Adjusts the transparency of the Control Panel and other Toolbars. Slide the bar until the display in the example window is to your liking.
Color Depth Control	This setting determines the richness of the video display by adjusting the amount of color information.

Gamma Adjustment

If it is necessary to correct the gamma level for the remote video display, use the *Gamma* function of the Video Adjustment dialog box.

- ◆ Under *Basic* configuration, there are ten preset and four user-defined levels to choose from. Drop down the list box and choose the most suitable one.
- ◆ For greater control, clicking the *Advanced* button brings up the following dialog box:

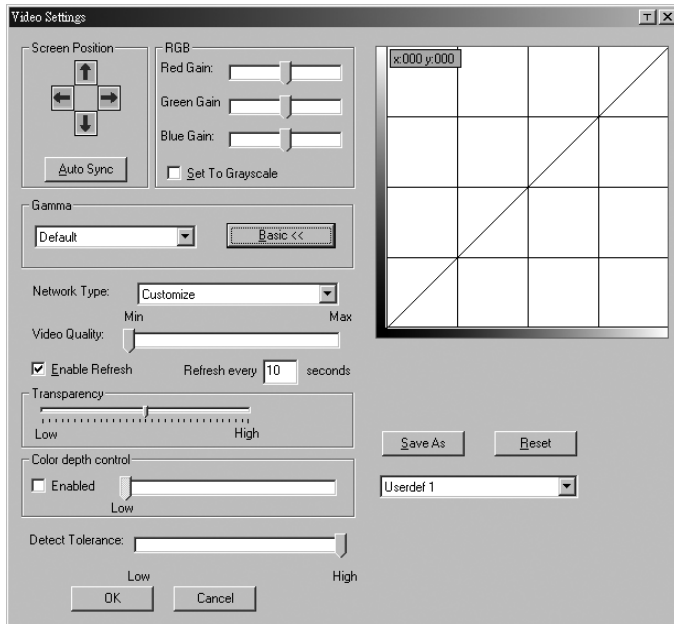

- ◆ Click and drag the diagonal line at as many points as you wish to achieve the display output you desire.
- ◆ Click **Save As** to save up to four user-defined configurations derived from this method. Saved configurations can be recalled from the list box at a future time.
- ◆ Click **Reset** to abandon any changes and return the gamma line to its original diagonal position.
- ◆ Click **OK** to save your changes and close the dialog box.
- ◆ Click **Cancel** to abandon your changes and close the dialog box.

Note: For best results, change the gamma while viewing a remote server.

The Message Board



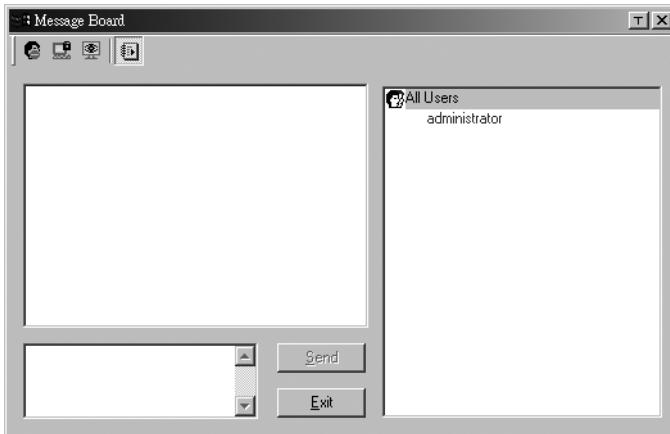

The KN9108 / KN9116 supports multiple user logins, which can possibly give rise to access conflicts. To alleviate this problem, a message board feature has been provided, allowing users to communicate with each other.

The message board functions much like an Internet chat program does. When you click the Message Board icon on the Control Panel (see page 72), a screen similar to the one below appears:



The Button Bar

The buttons on the Button Bar are toggles. Their actions are described in the table below:

Button	Action
	Enable/Disable Chat. When disabled, messages posted to the board are not displayed. The button is shadowed when Chat is disabled. The icon displays next to the user's name in the User List panel when the user has disabled Chat.
	Occupy/Release Keyboard/Video/Mouse. When you Occupy the KVM, other users cannot see the video, and cannot input keyboard or mouse data. The button is shadowed when the KVM is occupied. The icon displays next to the user's name in the User List panel when the user has occupied the KVM.
	Occupy/Release Keyboard/Mouse. When you Occupy the KM, other users can see the video, but cannot input keyboard or mouse data. The button is shadowed when the KM is occupied. The icon displays next to the user's name in the User List panel when the user has occupied the KM.
	Show/Hide User List. When you Hide the User List, the User List panel closes. The button is shadowed when the User List is open.

Message Display Panel

Messages that users post to the board - as well as system messages - display in this panel. If you disable Chat, however, messages that get posted to the board won't appear.

Compose Panel

Key in the messages that you want to post to the board in this panel. Click **Send**, or press [**Enter**] to post the message to the board.

User List Panel

The names of all the logged in users are listed in this panel.

- ◆ Your name appears in blue; other users' names appear in black.
- ◆ By default, messages are posted to all users. To post a message to one individual user, select the user's name before sending your message.
- ◆ If a user's name is selected, and you want to post a message to all users, select All Users before sending your message.
- ◆ If a user has disabled Chat, its icon displays before the user's name to indicate so.
- ◆ If a user has occupied the KVM or the KM, its icon displays before the user's name to indicate so.

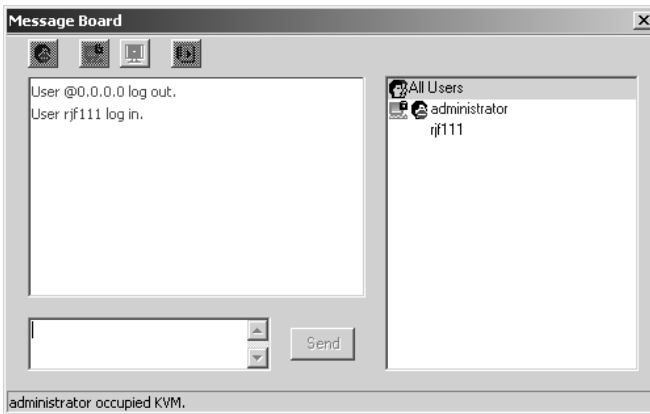

The On-Screen Keyboard

The KN9108 / KN9116 supports an on-screen keyboard, available in multiple languages, with all the standard keys for each supported language. Click this icon to pop up the on-screen keyboard:

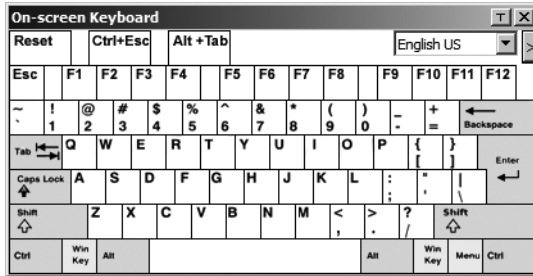

One of the major advantages of the on-screen keyboard is that if the keyboard languages of the remote and local systems aren't the same, you don't have to change the configuration settings for either system. The user just has to bring up the on-screen keyboard; select the language used by the server on the port he is accessing; and use the on-screen keyboard to communicate with it.

Note: You must use your mouse to click on the keys. You cannot use your actual keyboard.

To change languages, do the following:

1. Click the down arrow next to the currently selected language, to drop down the language list.

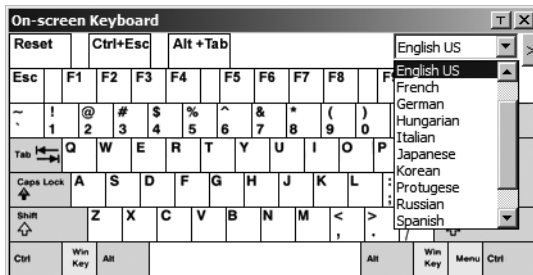

2. Select the new language from the list.

To display/hide the expanded keyboard keys, click the arrow to the right of the language list arrow.

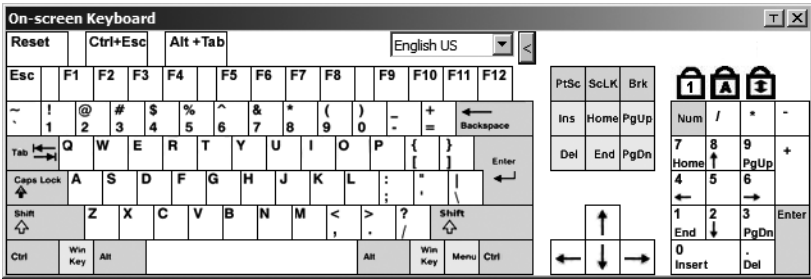

Control Panel Configuration

Clicking the *Control Panel* icon brings up a dialog box that allows you to configure the items that appear on the Control Panel, as well as its graphical settings. The dialog box differs slightly, depending on whether you use the WinClient ActiveX Viewer or the Java Applet Viewer:

WinClient ActiveX

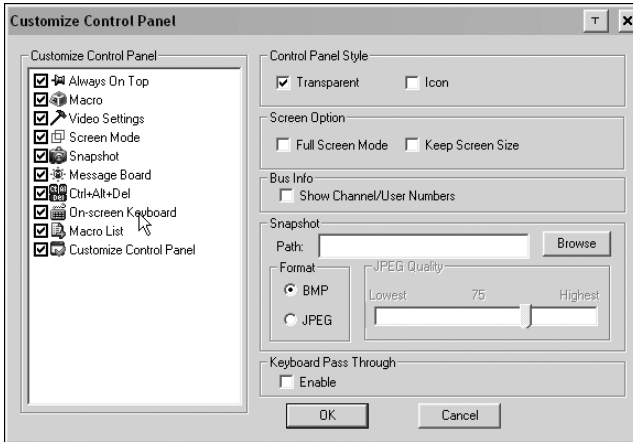

Java Applet

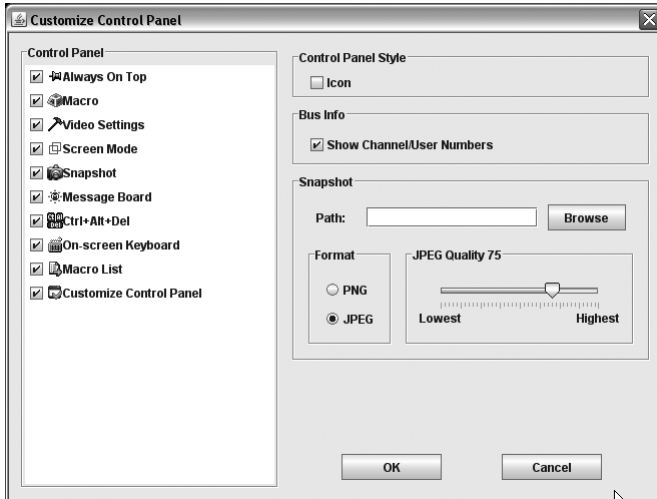

(Continues on next page.)

The dialog box is organized into six main sections as described, below:

Item	Description
Control Panel	Allows you to customize the Control Panel by selecting which icons display in the Control Panel
Control Panel Style	<ul style="list-style-type: none"> ◆ WinClient ActiveX Viewer only: Enabling <i>Transparent</i> makes the Control Panel semi-transparent, so that you can see through it to the display underneath. ◆ Enabling <i>Icon</i> causes the Control Panel to display as an icon until you mouse over it. When you mouse over the icon, the full panel comes up.
Screen Options	<p>WinClient ActiveX Viewer only:</p> <ul style="list-style-type: none"> ◆ If <i>Full Screen Mode</i> is enabled, the remote display fills the entire screen. ◆ If <i>Full Screen Mode</i> is not enabled, the remote display appears as a window on the local desktop. If the remote screen is larger than what is able to fit in the window, move the mouse pointer to the screen border that is closest to the area you want to view and the screen will scroll. ◆ If <i>Keep Screen Size</i> is enabled, the remote screen is not resized. <ul style="list-style-type: none"> ◆ If the remote resolution is smaller than that of the local monitor, its display appears like a window centered on the screen. ◆ If the remote resolution is larger than that of the local monitor, its display is centered on the screen. To access the areas that are off screen, move the mouse to the corner of the screen that is closest to the area you want to view and the screen will scroll. ◆ If <i>Keep Screen Size</i> is not enabled, the remote screen is resized to fit the local monitor's resolution.
Bus Info	If <i>Bus Info</i> is enabled, the number of the bus you are on, as well as the total number of users on the bus, displays on the bottom row center of the Control Panel as follows: Bus No./Total Users.
Snapshot	<p>These settings let the user configure the KN9108 / KN9116's screen capture parameters (see the <i>Snapshot</i> description under <i>Control Panel</i>, page 72):</p> <ul style="list-style-type: none"> ◆ Path lets you select a directory that the captured screens automatically get saved to. Click Browse; navigate to the directory of your choice; then click OK. If you don't specify a directory here, the snapshot is saved to your desktop. ◆ Click a radio button to choose whether you want the captured screen to be saved as a BMP or a JPEG (JPG) file. ◆ If you choose JPEG, you can select the quality of the captured file with the slider bar. The higher the quality, the better looking the image, but the larger the file size. <p>Note: The Java Applet Viewer supports PNG not BMP files.</p>
Keyboard Pass Through	WinClient ActiveX Viewer Only: When this is enabled, the Alt-Tab key press is passed to the remote server and affect that server. If it is not enabled, Alt-Tab acts on your local client computer.

Note: The WinClient ActiveX Viewer has three functions that the Java Applet Viewer does not: *Transparent*; *Screen Options*; and *Keyboard Pass Through*.

Mouse Synchronization

Until you close the KN9108 / KN9116 connection, mouse movements have no effect on your local system, but instead are captured and sent to the remote system.

From time to time, especially if you change video resolution, the local mouse movement may no longer be synchronized with the remote system's mouse pointer. There are three quick methods that can be used to bring the two pointers back into sync:

- ◆ Right-clicking on the hammer icon in the WinClient ActiveX Viewer Control Panel.
- ◆ Moving the mouse pointer into the Control Panel and back out again.
- ◆ Performing an *Auto Sync* with the Video Adjustment function (see *Video Settings*, page 82, for details).

If performing these actions does not resolve the problem, do the following:

1. Invoke the *Adjust Mouse* function with the *Adjust Mouse* hotkeys (see *Hotkey Operation*, page 67, for details).
2. Move the local mouse pointer exactly on top of the remote mouse pointer and click.

If this procedure still does not help, you should set the mouse speed and acceleration for each problematic computer attached to the switch.

See *Additional Mouse Synchronization Procedures*, page 131, for instructions.

The Configuration Page

The OSD *Configuration* page allows users to set up their own, individual, working environments. The KN9108 / KN9116 stores a separate configuration record for each user profile, and sets up the working configuration according to the *Username* that is used to log in.

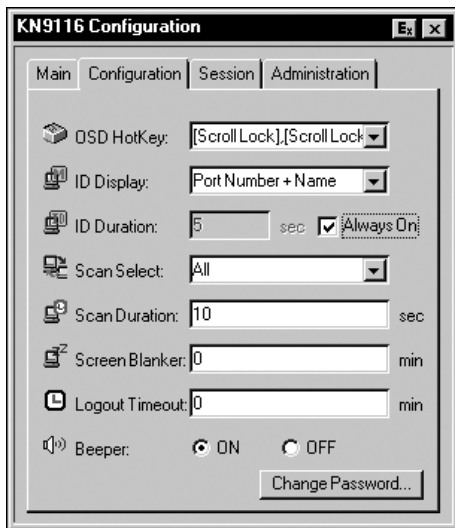

The Configuration page settings are explained in the following table:

Setting	Function
OSD Hotkey	Selects which Hotkey controls the OSD function: [Scroll Lock] [Scroll Lock] or [Ctrl] [Ctrl] . Since the Ctrl key combination may conflict with programs running on the computers, the default is the Scroll Lock combination. (See p. 67 for Hotkey operation.)
ID Display	Selects how the Port ID is displayed: the Port Number alone (PORT NUMBER); the Port Name alone (PORT NAME); or the Port Number plus the Port Name (PORT NUMBER + PORT NAME). The default is PORT NUMBER + PORT NAME.
ID Duration	Determines how long a Port ID displays on the monitor after a port change has taken place. You can choose an amount from 0 - 255 seconds. The default is 5 Seconds. Enable the <i>Always On</i> radio button for the Port ID to be always on.
Scan Select	Selects which computers will be accessed under Auto Scan Mode (see <i>Auto Scanning</i> , page 67). Choices are: ALL - All the Ports which have been set Accessible (see <i>Port Access</i> , page 38); POWERED ON - Only those Ports which have been set Accessible and are Powered On; QUICK VIEW - Only those Ports which have been set Accessible and have been selected as Quick View Ports (see <i>Quick View Ports</i> , page 27); QUICK VIEW + POWERED ON - Only those Ports which have been set Accessible and have been selected as Quick View Ports and are Powered On. The default is ALL.
Scan Duration	Determines how long the focus dwells on each port as it cycles through the selected ports in Auto Scan Mode (see <i>Auto Scanning</i> , page 67). Key in a value from 0 - 255 seconds. The default is 10 seconds; a setting of 0 disables the Scan function.
Screen Blanker	If there is no input from the console for the amount of time set with this function, the screen is blanked. Key in a value from 1 - 30 minutes. A setting of 0 disables this function. The default is 0 (disabled).
Logout Timeout	If there is no Operator input for the amount of time set with this function, the Operator is automatically logged out. A login is necessary before the KN9108 / KN9116 can be accessed again. Enter a value from 0 - 180 minutes. The default is 30 minutes. 0 disables the function.
Beeper	When set to ON , the beeper sounds whenever the port is switched, when activating the Auto Scan function (see <i>Auto Scanning</i> , page 67), or when an invalid entry is made on an OSD menu. The default is ON.
Change Password	Allows a user to change the account password. After clicking the Change Password button, a dialog box appears. Enter the old password. Then, enter a new password and confirm it by entering it again. Press OK to save changes, or press Cancel to discard changes.

This Page Intentionally Left Blank

Chapter 7

The Log File

The Main Screen

The KN9108 / KN9116 logs all the events that take place on it. To view the contents of the log file, click the *Log* icon at the left of the web page. A screen similar to the one below appears:



A maximum of 512 events are stored in the log file. To clear the log file, click on the *Clear Log* icon at the right of the screen.

Note: The Log File is a temporary file that is erased when the KN9108 / KN9116 is turned off or loses power. It is recommended that you install the Log Server to backup the contents of the log file.

This Page Intentionally Left Blank

Chapter 8

The Log Server

The Windows-based Log Server is an administrative utility that records all the events that take place on selected KN9108 / KN9116 units and writes them to a searchable database. This chapter describes how to install and configure the Log Server.

Installation

1. From the computer that you want to use as the Log Server, open your browser and log into the KN9108 / KN9116 (see page 15).
2. Click the *Log Server* button at the left of the web page to start the Log Server installation program.
3. If any security warning dialog boxes appear, ignore them and click **Run** or **Open**.

Note: If the browser cannot run the file, save it to disk, instead, and run the file from your disk.

The Log Server *Setup* screen comes up:



4. Click **Next**. Then follow the on-screen instructions to complete the installation and have the Log Server program icon placed on your desktop.

Starting Up

To bring up the Log Server, either double click the program icon, or key in the full path to the program on the command line. The first time you run it, a screen similar to the one below appears:

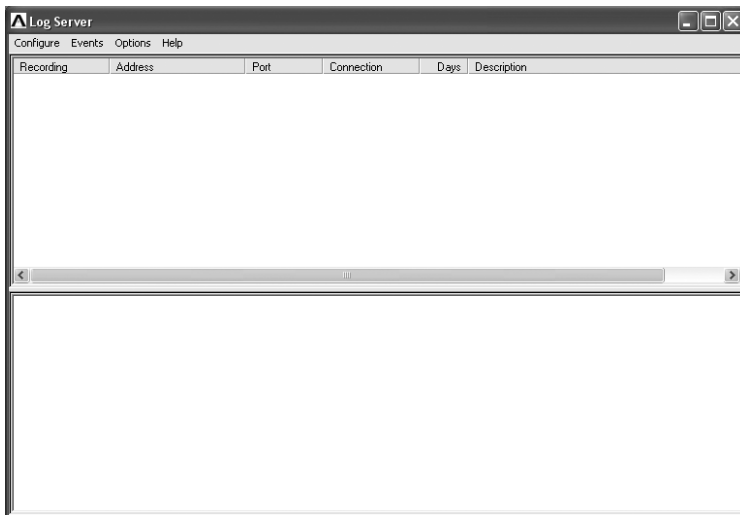

-
- Note:**
1. The MAC address of the Log Server computer must be specified on the *Service Configuration* page of the *Administrator Utility* (see page 39).
 2. The Log Server requires the Microsoft Jet OLEDB 4.0 driver in order to access the database.
-

The screen is divided into three components:

- ♦ A *Menu Bar* at the top
- ♦ A panel for a list of KN9108 / KN9116 units in the middle (see *Overview*, page 105).
- ♦ A panel for an *Events List* at the bottom (see *Overview*, page 105).

Each of the components is explained in the sections that follow.

The Menu Bar

The Menu bar consists of four items:

- ◆ Configure
- ◆ Events
- ◆ Options
- ◆ Help

These are discussed in the sections that follow.

Note: If the Menu Bar appears to be disabled, click in the KN9108 / KN9116 List window to enable it.

Configure

The Configure menu contains three items: Add, Edit, and Delete. They are used to add new KN9108 / KN9116 units to the KN9108 / KN9116 List, edit the information for units already on the list, or delete KN9108 / KN9116 units from the list.

- ◆ To add a KN9108 / KN9116 to the KN9108 / KN9116 List, click **Add**.
- ◆ To edit or delete a listed KN9108 / KN9116, first select the one you want in the KN9108 / KN9116 List window, then open this menu and click **Edit** or **Delete**.

When you choose *Add* or *Edit*, a dialog box, similar to the one below appears:

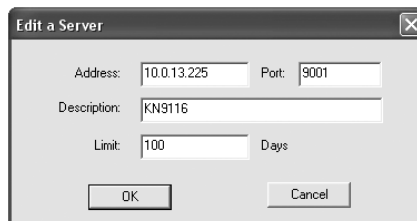

The screenshot shows a dialog box titled "Edit a Server". It contains the following fields and values:

Field	Value
Address:	10.0.13.225
Port:	9001
Description:	KN9116
Limit:	100
Days:	

At the bottom of the dialog are two buttons: "OK" and "Cancel".

A description of the fields is given in the table, below:

Field	Explanation
Address	This can either be the IP address of the KN9108 / KN9116 or its DNS name (if the network administrator has assigned it a DNS name).
Port	The Port number assigned to the KN9108 / KN9116 (see <i>Log Server</i> , page 40).
Description	This field is provided so that you can put in a descriptive reference for the unit to help identify it.
Limit	This specifies the number of days that an event should be kept in the Log Server's database before it expires and it is cleared out.

Fill in or modify the fields, then click **OK** to finish.

Events

The Events Menu has two items: *Search* and *Maintenance*.

Search

Search allows you to search for events containing specific words or strings. When you access this function, a screen similar to the one below appears:

The screenshot shows a 'Search Dialog' window with the following elements:

- Search Options:** Three radio buttons: 'New search' (selected), 'Search last results', and 'Search excluding last results'.
- Server List:** A text box containing the IP address '10.3.166.129'.
- Priority List:** A text box containing the words 'Least', 'Less', and 'Most' stacked vertically.
- Time and Date Selection:** Four fields with dropdown arrows: 'Start date' (11/29/2009), 'Start time' (10:17:37 AM), 'End date' (11/30/2009), and 'End time' (10:17:37 AM).
- Pattern:** An empty text box.
- Result:** A large empty text box for displaying search results.
- Buttons:** Four buttons at the bottom: 'Search', 'Print', 'Export', and 'Exit'.

A description of the items is given in the table below:

Item	Explanation
New search	This is one of three radio buttons that define the scope of the search. If it is selected, the search is performed on all the events in the database for the selected KN9108 / KN9116.
Search last results	This is a secondary search performed on the events that resulted from the last search.
Search excluding last results	This is a secondary search performed on all the events in the database for the selected KN9108 / KN9116 <i>excluding</i> the events that resulted from the last search.
Server List	KN9108 / KN9116 units are listed according to their IP address. Select the unit that you want to perform the search on from this list. You can select more than one unit for the search. If no units are selected, the search is performed on all of them.
Priority List	Sets the level for how detailed the search results display should be. 1 is the most general; 3 is the most specific.
Start Date	Select the date that you want the search to start from. The format follows the YY/MM/DD convention, as follows: 2005/11/04
Start Time	Select the time that you want the search to start from.
End Date	Select the date that you want the search to end at.
End Time	Select the time that you want the search to end at.
Pattern	Key in the pattern that you are searching for here. The multiple character wildcard (%) is supported. E.g., h%ds would match <i>hands</i> and <i>hoods</i> .
Results	Lists the events that contained matches for the search.
Search	Click this button to start the search.
Print	Click this button to print the search results.
Export	Click this button to export the search results.
Exit	Click this button to exit the Search dialog box.

Maintenance

This function allows the administrator to perform manual maintenance of the database. He can use it to erase specified records before the expiration time that was set with the *Limit* setting of the Edit function (see page 102).

Options

Network Retry allows you to set the number of seconds that the Log Server should wait before attempting to connect if the previous attempt to connect failed. When you click this item, a dialog box, similar to the one below appears:

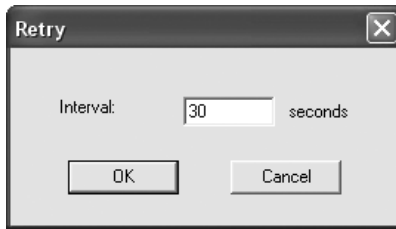

Key in the number of seconds, then click **OK** to finish.

Help

From the Help Menu, click Contents to access the online Windows Help file. The help file contains instructions about how to setup, operation and troubleshoot the Log Server.

The Log Server Main Screen

Overview

The Log Server Main Screen is divided into two main panels.

- ◆ The upper (List) panel lists the KN9108 / KN9116 units that have been selected for the Log Server to track (see *Configure*, page 101).
- ◆ The lower (Event) panel displays the log events for the currently selected KN9108 / KN9116 (the highlighted one - if there are more than one). To select a KN9108 / KN9116 unit in the list, simply click on it.

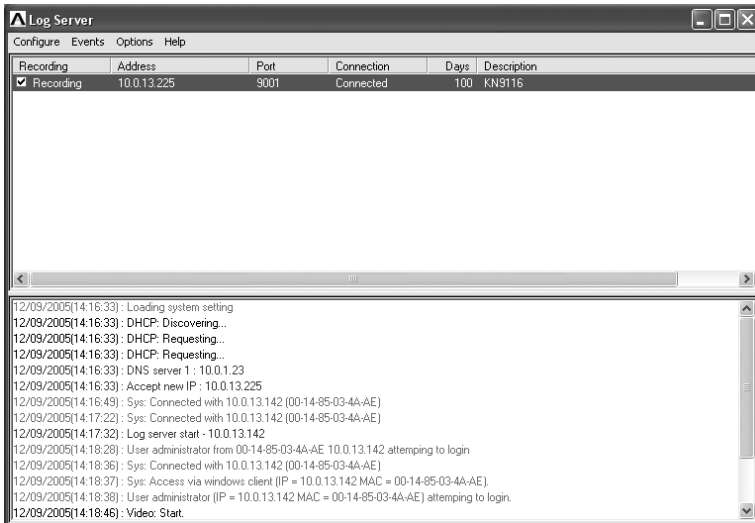

The List Panel

The List panel contains six fields:

Field	Explanation
Recording	Determines whether the Log Server records log events for this KN9108 / KN9116 or not. If the Recording checkbox is checked, the field displays <i>Recording</i> , and log events are recorded. If the Recording checkbox is not checked, the field displays <i>Paused</i> , and log events are not recorded. Note: Even though a KN9108 / KN9116 is not the currently selected one, if its Recording checkbox is checked, the Log Server will still record its log events.
Address	This is the IP Address or DNS name that was given to the KN9108 / KN9116 when it was added to the Log Server (see <i>Configure</i> , page 101).
Port	This is the Port number assigned to the KN9108 / KN9116 (see <i>Configure</i> , page 101).
Connection	If the Log Server is connected to the KN9108 / KN9116, this field displays <i>Connected</i> . If it is not connected, this field displays <i>Waiting</i> . This means that the Log Server's MAC address has not been set properly. It needs to be set on the <i>Service Configuration</i> page of the <i>Administrator Utility</i> (see page 39).
Days	This field displays the number of days that the KN9108 / KN9116's log events are to be kept in the Log Server's database before expiration (see <i>Configure</i> , page 101).
Description	This field displays the descriptive information given for the KN9108 / KN9116 when it was added to the Log Server (see <i>Configure</i> , page 101).

The Event Panel

The lower panel displays log events for the currently selected KN9108 / KN9116. Note that if there are more than one KN9108 / KN9116 units, even though they aren't currently selected, if their *Recording* checkbox is checked, the Log Server records their log events and keeps them in its database.

Chapter 9

LDAP Server Configuration

Introduction

The KVM Over the NET™ switch allows log in authentication and authorization through external programs. This chapter describes how to configure Active Directory for KVM Over the NET™ switch authentication and authorization.

To allow authentication and authorization via LDAP or LDAPS, the Active Directory's LDAP *Schema* must be extended so that an extended attribute name for the KVM Over the NET™ switch – *iKN2116-userProfile* – is added as an optional attribute to the *person* class.

Note: *Authentication* refers to determining the authenticity of the person logging in; *authorization* refers to assigning permission to use the device's various functions.

In order to configure the LDAP server, you will have to complete the following procedures: 1) Install the Windows Server Support Tools; 2) Install the Active Directory Schema Snap-in; and 3) Extend and Update the Active Directory Schema.

The following section provides an example of configuring LDAP under Windows 2003 Server.

Install the Windows 2003 Support Tools

To install the Windows 2003 Support Tools, do the following:

1. On your Windows Server CD, open the Support → Tools folder.
2. In the right panel of the dialog box that comes up, double click **SupTools.msi**.
3. Follow along with the Installation Wizard to complete the procedure.

Install the Active Directory Schema Snap-in

To install the Active Directory Schema Snap-in, do the following:

1. Open a Command Prompt.
2. Key in: `regsvr32 schmmgmt.dll` to register schmmgmt.dll on your Active Directory computer.
3. Open the *Start* menu; click **Run**; key in: `mmc /a`; click **OK**.
4. On the *File* menu of the screen that appears, click **Add/Remove Snap-in**; then click **Add**.
5. Under *Available Standalone Snap-ins*, double click **Active Directory Schema**; click **Close**; click **OK**.
6. On the screen you are in, open the *File* menu and click **Save**.
7. For *Save in*, specify the `C:\Windows\system32` directory.
8. For *File name*, key in **schmmgmt.msc**.
9. Click **Save** to complete the procedure.

Create a Start Menu Shortcut Entry

To create a shortcut entry on the Start Menu for the Active Directory Schema, do the following:

1. Right click Start; select: **Open all Users → Programs → Administrative Tools**.
2. On the *File* menu, select **New → Shortcut**
3. In the dialog box that comes up, browse to, or key in the path to schmmgmt.msc (`C:\Windows\system32\schmmgmt.msc`), then click **Next**.
4. In the dialog box that comes up, key in *Active Directory Schema* as the name for the shortcut, then click **Finish**.

Extend and Update the Active Directory Schema

To extend and update the Active Directory Schema, you must do the following 3 procedures: 1) create a new attribute; 2) extend the object class with the new attribute; and 3) edit the active directory users with the extended schema.

Creating a New Attribute

To create a new attribute do the following:

1. From the Start menu, open Administrative Tools → Active Directory Schema.
2. In the left panel of the screen that comes up, right-click **Attributes**:

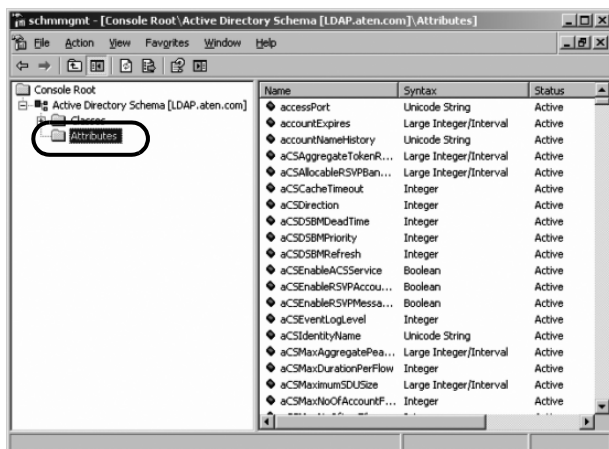

3. Select New → Attribute.
4. In the warning message that appears, click **Continue** to bring up the *Create New Attribute* dialog box.

(Continues on next page.)

(Continued from previous page.)

5. Fill in the dialog box to match the entries for *Description* and *Common Name* shown below, then click **OK** to complete the procedure.

Note: The Unique X500 Object ID uses periods, not commas.

The screenshot shows the 'iKVM2116-userProfile Properties' dialog box with the 'General' tab selected. The dialog contains the following fields and options:

- Description:** iKVM2116-userProfile
- Common Name:** iKVM2116-userProfile
- X500 Object ID:** 1.3.6.1.4.1.21317.1.1.4.25
- Syntax and Range:**
 - Syntax:** Unicode String
 - Minimum:** 1
 - Maximum:** 255
- Options:**
 - Allow this attribute to be shown in advanced view
 - Attribute is active
 - Index this attribute in the Active Directory
 - Ambiguous Name Resolution (ANR)
 - Replicate this attribute to the Global Catalog
 - Attribute is copied when duplicating a user
 - Index this attribute for containerized searches in the Active Directory

Buttons at the bottom: OK, Cancel, Apply.

Extending the Object Class With the New Attribute

To extend the object class with the new attribute, do the following:

1. Open the Control Panel → Administrative Tools → Active Directory Schema.
2. In the left panel of the screen that comes up, select **Classes**.
3. In the right panel, right-click **person**:

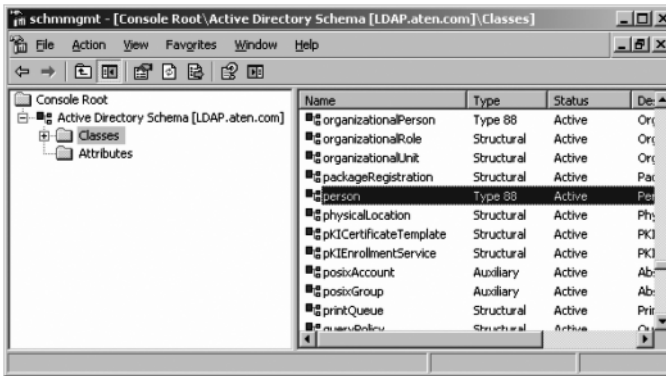

4. Select **Properties**; the *person Properties* dialog box comes up with the *General* page displayed. Click the *Attributes* tab.

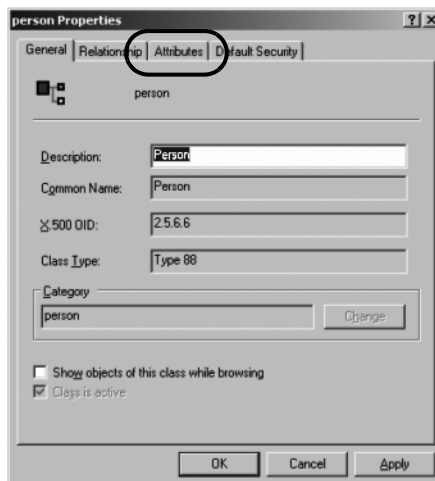

5. On the *Attributes* page, click **Add**:

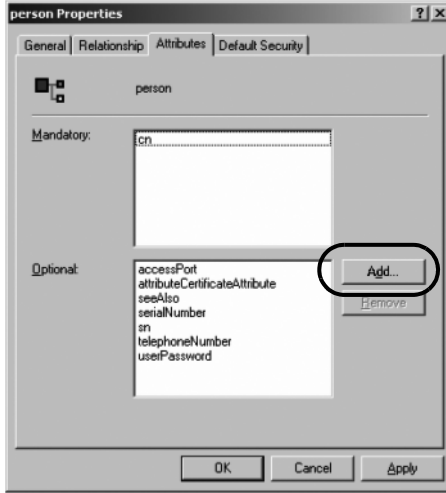

6. In the list that comes up, select **iKVM2116-userProfile**, then click **OK** to complete the procedure.



Editing Active Directory Users

To edit Active Directory Users With the Extended Schema, do the following:

1. Run **ADSI Edit**. (Installed as part of the *Support Tools*.)
2. In the left panel, open **Domain**, and navigate to the **DC=aten,DC=com** **CN=Users** node.
3. In the right panel, locate the user you wish to edit. (Our example uses *jason*.)

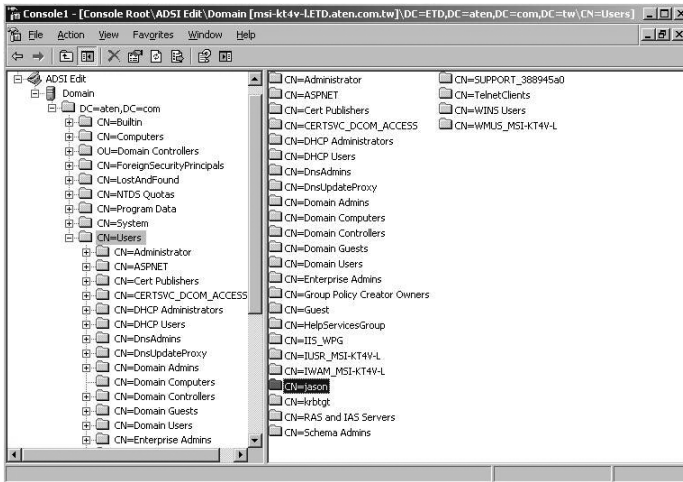

4. Right-click on the user's name and select **properties**.

(Continues on next page.)

(Continued from previous page.)

5. On the *Attribute Editor* page of the dialog box that appears, select **iKVM2116-userProfile** from the list.



6. Click **Edit** to bring up the *String Attribute Editor*:



(Continues on next page.)

OpenLDAP

OpenLDAP is an Open source LDAP server designed for Unix platforms. A Windows version can be downloaded from:

```
http://download.bergmans.us/openldap/openldap-2.2.29/  
openldap-2.2.29-db-4.3.29-openssl-0.9.8a-  
win32_Setup.exe.
```

OpenLDAP Server Installation

After downloading the program, launch the installer, select your language, accept the license and choose the target installation directory. The default directory is: *c:\Program Files\OpenLDAP*.

When the *Select Components* dialog box appears, select *install BDB-tools* and *install OpenLDAP-slapd as NT service*, as shown in the diagram, below:

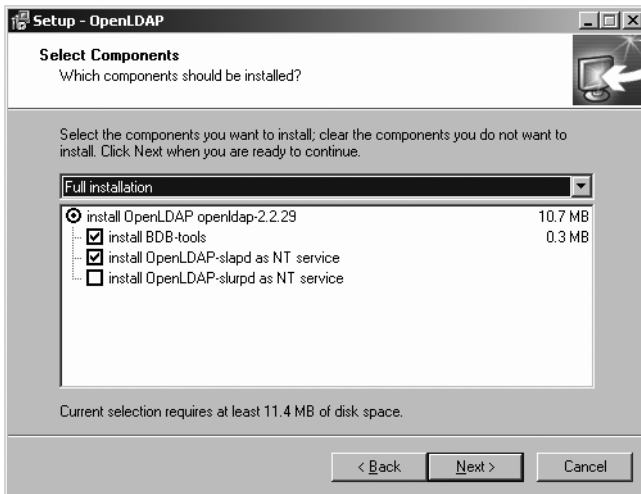

OpenLDAP Server Configuration

The main OpenLDAP configuration file, `slapd.conf`, has to be customized before launching the server. The modifications to the configuration file will do the following:

- ◆ Specify the Unicode data directory. The default is `./ucdata`.
- ◆ Choose the required LDAP schemas. The core schema is mandatory.
- ◆ Configure the path for the OpenLDAP `pid` and `args` start up files. The first contains the server pid, the second includes command line arguments.
- ◆ Choose the database type. The default is `bdb` (Berkeley DB).
- ◆ Specify the server suffix. All entries in the directory will have this suffix, which represents the root of the directory tree. For example, with suffix `dc=aten,dc=com`, the fully qualified name of all entries in the database will end with `dc=aten,dc=com`.
- ◆ Define the name of the administrator entry for the server (`rootdn`), along with its password (`rootpw`). This is the server's super user. The `rootdn` name must match the suffix defined above. (Since all entry names must end with the defined suffix, and the `rootdn` is an entry.)

An example configuration file is provided in the figure, below:

```
ucdata-path ./ucdata
include ./schema/core.schema

pidfile ./run/slapd.pid
argsfile ./run/slapd.args

database bdb
suffix "dc=aten,dc=com"
rootdn "cn=Manager,dc=aten,dc=com"
rootpw secret
directory ./data
```

Starting the OpenLDAP Server

To start the OpenLDAP Server, run **slapd** (the OpenLDAP Server executable file) from the command line. slapd supports a number of command line options, the most important option is the **d** switch that triggers debug information. For example, a command of:

```
slapd -d 256
```

would start OpenLDAP with a debug level of 256, as shown in the following screenshot:

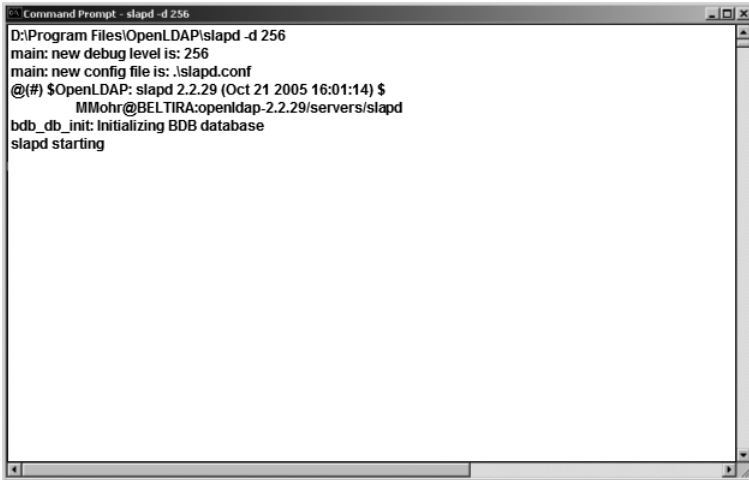

```
Command Prompt - slapd -d 256
D:\Program Files\OpenLDAP\slapd -d 256
main: new debug level is: 256
main: new config file is: .slapd.conf
@(#) $OpenLDAP: slapd 2.2.29 (Oct 21 2005 16:01:14) $
MMohr@BELTIRA:openldap-2.2.29/servers/slapd
bdb_db_init: Initializing BDB database
slapd starting
```

Note: For details about slapd options and their meanings, refer to the OpenLDAP documentation.

Customizing the OpenLDAP Schema

The schema that slapd uses may be extended to support additional syntaxes, matching rules, attribute types, and object classes.

In the case of the KN9108 / KN9116, the *User Class* and the *User Profile* attribute are extended to define a new schema (e.g. kn2116.schema). The extended schema file used to authenticate and authorize users logging in to the KN9108 / KN9116 is shown in the figure, below:

```
#####  
##   Copyright (C) 2008-2009 ATEN CANADA TECHNOLOGIES INC.  
##   Summary: Define the LDAP schema used in KN9116  
#####  
#  
#   ATEN OID:={1.3.6.1.4.1.2131*7}  
#  
attributetype ( 1.3.6.1.4.1.21317.1.1.4.2.5  
                NAME 'KVM2116-userProfile'  
                EQUALITY caseIgnoreMatch  
                SUBSTR caseIgnoreSubstringsMatch  
                SYNTAX 1.3.6.1.4.1.1466.115.121.1.15  
                SINGLE-VALUE )  
  
objectclass ( 1.3.6.1.4.1.21317.1.1.4.1.5  
              NAME 'kn2116user'  
              SUP organizationalPerson  
              STRUCTURAL  
              MAY (iKVM2116-userProfile $ userCertificate ))
```

LDAP DIT Design and LDIF File

LDAP Data Structure

An LDAP Directory stores information in a tree structure known as the Directory Information Tree (DIT). The nodes in the tree are directory entries, and each entry contains information in attribute-value form. An example of the LDAP directory tree for the KN9108 / KN9116 is shown in the figure, below:

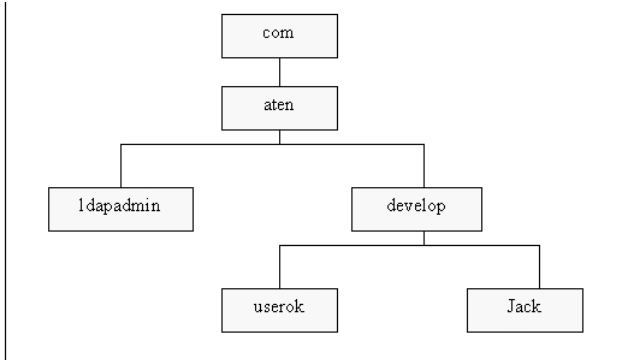

(Continues on next page.)

(Continued from previous page.)

DIT Creation

The LDAP Data Interchange Format (LDIF) is used to represent LDAP entries in a simple text format (please refer to RFC 2849). The figure below illustrates an LDIF file that creates the DIT for the KN9108 / KN9116 directory tree (shown in the figure, above).

```
dn: dc=aten,dc=com
objectclass: top
objectclass: dcObject
objectclass: organization

dn: cn=ldapadmin,dc=aten,dc=com
objectclass: top
objectclass: person
objectclass: organizationalPerson
cn: ldapadmin
sn: ldapadmin
userPassword: password

dn: ou=develop,dc=aten,dc=com
objectclass: top
objectclass: organizationalUnit
ou: develop

dn: cn=user-ldap,ou=develop,dc=aten,dc=com
objectclass: top
objectclass: person
objectclass: organizationalPerson
objectclass: kn2116user
cn: user-ldap
sn: user-ldap
iKV M2116-userProfile: w,j,c
userPassword: password
```

Note: The example above shows the permissions for a Type 1 Schema. For a Type 2 Schema, change the permissions line to su/user. (Where *user* represents the Username of a KN9108 / KN9116 user whose permissions reflect the permissions you want **steve** to have.)

(Continues on next page.)

(Continued from previous page.)

Using the New Schema

To use the new schema, do the following:

1. Save the new schema file (e.g., kn2116.schema) in the /OpenLDAP/schema/ directory.
2. Add the new schema to the slapd.conf file, as shown in the figure, below:

```
ucldata-path    ./ucldata
include         ./schema/core.schema
include         ./schema/cosine.schema
include         ./schema/inetorgperson.schema
include         ./schema/openldap.schema
include         ./schema/kn2116.schema

#Define global ACLs to disable default read access.
access to dn:children="cu=develop,dc=aten,dc=com"
    by dn="cn=ldapadmin,dc=aten,dc=com" write
    by self read
    by anonymous auth
    by * none

pidfile         ./run/slapd.pid
argsfile        ./run/slapd.args
#####
#BDB database definitions
#####
database        bdb
suffix          "dc=aten,dc=com"
rootdn         "cn=ldapadmin,dc=aten,dc=com"
rootpw         password
directory      ./data
#Indices to maintain
index objectClass eq
```

3. Restart the LDAP server.
4. Write the LDIF file and create the database entries in init.ldif with the *ldapadd* command, as shown in the following example:

```
ldapadd -f init.ldif -x -D "cn=Manager,dc=aten,dc=com"
-w secret
```

Safety Instructions

General

- ◆ Read all of these instructions. Save them for future reference.
- ◆ Follow all warnings and instructions marked on the device.
- ◆ Do not place the device on any unstable surface (cart, stand, table, etc.). If the device falls, serious damage will result.
- ◆ Do not use the device near water.
- ◆ Do not place the device near, or over, radiators or heat registers.
- ◆ The device cabinet is provided with slots and openings to allow for adequate ventilation. To ensure reliable operation, and to protect against overheating, these openings must never be blocked or covered.
- ◆ The device should never be placed on a soft surface (bed, sofa, rug, etc.) as this will block its ventilation openings. Likewise, the device should not be placed in a built in enclosure unless adequate ventilation has been provided.
- ◆ Never spill liquid of any kind on the device.
- ◆ Unplug the device from the wall outlet before cleaning. Do not use liquid or aerosol cleaners. Use a damp cloth for cleaning.
- ◆ The device should be operated from the type of power source indicated on the marking label. If you are not sure of the type of power available, consult your dealer or local power company.
- ◆ The device is designed for IT power distribution systems with 230V phase-to-phase voltage.
- ◆ To prevent damage to your installation it is important that all devices are properly grounded.
- ◆ The device is equipped with a 3-wire grounding type plug. This is a safety feature. If you are unable to insert the plug into the outlet, contact your electrician to replace your obsolete outlet. Do not attempt to defeat the purpose of the grounding-type plug. Always follow your local/national wiring codes.
- ◆ Do not allow anything to rest on the power cord or cables. Route the power cord and cables so that they cannot be stepped on or tripped over.

- ◆ If an extension cord is used with this device make sure that the total of the ampere ratings of all products used on this cord does not exceed the extension cord ampere rating. Make sure that the total of all products plugged into the wall outlet does not exceed 15 amperes.
- ◆ To help protect your system from sudden, transient increases and decreases in electrical power, use a surge suppressor, line conditioner, or uninterruptible power supply (UPS).
- ◆ Position system cables and power cables carefully; Be sure that nothing rests on any cables.
- ◆ Never push objects of any kind into or through cabinet slots. They may touch dangerous voltage points or short out parts resulting in a risk of fire or electrical shock.
- ◆ Do not attempt to service the device yourself. Refer all servicing to qualified service personnel.
- ◆ If the following conditions occur, unplug the device from the wall outlet and bring it to qualified service personnel for repair.
 - ◆ The power cord or plug has become damaged or frayed.
 - ◆ Liquid has been spilled into the device.
 - ◆ The device has been exposed to rain or water.
 - ◆ The device has been dropped, or the cabinet has been damaged.
 - ◆ The device exhibits a distinct change in performance, indicating a need for service.
 - ◆ The device does not operate normally when the operating instructions are followed.
- ◆ Only adjust those controls that are covered in the operating instructions. Improper adjustment of other controls may result in damage that will require extensive work by a qualified technician to repair.
- ◆ Do not connect the RJ-11 connector marked “UPGRADE” to a public telecommunication network.

Rack Mounting

- ◆ Before working on the rack, make sure that the stabilizers are secured to the rack, extended to the floor, and that the full weight of the rack rests on the floor. Install front and side stabilizers on a single rack or front stabilizers for joined multiple racks before working on the rack.
- ◆ Always load the rack from the bottom up, and load the heaviest item in the rack first.
- ◆ Make sure that the rack is level and stable before extending a device from the rack.
- ◆ Use caution when pressing the device rail release latches and sliding a device into or out of a rack; the slide rails can pinch your fingers.
- ◆ After a device is inserted into the rack, carefully extend the rail into a locking position, and then slide the device into the rack.
- ◆ Do not overload the AC supply branch circuit that provides power to the rack. The total rack load should not exceed 80 percent of the branch circuit rating.
- ◆ Make sure that all equipment used on the rack – including power strips and other electrical connectors – is properly grounded.
- ◆ Ensure that proper airflow is provided to devices in the rack.
- ◆ Ensure that the operating ambient temperature of the rack environment does not exceed the maximum ambient temperature specified for the equipment by the manufacturer
- ◆ Do not step on or stand on any device when servicing other devices in a rack.

Technical Support

Technical support is available both by email and online (with a browser over the web):

International

Email Support		support@aten.com
Online Support	Technical Support	http://support.aten.com
	Troubleshooting Documentation Software Updates	http://www.aten.com
Telephone Support		886-2-8692-6959

North America

Email Support		ATEN TECH	support@aten-usa.com
		ATEN NJ	sales@aten.com
Online Support	Technical Support	ATEN TECH	http://www.aten-usa.com/support
		ATEN NJ	http://support.aten.com
	Troubleshooting Documentation Software Updates	ATEN TECH	http://www.aten-usa.com
		ATEN NJ	http://www.aten.com
Telephone Support		ATEN TECH	1-888-999-ATEN
		ATEN NJ	1-732-356-1703

When you contact us, please have the following information ready beforehand:

- ◆ Product model number, serial number, and date of purchase.
- ◆ Your computer configuration, including operating system, revision level, expansion cards, and software.
- ◆ Any error messages displayed at the time the error occurred.
- ◆ The sequence of operations that led up to the error.
- ◆ Any other information you feel may be of help.

Troubleshooting

Administration

Symptom	Possible Cause	Action
After upgrading firmware, the KN9108 / KN9116 still appears to be using the old firmware version.	Your Internet browser is displaying cached web pages and has not fetched new versions of the KN9108 / KN9116 web pages.	Delete all temporary Internet files and cookies, close the Internet browser, and then open a new instance of the browser.

General Operation

Problem	Resolution
Erratic Operation	Press and hold the Reset Switch (see page 8) for longer than three seconds.
Mouse and/or keyboard not responding due to improper mouse and/or keyboard reset.	Unplug the cable(s) from the console port(s), then plug it back in again.
Sudden loss of network connection due to local reset of KN9108 / KN9116.	Close your KN9108 / KN9116 connection. Wait approximately 30 seconds, and log in again.
Mouse Pointer Confusion	If you find the display of two mouse pointers (local and remote) to be confusing or annoying, you can use the <i>Toggle Mouse Display</i> function to shrink the non-functioning pointer. .

The Java Client

For mouse synchronization problems, see *The On-Screen Keyboard*, page 89.

For connection and operation problems, see the table below:

Problem	Resolution
Java Client won't connect to the KN9108 / KN9116.	<ol style="list-style-type: none"> 1. The latest Java version must be installed on your client computer. 2. Check if you need to specify the program port as well as the IP address. See <i>Java Client AP Login</i>, page 23, for details. 3. Close the Java Client, reopen it, and try again.
Pressing the Windows Menu key has no effect.	Java doesn't support the Windows Menu key.
Java Client performance deteriorates.	Exit the program and start again.
National language characters do not appear.	When entering national language characters, if your local keyboard is set to a non-English national language layout, you must set the remote computer's keyboard layout to English.

The Log Server

Problem	Resolution
The Log Server program does not run.	<p>The Log Server requires the Microsoft Jet OLEDB 4.0 driver in order to access the database.</p> <p>This driver is automatically installed with Windows ME, 2000, and XP.</p> <p>For Windows 98 and NT you will have to go to the Microsoft download site:</p> <p style="padding-left: 40px;">http://www.microsoft.com/data/download.htm</p> <p>to retrieve the driver file:</p> <p style="padding-left: 40px;">MDAC 2.7 RTM Refresh (2.70.9001.0)</p> <p>Since this driver is used in Windows Office Suite, an alternate method of obtaining it is to install Windows Office Suite. Once the driver file or Suite has been installed, the Log Server will run.</p>

Panel Array Mode

Problem	Resolution
Low resolution video in Panel Array Mode.	Increase the number of panels that are displayed.
Some users only receive a partial image when multiple remote users are logged in concurrently.	The first user to invoke Panel Array Mode should set it to display a minimum of four panels.

The WinClient ActiveX Viewer or AP

Problem	Resolution
WinClient ActiveX Viewer won't connect to the KN9108 / KN9116.	DirectX 8.0 or higher must be installed on your computer.
Remote mouse pointer is out of sync.	<ol style="list-style-type: none"> 1. Use the <i>AutoSync</i> feature (see <i>Video Settings</i>, page 82), to sync the local and remote monitors. 2. If that doesn't resolve the problem, use the <i>Adjust Mouse</i> feature (see <i>The On-Screen Keyboard</i>, page 89) to bring them back in sync. 3. If the two methods described above fail to resolve the problem, use the <i>Toggle Mouse Display</i> function. 4. Set mouse acceleration to zero. See <i>Additional Mouse Synchronization Procedures</i>, page 131, for details.
Part of remote window is off my monitor.	If <i>Keep Screen Size</i> is not enabled, use the <i>AutoSync</i> feature (see <i>Video Settings</i> , page 82) to synchronize the local and remote monitors. If it is enabled, see the discussion on page 92.
The remote screen display is rotated 90 degrees.	Enable <i>Keep Screen Size</i> . See the discussion on page 92 for details.
I cannot run Net Meeting when the WinClient ActiveX Viewer is running.	Enable <i>Keep Screen Size</i> . (See the discussion on page 92 for details.)

Sun Systems

Problem	Resolution
Video display problems with HDB-15 interface systems (e.g. Sun Blade 1000 servers).	<p>The display resolution should be set to 1024 x 768.</p> <p>Under Text Mode:</p> <ol style="list-style-type: none"> Go to OK mode and issue the following commands: <pre>setenv output-device screen:r1024x768x60 reset-all</pre> <p>Under XWindow:</p> <ol style="list-style-type: none"> Open a console and issue the following command: <pre>m64config -res 1024x768x60</pre> Log out. Log in.
Video display problems with 13W3 interface systems (e.g. Sun Ultra servers).*	<p>The display resolution should be set to 1024 x 768.</p> <p>Under Text Mode:</p> <ol style="list-style-type: none"> Go to OK mode and issue the following commands: <pre>setenv output-device screen:r1024x768x60 reset-all</pre> <p>Under XWindow:</p> <ol style="list-style-type: none"> Open a console and issue the following command: <pre>ffbconfig -res 1024x768x60</pre> Log out. Log in.

* These solutions work for most common Sun VGA cards. If using them fails to resolve the problem, consult the Sun VGA card's manual.

Mac Systems

Problem	Resolution
When I log in to the switch with my Safari browser, it hangs when I use the Snapshot feature.	<p>Force close Safari, then reopen it. Don't use the Snapshot feature in the future.</p> <p>To use the Snapshot feature with Safari, upgrade to Mac OS 10.4.11 and Safari 3.0.4.</p>

Additional Mouse Synchronization Procedures

If the mouse synchronization procedures mentioned in the manual fail to resolve mouse pointer problems for particular computers, try the following:

-
- Note:** 1. These procedures are to be performed on the computers attached to the KN9108 / KN9116's ports - not on the computer you are using to access the KN9108 / KN9116.
2. In order for the local and remote mice to synchronize, you must use the generic mouse driver supplied with the Windows operating system. If you have a third party driver installed - such as one supplied by the mouse manufacturer - you must remove it.
-

1. Windows 2000:

Set the mouse speed to the middle position; set the mouse acceleration to *None* (Control Panel → Mouse → Mouse Properties → Motion):

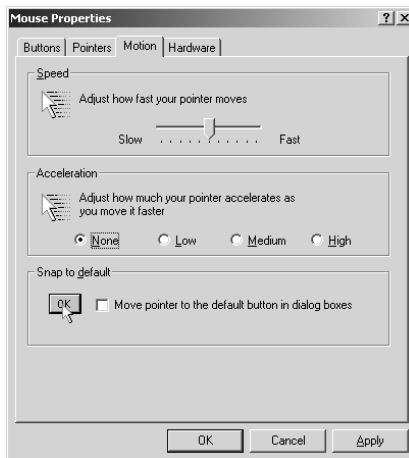

2. Windows XP / Windows Server 2003:

Set the mouse speed to the middle position; disable *Enhance Pointer Precision* (Control Panel → Printers and Other Hardware → Mouse → Pointer Options):

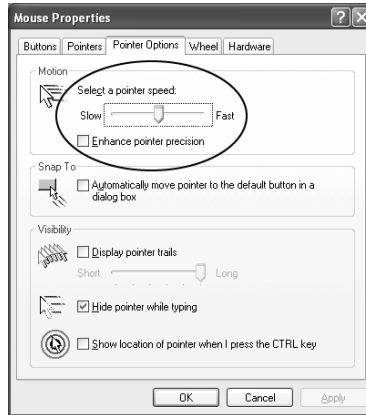

3. Windows ME / Windows 95:

Set the mouse speed to the middle position; disable mouse acceleration (click Advanced to get the dialog box for this).

4. Windows NT / Windows 98:

Set the mouse speed to the slowest position.

Sun / Linux

Open a terminal session and issue the following command:

```
Sun: xset m 1
```

```
Linux: xset m 0
```

or

```
xset m 1
```

(If one doesn't help, try the other.)

```
Linux using the Redhat AS3.0 mouse mode: xset m 1
```

Self-Signed Private Certificates

If you wish to create your own self-signed encryption key and certificate, a free utility – `openssl.exe` – is available for download over the web at www.openssl.org. To create your private key and certificate do the following:

1. Go to the directory where you downloaded and extracted *openssl.exe* to.
2. Run `openssl.exe` with the following parameters:

```
openssl req -new -newkey rsa:1024 -days 3653 -nodes -x509
-keyout CA.key -out CA.cer -config openssl.cnf
```

Note: 1. The command should be entered all on one line (i.e., do not press [Enter] until all the parameters have been keyed in).

2. If there are spaces in the input, surround the entry in quotes (e.g., “ATEN International”).
-

To avoid having to input information during key generation the following additional parameters can be used:

```
/C /ST /L /O /OU /CN /emailAddress.
```

Examples

```
openssl req -new -newkey rsa:1024 -days 3653 -nodes -x509
-keyout CA.key -out CA.cer -config openssl.cnf -subj
/C=yourcountry/ST=yourstateorprovince/L=yourlocationor
city/O=yourorganization/OU=yourorganizationalunit/
CN=yourcommonname/emailAddress=name@yourcompany.com
```

```
openssl req -new -newkey rsa:1024 -days 3653 -nodes -x509
-keyout CA.key -out CA.cer -config openssl.cnf -subj
/C=CA/ST=BC/L=Richmond/O="ATEN International"/OU=ATEN
/CN=ATEN/emailAddress=eservice@aten.com.tw
```

Importing the Files

After the `openssl.exe` program completes, two files – `CA.key` (the private key) and `CA.cer` (the self-signed SSL certificate) – are created in the directory that you ran the program from. These are the files that you upload in the *Private Certificate* panel of the Maintenance page (see page 59).

Administrator Login Failure

If you are unable to perform an Administrator login (because the Username and Password information has become corrupted, or you have forgotten it, for example), there is a procedure you can use to clear the login information.

Note: Performing this procedure also returns all settings to their defaults.

To clear the login information (and return all settings to their defaults), do the following:

1. Power off the KN9108 / KN9116 and remove its housing.
2. Using a jumper cap, short the jumper on the mainboard labeled J8.

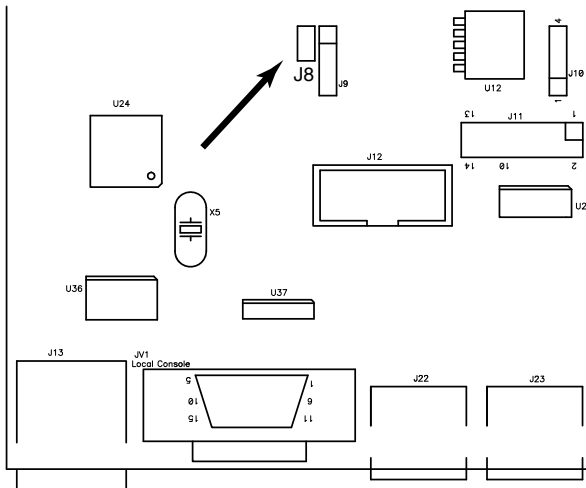

3. Power on the switch.
4. When the front panel LEDs flash, power off the switch.
5. Remove the jumper cap from J8.
6. Close the housing and power on the KN9108 / KN9116.

After powering on the unit, you can use the default Username and Password (see *The Local Console*, page 25), to log in.

Specifications

Function		KN9108	KN9116	
Computer Connections	Direct	8	16	
	Maximum	64 (via cascade)	128 (via cascade)	
Port Selection		OSD; Hotkey; Pushbuttons		
Connectors	Console Port	Keyboard	1 x 6-pin Mini-DIN Female (Purple)	
		Video	1 x HDB-15 Female (Blue)	
		Mouse	1 x 6-pin Mini-DIN Female (Green)	
	KVM Port		8 x SPHD-17 F (Yellow)	16 x SPHD-17 F (Yellow)
	Power		1 x 3-prong AC socket	
	LAN		1 x RJ-45 Female	
	PON		1 x DB-9 Male (Black)	
Switches	Reset	1 x Semi-recessed Pushbutton		
	Power	1 x Rocker		
	Port Selection	2 x Pushbutton		
LEDs	On Line	8 (Green)	16 (Green)	
	Selected	8 (Orange)	16 (Orange)	
	Power	1 (Blue)		
	Link	1 (Green)		
	10 / 100Mbps	1 (Orange / Green)		
Emulation	Keyboard/Mouse	PS/2		
Video		1600 x 1200 @ 60Hz; DDC2B		
Scan Interval		1–255 secs		
I/P Rating		100V–240V; 50/60Hz; 250mA		
Power Consumption		120V/60Hz/12W; 230V/50Hz/12W		
Environment	Operating Temp.	0–40° C		
	Storage Temp.	-20–60° C		
	Humidity	0–80% RH		
Physical Properties	Housing	Metal		
	Weight	4.00 kg	4.20 kg	
	Dimensions L x W x H	43.72 x 26.00 x 4.40 cm (19" 1U)		

Compatible Cascade Switches

The following Altusen and ATEN KVM switches can be cascaded from the KN9108 / KN9116. Some KVM Over the Net™ features may not be supported, depending on the functionality of the cascaded switch:

- ◆ CS88A
- ◆ CS9134
- ◆ CS9138
- ◆ KH98

OSD Factory Default Settings

The factory default settings are as follows:

Setting	Default
OSD Hotkey	[Scroll Lock] [Scroll Lock]
Port ID Display	Port Number + Name
Port ID Display Duration	5 Seconds
Scan / Skip Mode	All
Scan Duration	10 Seconds
Screen Blanker	0 Minutes (disabled)
Beeper	On
Accessible Ports	F (Full) For all Users on all Ports

About SPHD Connectors



This product uses SPHD connectors for its KVM and/or Console ports. We have specifically modified the shape of these connectors so that only KVM cables that we have designed to work with this product can be connected.

Trusted Certificates

Overview

When you try to log in to the device from your browser, a Security Alert message appears to inform you that the device's certificate is not trusted, and asks if you want to proceed.



The certificate can be trusted, but the alert is triggered because the certificate's name is not found on Microsoft list of Trusted Authorities. You have two options: 1) you can ignore the warning and click **Yes** to go on; or 2) you can install the certificate and have it be recognized as trusted.

- ◆ If you are working on a computer at another location, accept the certificate for just this session by clicking **Yes**.
- ◆ If you are working at your own computer, install the certificate on your computer (see below for details). After the certificate is installed, it will be recognized as trusted.

Installing the Certificate

To install the certificate, do the following:

1. In the *Security Alert* dialog box, click **View Certificate**. The *Certificate Information* dialog box appears:



Note: There is a red and white X logo over the certificate to indicate that it is not trusted.

2. Click **Install Certificate**.
3. Follow the Installation Wizard to complete the installation. Unless you have a specific reason to choose otherwise, accept the default options.
4. When the Wizard presents a caution screen:

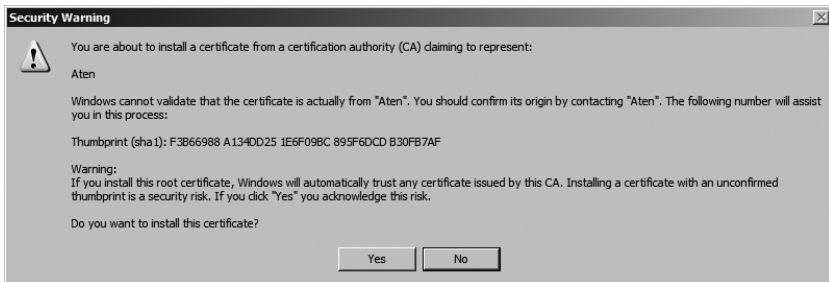

Click **Yes**.

- Next, click **Finish** to complete the installation; then click **OK** to close the dialog box.

Certificate Trusted

The certificate is now trusted:



When you click *View Certificate*, you can see that the red and white **X** logo is no longer present – further indication that the certificate is trusted:



Mismatch Considerations

If the site name or IP address used for generating the certificate no longer matches the current address of the switch a mismatch warning occurs:



You can click **Yes** to go on, or you can disable mismatch checking.

To disable mismatch checking, do the following:

1. After the page you are logging in to comes up open the browser's Tools menu; Select *Internet Options* → *Advanced*.
2. Scroll to the bottom of the list and uncheck *Warn about trusted certificates*:

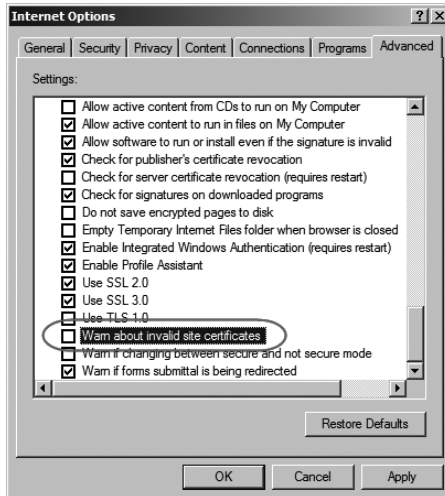

3. Click **OK**. The next time you run the browser the change will be in effect.

Limited Warranty

ATEN warrants this product against defects in material or workmanship for a period of one (1) year from the date of purchase. If this product proves to be defective, contact ATEN's support department for repair or replacement of your unit. ATEN will not issue a refund. Return requests can not be processed without the original proof of purchase.

When returning the product, you must ship the product in its original packaging or packaging that gives an equal degree of protection. Include your proof of purchase in the packaging and the RMA number clearly marked on the outside of the package.

This warranty becomes invalid if the factory-supplied serial number has been removed or altered on the product.

This warranty does not cover cosmetic damage or damage due to acts of God, accident, misuse, abuse, negligence or modification of any part of the product. This warranty does not cover damage due to improper operation or maintenance, connection to improper equipment, or attempted repair by anyone other than ATEN. This warranty does not cover products sold AS IS or WITH FAULTS.

IN NO EVENT SHALL ATEN'S LIABILITY EXCEED THE PRICE PAID FOR THE PRODUCT. FURTHER, ATEN SHALL NOT BE RESPONSIBLE FOR DIRECT, INDIRECT, SPECIAL, INCIDENTAL OR CONSEQUENTIAL DAMAGES RESULTING FROM THE USE OF THE PRODUCT, ITS ACCOMPANYING SOFTWARE, OR ITS DOCUMENTATION. ATEN SHALL NOT IN ANY WAY BE RESPONSIBLE FOR, WITHOUT LIMITATION, LOSS OF DATA, LOSS OF PROFITS, DOWNTIME, GOODWILL, DAMAGE OR REPLACEMENT OF EQUIPMENT OR PROPERTY, AND ANY EXPENSES FROM RECOVERY, PROGRAMMING, AND REPRODUCTION OF ANY PROGRAM OR DATA.

ATEN makes no warranty or representation, expressed, implied, or statutory with respect to its products, contents or use of this documentation and all accompanying software, and specifically disclaims its quality, performance, merchantability, or fitness for any particular purpose.

ATEN reserves the right to revise or update its product, software or documentation without obligation to notify any individual or entity of such revisions, or update.

For details about extended warranties, please contact one of our dedicated value added resellers.

This Page Intentionally Left Blank

A

- Administration, 25
- Administration Page, 35
 - Customization, 49
 - Date/Time, 53
 - General, 35
 - Network, 41
 - Security, 47
 - User Management, 36
- Administrator Login Failure, 134
- AP Operation
 - WinClient, 17
 - Java Client, 23
- Auto Scanning, 67
 - Invoking Auto Scan, 67
 - Multiuser Operation, 71
 - Pausing Auto Scan, 68
 - Scan Duration, 33, 95
 - Setting the Scan Interval, 67

B

- Beeper, 33, 95
- Browser
 - General Dialog Box, 56
 - Operation, 55

C

- CC Management, 46
- Clear Name List, 52
- Compatible Cascade Switches, 136
- Configuration Page
 - Windows Client, 32, 94
- Control Panel
 - Windows Client, 72
- Corrupt Password, 134
- Customization Settings, 49

D

- Date/Time Settings, 53

F

- Factory Default Settings, 136
- Features, 3
- Firmware, Upgrading, 58
- Forgotten Password, 134

H

- Hot Plugging, 14
- Hotkey
 - OSD, 33, 95
- Hotkey Operation, 67
 - Auto Scanning, 67

I

- Installation, 13
- Invalid login, 16
- IP Address, 35, 56
 - Configuring, 41

J

- Java Client, 2, 23
 - Activating the OSD, 62
 - AP Installation, 23
 - AP Login, 24
 - AP Operation, 24
 - Troubleshooting, 128
- Java Client AP
 - Logging in, 23

K

- Keyboard
 - On-Screen, 89

L

- LDAP Server Configuration, 107
- List Function, 28
- Local Console, 25
 - Administration Page, 35
 - Log Page, 54
 - Main Page, 27
- Log File, 97
- Log Page, 54
- Log Server
 - Configure, 101
 - Events, 102
 - Installation, 99
 - KN9108 / KN9116 Main Screen, 105
 - Main Screen, 100
 - Maintenance, 104
 - Menu Bar, 101
 - Options, 104
 - Search, 102
 - Settings, 40
 - Starting Up, 100
- Logging in
 - Browser, 16
 - Java Client AP, 23
 - Local console, 15
 - WinClient AP, 17
- Login
 - Failure, 49
 - Invalid login, 16

M

- Macros
 - Search, 77
- Main Page
 - Local Console, 27
 - Windows Client, 63
- Main Webpage, 16, 55
- Message Board

- Windows Client, 86
- Mouse Synchronization, 93
- Multiuser Operation, 49, 71

N

- Naming ports, 30
- Network, 41
- Network Transfer Rate, 41

O

- Online
 - Registration, iii
- On-Screen Keyboard, 89
- OpenLDAP
 - Server Configuration, 117
 - Server Installation, 116
- OSD
 - Activating in Java, 62
 - Activating in Windows, 61
 - Administration Page, 35, 63
 - Configuration Page, 32, 94
 - Factory Default Settings, 136
 - Hotkey, 33, 95
 - Log Page, 54
 - Main Page, 27, 63
 - Toolbar, 65
- Overview, 1

P

- Panel Array Mode
 - Multiuser Operation, 71
 - Windows Client, 69
- Port ID
 - Display Mode, 33, 95
 - Numbering, 14
- Port Names, 30
- Port names, 30
- Port operation
 - Windows Client, 65

Port Selection, 14
Powering Off and Restarting, 14
Private Certificates, 133

Q

Quick View Ports, 27

R

Rack Mounting, 12
RADIUS, 42
refresh screen, 84
Requirements
 Operating Systems, 6
 OS Support, 6
Reset on exit, 52, 56
Reset Values, 52
RoHS, ii

S

Safety Instructions
 General, 123
 Rack Mounting, 125
Save Settings
 Reset on exit, 52
Scan
 Duration, 33, 95
 Select, 33, 95
Screen Blanker, 33, 95
screen, refresh, 84
Search
 Macros, 77
Security Settings, 47
Self-signed certificates, 133
Setting the Auto Scan Interval, 67
Share Mode, 50
SJ/T 11364-2006, ii
Skip Mode, 68
Specifications, 135
SPHD Connectors, 136

Stealth Mode, 49
System Requirements, 4

T

Technical Support, 126
Telephone support, iii
Toolbar
 OSD, 65
 Panel Array Mode (Windows), 69
Troubleshooting
 Administration, 127
 General operation, 127
 Java Client, 128
 Log Server, 128
 Login Failure, 134
 Mac Systems, 130
 Panel Array Mode, 129
 Sun Systems, 130
 Windows Client, 129
Trusted Certificates, 137

U

Upgrading the Firmware, 58
User Management, 36
User Notice, iii

V

Video requirements, 5
Video Settings, 82

W

Webpage
 Buttons, 60
 Icons, 57
 Layout, 56
WinClient AP
 Logging in, 17
Windows AP
 Connection Screen, 19

Windows Client, 2	Control Panel, 72
Activating the OSD, 61	Message Board, 86
AP File Menu, 20	OSD Toolbar, 65
AP Installation, 17	Troubleshooting, 129
AP Login, 21	Windows client, 63
AP Operation, 22	