



PE5108-ATB / PE5208-ATB
PE6108-ATB / PE6208-ATB
PE8108-ATB / PE8208-ATB
8-Outlet 1U Metered eco PDU
User Manual

Compliance Statements

FEDERAL COMMUNICATIONS COMMISSION INTERFERENCE STATEMENT

This equipment has been tested and found to comply with the limits for a Class A digital device, pursuant to Part 15 of the FCC Rules. These limits are designed to provide reasonable protection against harmful interference when the equipment is operated in a commercial environment. This equipment generates, uses, and can radiate radio frequency energy and, if not installed and used in accordance with the instruction manual, may cause harmful interference to radio communications. Operation of this equipment in a residential area is likely to cause harmful interference in which case the user will be required to correct the interference at his own expense.

The device complies with Part 15 of the FCC Rules. Operation is subject to the following two conditions: (1) this device may not cause harmful interference, and (2) this device must accept any interference received, including interference that may cause undesired operation.

FCC Caution

Any changes or modifications not expressly approved by the party responsible for compliance could void the user's authority to operate this equipment.

Warning

Operation of this equipment in a residential environment could cause radio interference.

Achtung

Der Gebrauch dieses Geräts in Wohnumgebung kann Funkstörungen verursachen.



Note: The UL Listed compatible models are:

PE5108A, PE5108B, PE5208A, PE5208B, PE6108A, PE6108B, PE6208A, PE6208B, PE8108A, PE8108B, PE8208A, and PE8208B.

KCC Statement

유선 제품용 / A 급 기기 (업무용 방송 통신 기기)
이 기기는 업무용 (A 급) 전자파적합기기로서 판매자 또는 사용자는 이
점을 주의하시기 바라며, 가정 외의 지역에서 사용하는 것을 목적으로
합니다.

Industry Canada Statement

This Class A digital apparatus complies with Canadian ICES-003.

CAN ICES-003 (A) / NMB-003 (A)**VCCI Statement**

この装置は、クラスA機器です。この装置を住宅環境で使用すると電波妨害
を引き起こすことがあります。この場合には使用者が適切な対策を講ずるよう
要求されることがあります。

VCCI - A**RoHS**

This product is RoHS compliant.

PE Device Safety Notice



- ◆ Set the maximum permissible breaker protection in the building circuitry to the current rating specified on the rating plate. Observe all national regulations and safety codes as well as deviations for breakers.
- ◆ Only connect the PE Device to a grounded power outlet or a grounded system!
- ◆ Make sure that the total current input of the connected systems does not exceed the current rating specified on the rating plate of the PE Device.
- ◆ There is a risk of explosion if the battery is replaced with an incorrect type. Dispose of used batteries according to the relevant instructions.

Consignes de sécurité relatives à l'unité PE



- ◆ Installez sur le circuit du bâtiment des disjoncteurs permettant d'assurer la protection maximale autorisée, en respectant le courant nominal spécifié sur la plaque signalétique. Veuillez respecter l'ensemble des réglementations nationales en vigueur et des codes de sécurité ainsi que les déviations recommandées pour les disjoncteurs.
- ◆ Ne connectez l'unité PE qu'à une prise de courant avec borne de terre ou à un système mis à la terre!
- ◆ Assurez-vous que le courant d'entrée total des systèmes connectés ne dépassas le courant nominal spécifié sur la plaque signalétique de l'unité PE.
- ◆ Il existe un risque d'explosion si la batterie est remplacée par une batterie de type incorrect. Jetez les batteries usagées en respectant les instructions adéquates.

User Information

Online Registration

Be sure to register your product at our online support center:

International	http://eservice.aten.com
---------------	---

Telephone Support

For telephone support, call this number:

International	886-2-8692-6959
China	86-400-810-0-810
Japan	81-3-5615-5811
Korea	82-2-467-6789
North America	1-888-999-ATEN ext 4988 1-949-428-1111

User Notice

All information, documentation, and specifications contained in this manual are subject to change without prior notification by the manufacturer. The manufacturer makes no representations or warranties, either expressed or implied, with respect to the contents hereof and specifically disclaims any warranties as to merchantability or fitness for any particular purpose. Any of the manufacturer's software described in this manual is sold or licensed *as is*. Should the programs prove defective following their purchase, the buyer (and not the manufacturer, its distributor, or its dealer), assumes the entire cost of all necessary servicing, repair and any incidental or consequential damages resulting from any defect in the software.

The manufacturer of this system is not responsible for any radio and/or TV interference caused by unauthorized modifications to this device. It is the responsibility of the user to correct such interference.

The manufacturer is not responsible for any damage incurred in the operation of this system if the correct operational voltage setting was not selected prior to operation. PLEASE VERIFY THAT THE VOLTAGE SETTING IS CORRECT BEFORE USE.

Product Information

For information about all ATEN products and how they can help you connect without limits, visit ATEN on the Web or contact an ATEN Authorized Reseller. Visit ATEN on the Web for a list of locations and telephone numbers:

International	http://www.aten.com
North America	http://www.aten-usa.com

Package Contents

Check to make sure that all the components are in working order. If you encounter any problem, please contact your dealer.

The eco PDU standard package consists of:

- ◆ 1 PE5108-ATB / PE5208-ATB / PE6108-ATB / PE6208-ATB / PE8108-ATB / PE8208-ATB Power Distribution Unit
- ◆ 1 power cord
- ◆ 1 mounting kit
- ◆ 1 user instructions*

* Features may have been added to the eco PDU since this manual was released. Please visit our website to download the most up-to-date version.

Contents

Compliance Statements	ii
Consignes de sécurité relatives à l'unité PE	iv
User Information	v
Online Registration	v
Telephone Support	v
User Notice	v
Product Information	vi
Package Contents	vi
Contents	vii
About This Manual	xi
Conventions	xii

Chapter 1. Introduction

Overview	1
PE Series eco PDU Comparison Chart	3
Features	4
Power Distribution	4
Remote Access	4
Operation	4
Management	5
Security	5
Features available only on firmware-upgraded models with -ATB part number	5
Requirements	6
Optional Accessories	7
Sensors	7
Cable Holders	7
Components	8
PE5108A Front View	8
PE5208A Front View	8
PE5108A / PE5208A Rear View	8
PE5108A / PE5208A Readout Section	9
PE5108B / PE5108G Front View	11
PE5208B / PE5208G Front View	11
PE5108B / PE5108G / PE5208B / PE5208G Rear View	11
PE5108B / PE5108G / PE5208B / PE5208G Readout Section ..	12
PE6108A / PE8108A Front View	14

PE6208A / PE8208A Front View	14
PE6108A / PE6208A / PE8108A / PE8208A Rear View	14
PE6108A / PE6208A / PE8108A / PE8208A Readout Section	15
PE6108B / PE6108G / PE8108B / PE8108G Front View	17
PE6208B / PE6208G / PE8208B / PE8208G Front View	17
PE6108B / PE6108G / PE6208B / PE6208G / PE8108B / PE8108G / PE8208B / PE8208G Rear View	17
PE6108B / PE6108G / PE6208B / PE6208G / PE8108B / PE8108G / PE8208B / PE8208G Readout Section	18
Chapter 2. Hardware Setup	
Before You Begin	21
Rack Mounting	21
Installation	22
Securing the Cables	23
Securing the Sensors	24
Chapter 3. Basic Operation and First-Time Setup	
Operation Methods	25
Browser	25
eco DC	25
SNMP	25
First-Time Setup	26
Network Configuration	27
Changing the Administrator Login	28
Moving On	28
Chapter 4. Browser Operation	
Logging In	29
The eco PDU Main Page	30
Page Components	31
Energy	32
Connections	32
Configuration	35
Heartbeat	41
Autoping	45
User	48
Administrator Information	49
User Information	49
Log	51

The System Log Event List	51
Notification Settings	52
Setup	54
Device Configuration.....	54
Date/Time	61
Security	63
Login Failures.....	63
Working Mode	63
IPInstaller Setting	64
Session Timeout	64
Account Policy.....	64
IP Filter / Mac Filter.....	65
Authentication & Authorization	68
Private Certificate	70
Rules	72
Scheduler	74
Mail Control	76
PDU	79
Upgrade Main Firmware.....	79
Backup/Restore	81
Chapter 5.Appendix	
Safety Instructions	83
General	83
Consignes de sécurité	86
Général	86
Rack Mounting	89
The eco PDU's Main Power Cord	89
Securing the Power Cables	89
Montage sur bâti	90
Le cordon d'alimentation principale de l'unité d'alimentation éco	90
Fixation des câbles d'alimentation	90
Technical Support	92
International	92
North America	92
IP Address Determination	93
Specifications	95
PE5108A / PE5108B / PE5108G	95

PE5208A / PE5208B / PE5208G	97
PE6108A / PE6108B / PE6108G	99
PE6208A / PE6208B / PE6208G	101
PE8108A / PE8108B / PE8108G	103
PE8208A / PE8208B / PE8208G	105
Administrator Login Failure	107
ATEN Warranty Policy	108

About This Manual

This user manual is provided to help you get the most out of your eco PDU. It covers all aspects of the power distribution unit, including installation, configuration, and operation.

The eco PDU models covered in this manual include:

Model	
PE5108	15A/10A 8-Outlet 1U Metered eco PDU
PE5208	20A/16A 8-Outlet 1U Metered eco PDU
PE6108	15A/10A 8-Outlet 1U Metered & Switched eco PDU
PE6208	20A/16A 8-Outlet 1U Metered & Switched eco PDU
PE8108	15A/10A 8-Outlet 1U Outlet-Metered & Switched eco PDU
PE8208	20A/16A 8-Outlet 1U Outlet-Metered & Switched eco PDU

An overview of the information found in the manual is provided below.

Chapter 1, Introduction, introduces the eco PDU, its purpose, features, and benefits, with its front and back panel components described.

Chapter 2, Hardware Setup, provides step-by-step instructions for setting up the eco PDU.

Chapter 3, Basic Operation and First-time Setup, explains the basic operations of the eco PDU, and the necessary configurations for first-time setup.

Chapter 4, Browser Operation, explains how to log into the eco PDU remotely from a web browser, and the various functions it provides.

Appendix, provides specifications and other technical information regarding the eco PDU.

Note:

- ◆ Read this manual thoroughly and follow the installation and operation procedures carefully to prevent any damage to the unit and/or connected devices.
 - ◆ The product may be updated, with features and functions added, improved, or removed since the release of this manual. For an up-to-date user manual, visit <http://www.aten.com/global/en/>.
-

Conventions

This manual uses the following conventions:

- | | |
|---|--|
| Monospaced | Indicates text that you should key in. |
| [] | Indicates keys you should press. For example, [Enter] means to press the Enter key. If keys need to be chorded, they appear together in the same bracket with a plus sign between them: [Ctrl+Alt]. |
| 1. | Numbered lists represent procedures with sequential steps. |
| ◆ | Bullet lists provide information, but do not involve sequential steps. |
| > | Indicates selecting consecutive options (such as on a menu or dialog box). For example, Start > Run means to open the <i>Start</i> menu, and then select <i>Run</i> . |
|  | Indicates critical information. |

Chapter 1

Introduction

Overview

ATEN PE5108-ATB / PE5208-ATB / PE6108-ATB / PE6208-ATB / PE8108-ATB / PE8208-ATB eco PDUs are intelligent PDUs that contain 8 AC outlets for convenient and efficient data power usage management, and are available in various IEC or NEMA socket configurations.

They provide secure, centralized, intelligent power management (power on, off, cycle) for data center IT equipment (servers, storage systems, KVM switches, network devices, serial data devices, etc.), as well as the ability to monitor the center's environment conditions via sensors*. The basic characteristics of each model are shown in the table on page 3.

ATEN eco PDUs offer remote power control combined with real-time power measurement, allowing users to control and monitor the power status of all devices powered by the PDUs, either at the PDU device or outlet level, from practically any location via a TCP/IP connection.

The power status of each outlet can be set individually, allowing users to switch each device on/off. The eco PDU also offers comprehensive power analysis reports that can be separated by departments and/or locations, providing precise measurements of the current, voltage, power, and watt-hour in real time.

Installation and operation is fast and easy: as simple as plugging cables into their appropriate ports and configuring on a user-friendly web browser for intuitive management. Since the eco PDU firmware is upgradeable over a network, users can keep the PDUs updated with the latest functionality improvements by downloading updates from their product pages, as they become available.

ATEN eco PDU supports any 3rd-party SNMP v3 manager software and ATEN eco DC (eco PDU manager web GUI). ATEN eco DC provides you with an easy method for managing multiple devices, offering an intuitive and user-friendly graphical user interface that allows you to configure a PDU device and monitor power status of the equipment connected.

This series of ATEN eco PDUs have a circuit breaker alert that can sound an alarm and send SNMP trap or e-mail alerts when a trip occurs. This feature

provides a faster response time to recover servers and other devices during power loss due to circuit overload.

With its advanced security features and ease of operation, the eco PDU is the most convenient, reliable, and cost-effective way to remotely manage power access for multiple computer installations and allocate power resources efficiently.

Note: Sensors are optional accessories. A sensor-enabled installation is required to generate a more complete energy-efficient data and chart. Higher sensor installation density is helpful to generate more accurate data. See *Optional Accessories*, page 7, for further information.

PE Series eco PDU Comparison Chart

Model	Power Cord (IEC C19 to)	Outlets	Monitoring Level	Amps	
				Per Port	Total
PE5108A	NEMA 5-15P	NEMA 5-15R	PDU	12A	12A
PE5108B	NEMA 6-15P	IEC C13	PDU	12A	12A
PE5108G	IEC C14	IEC C13	PDU	10A	10A
PE5208A	NEMA 5-20P	NEMA 5-20R	PDU	16A	16A
PE5208B	NEMA 6-20P	IEC C13 / C19	PDU	12A / 16A	12A
PE5208G	IEC C20	IEC C13 / C19	PDU	10A / 16A	16A
PE6108A	NEMA 5-15P	NEMA 5-15R	PDU	12A	12A
PE6108B	NEMA 6-15P	IEC C13	PDU	12A	12A
PE6108G	IEC 60320 C14	IEC C13	PDU	10A	10A
PE6208A	NEMA 5-20P	NEMA 5-20R	PDU	16A	16A
PE6208B	NEMA 6-20P	IEC C13 / C19	PDU	12A / 16A	16A
PE6208G	IEC C20	IEC C13 / C19	PDU	10A / 16A	16A
PE8108A	NEMA 5-15P	NEMA 5-15R	Outlet	12A	12A
PE8108B	NEMA 6-15P	IEC C13	Outlet	12A	12A
PE8108G	IEC C14	IEC C13	Outlet	10A	10A
PE8208A	NEMA 5-20P	NEMA 5-20R	Outlet	16A	16A
PE8208B	NEMA 6-20P	IEC C13 / C19	Outlet	12A / 16A	16A
PE8208G	IEC C20	IEC C13 / C19	Outlet	10A / 16A	16A

Note: For the complete specifications of individual models, please refer to *Specifications*, page 95.

Features

Power Distribution

- ◆ Space saving 1U rack mount design with rear mounting
- ◆ IEC or NEMA outlet models
- ◆ 3 digit 7-segment front panel LED display showing the current, IP address of PDU, and outlets
- ◆ Remote users can monitor outlet status via web browsers
- ◆ Safe shutdown support
- ◆ Separate power for the unit's own power and power outlets. The user interface is kept accessible even when an overload trips the devices' circuit breaker

Remote Access

- ◆ Remote power control via TCP/IP and a built-in 10/100 Ethernet port
- ◆ Network interfaces: TCP/IP, UDP, HTTP, HTTPS, SSL, SMTP, DHCP, NTP, DNS, 10 Base-T / 100 Base-TX, auto sense, Ping
- ◆ eco PDU Power Management web GUI—eco DC
- ◆ SNMP v3 Manager support
- ◆ Telnet support

Operation

- ◆ Remote power outlet control (On, Off, Power Cycle) by individual outlets
- ◆ Power-on sequencing—users can set the power on sequence and delay time for each port to allow equipment to be turned on in the proper order
- ◆ Easy setup and operation via a browser-based user interface
- ◆ Multiple browsers support (IE, Firefox, Chrome, Safari, Opera, Netscape)
- ◆ RTC support to keep the timer running during times of no power.
- ◆ Up to 8 user accounts and 1 administrator account.
- ◆ Proactive Overload Protection (POP)—automatically powers off outlets in the user-defined sequence when a current overload occurs in protecting the powered devices

Management

- ◆ Power status measurement at the PDU/outlet level
- ◆ LED indicators for current and IP address at the PDU device and / or outlet levels.
- ◆ Real-time current, voltage, and kWh displayed in a browsed-based UI for monitoring at the PDU level (PE5108 / PE5208 / PE6108 / PE6208) and at the outlet level (PE7108 / PE7208 / PE8108 / PE8208)
- ◆ Circuit breaker alert sounds an alarm and sends SNMP trap or e-mail alerts when a circuit breaker trips
- ◆ Current and voltage threshold setting
- ◆ Outlet naming support
- ◆ User outlet access assignment on an outlet-by-outlet basis.
- ◆ Event logging and Syslog server support
- ◆ Upgradable firmware
- ◆ Multiple languages support: English, Traditional Chinese, Simplified Chinese, Japanese, German, Italian, Spanish, and French.

Security

- ◆ Two-level password security
- ◆ Strong security features include password strength protection and advanced encryption technologies—TLS 1.2
- ◆ Remote authentication support—RADIUS

Features available only on firmware-upgraded models with -ATB part number

- ◆ Supports SMPTS, IPv6, Modbus (Over TCP/IP), Auto Ping, TLS1.2, SSH
- ◆ Supports IEEE 802.1X
- ◆ Authentication: LDAP, TACACS+
- ◆ UI – heartbeat,schedule control, mail control, and setting rule

Requirements

- ◆ Browsers accessing the eco PDU unit must support TLS 1.2.
- ◆ For cold booting of attached computers, the computer's BIOS must support *Wake on LAN* or *System after AC Back*.
- ◆ For safe shutdown:
 - ◆ The computer must be running Windows (Windows 2000 or above) or Linux.
 - ◆ The *Safe Shutdown* program—PMonitor—must be installed and running on the computer (available by download from our website).

Note:

Safe shutdown program PMonitor can be downloaded from the *Support and Download* section of the product web page, as shown below:

Software & Drivers ▾

OS	Description	Ver.	Release Date	File Name
Other				
	MIB File	v1.1.115	2015-05-05	PE_MIB_File_v1.1.115.zip
	PE MIB File	v1.1.112	2014-06-19	PE8_MIB_File_v1.1.112.tar
	PE MIB File	v1.1.109	2013-09-06	PE8_MIB_File_v1.1.109.tar
	IP Installer	v1.4.132	2012-02-10	IPInstaller-ALTUSEN_v1.4.132.zip
Linux	PMonitor	v1.1	2012-02-10	PowerMonitor_v1.1.zip
Windows	PMonitor	v1.0.081	2012-02-10	PMonitorSrv_v1.0.081.zip
	PE MIB File	v1.0.063	2012-02-10	PE8_MIB_File_v1.0.063.zip

Optional Accessories

Sensors

Sensors are optional accessories. You can use the eco PDU unit without sensors. However, if you want to have complete energy management of an instrumented data center with the use of the eco PDU, you would need to use eco DC, a management web GUI, and install 4 sensors for each of the racks to generate a complete energy-efficient data and chart. 8-port models have 2 sensor ports. In this case, sensor 1 needs to be installed at the intake of the rack and sensor 2 needs to be placed at the exhaust of IT equipment of the rack. A sensor-enabled installation is required to generate a more complete energy-efficient data and chart. Higher sensor installation density is helpful to generate more accurate data. Available sensors are shown in the table, below:

Sensor	Part Number
Temperature	EA1140
Temperature / Humidity	EA1240
Differential Pressure / Temperature	EA1340

Sensor Management

Sensors can be managed via the eco PDU's built-in graphical user interface (GUI) or with ATEN eco DC that can be downloaded from the ATEN website.

Cable Holders

Cable holders are optional accessories. For added safety, use ATEN Lok-U-Plug cable holders to secure the connecting cables of your attached devices in place on the eco PDU. Use only the ATEN Lok-U-Plug cable holders that have been specifically designed to work with eco PDU. Using any other types of cable securing device could be highly dangerous.

Part Number	Description
2X-EA07	Lok-U-Plug Cable Holder (10 pcs)
2X-EA08	Lok-U-Plug Installation Tool (4 pcs)

Components

PE5108A Front View

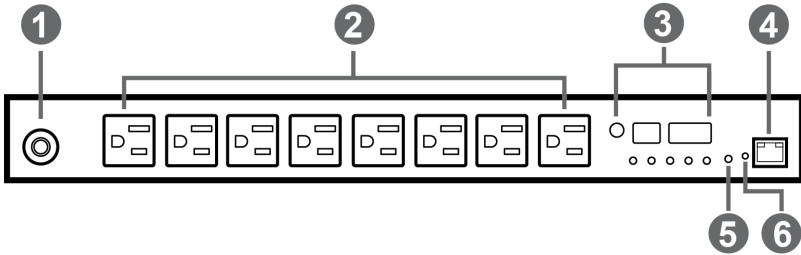

PE5208A Front View

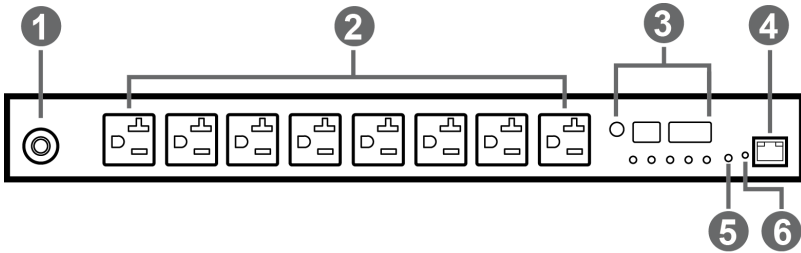

PE5108A / PE5208A Rear View

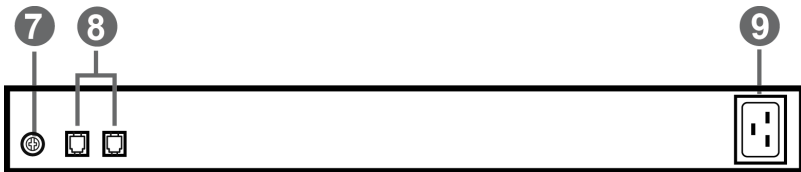

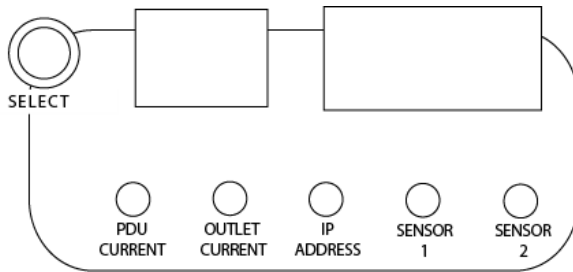
PE5108A / PE5208A Readout Section

No.	Item	Description
1	circuit breaker pushbutton	As a safety measure, if there is a current overload in regards to the device's power, the circuit breakers will trip. Press the button to recover normal operation.
2	power sockets	8 x NEMA 5-15R or 8 x NEMA 5-20R Note: Holes for ATEN Lok-U-Plug cable holders are located around the sockets. See <i>Securing the Cables</i> , page 23, for further information.
3	readout section	<ul style="list-style-type: none"> ◆ The selection (PDU Current / Outlet Current / IP Address) appears in the first (1-digit) display window. ◆ PDU Current / Outlet Current / IP Address appear in the second (3-digit) display window ◆ The LEDs above the items indicate which one the readout relates to. ◆ Press the button next to the first display window to cycle the selection among the items.
4	LAN port and LEDs	The cable that connects the eco PDU to the LAN plugs in here. The Link and LAN LEDs are built into the LAN port: Link: Lights GREEN to indicate that a connection via the eco PDU's RJ-45 Ethernet port has been established. Flashes to indicate data is being transmitted. LAN: Lights ORANGE to indicate 10 Mbps data transmission speed. The LED lights GREEN to indicate 100 Mbps data transmission speed.
5	reset button	This button is recessed and must be pushed with a thin object, such as the end of a paper clip. <ul style="list-style-type: none"> ◆ Press and release to reboot the device. ◆ Press and hold for more that three seconds to reset the eco PDU to its factory default settings

No.	Item	Description
6	power LED	The LED lights when the eco PDU is ready to operate.
7	grounding terminal	The wire used to ground the unit connects here.
8	sensor ports	External sensors plug into these two RJ-11 ports.
9	power socket	The power cord that connects the unit to an AC power source plugs in here.

PE5108B / PE5108G Front View

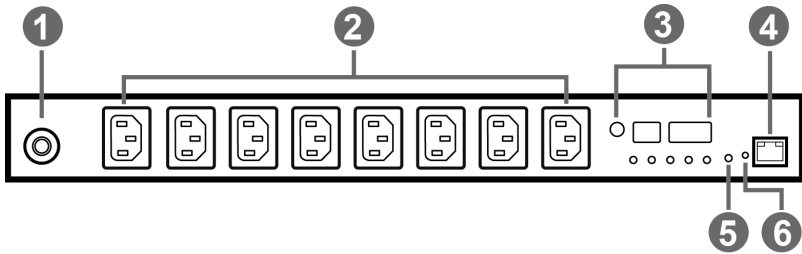

PE5208B / PE5208G Front View

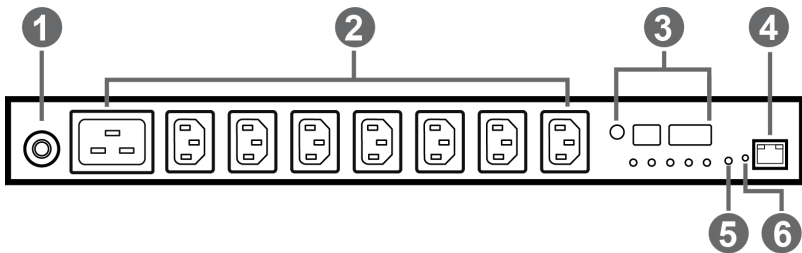

PE5108B / PE5108G / PE5208B / PE5208G Rear View

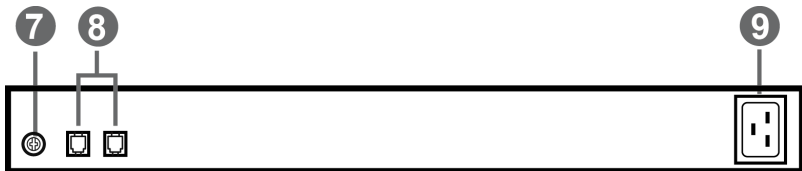

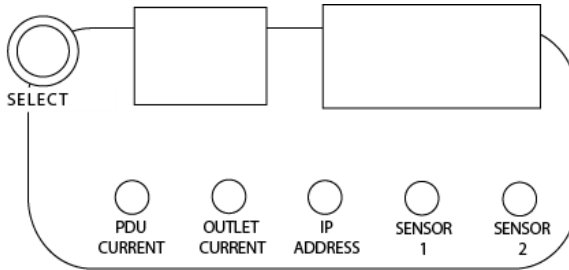
PE5108B / PE5108G / PE5208B / PE5208G Readout Section

No.	Item	Description
1	circuit breaker pushbutton	As a safety measure, if there is a current overload in regards to the device's power, the circuit breakers will trip. Press the button to recover normal operation.
2	power sockets	8 x IEC60320 C13 or 7 x IEC60320 C13 + 1 x C19 Note: Holes for ATEN Lok-U-Plug cable holders are located around the sockets. See <i>Securing the Cables</i> , page 23, for further information.
3	readout section	<ul style="list-style-type: none"> ◆ The selection (PDU Current / Outlet Current / IP Address) appears in the first (1-digit) display window. ◆ PDU Current / Outlet Current / IP Address appear in the second (3-digit) display window ◆ The LEDs above the items indicate which one the readout relates to. ◆ Press the button next to the first display window to cycle the selection among the items.
4	LAN port and LEDs	The cable that connects the eco PDU to the LAN plugs in here. The Link and LAN LEDs are built into the LAN port: Link: Lights GREEN to indicate that a connection via the eco PDU's RJ-45 Ethernet port has been established. Flashes to indicate data is being transmitted. LAN: Lights ORANGE to indicate 10 Mbps data transmission speed. The LED lights GREEN to indicate 100 Mbps data transmission speed.
5	reset button	This button is recessed and must be pushed with a thin object, such as the end of a paper clip. <ul style="list-style-type: none"> ◆ Press and release to reboot the device. ◆ Press and hold for more that three seconds to reset the eco PDU to its factory default settings

No.	Item	Description
6	power LED	The LED lights when the eco PDU is ready to operate.
7	grounding terminal	The wire used to ground the unit connects here.
8	sensor ports	External sensors plug into these two RJ-11 ports.
9	power socket	The power cord that connects the unit to an AC power source plugs in here.

PE6108A / PE8108A Front View

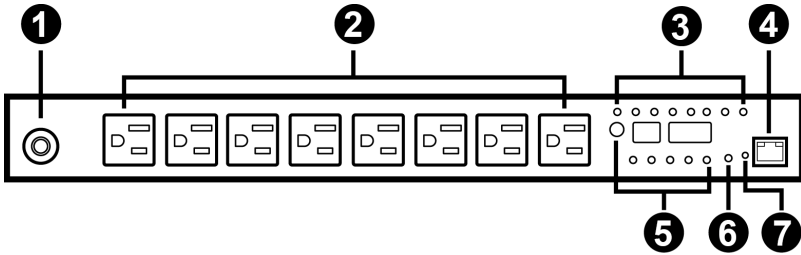

PE6208A / PE8208A Front View

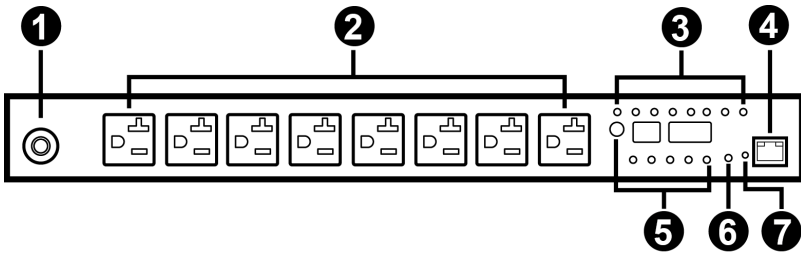

PE6108A / PE6208A / PE8108A / PE8208A Rear View

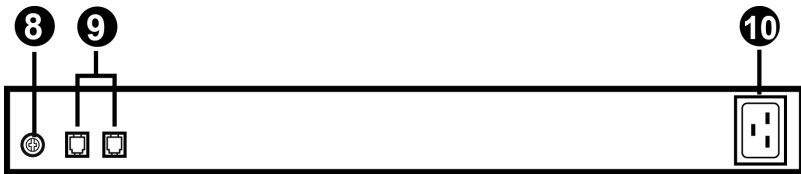

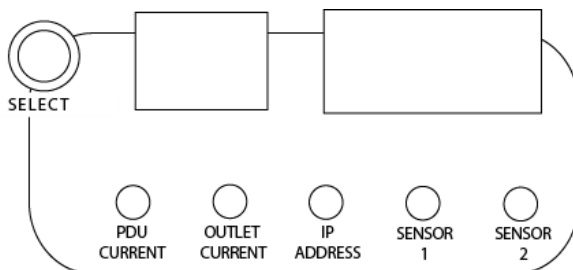
PE6108A / PE6208A / PE8108A / PE8208A Readout Section

No.	Item	Description
1	circuit breaker pushbutton	As a safety measure, if there is a current overload in regards to the device's power, the circuit breakers will trip. Press the button to recover normal operation.
2	power sockets	8 x NEMA 5-15R or 8 x NEMA 5-20R Note: Holes for ATEN Lok-U-Plug cable holders are located around the sockets. See <i>Securing the Cables</i> , page 23, for further information.
3	outlet status LEDs	These LEDs indicate outlet status. Lights orange for powered on. Off for powered off.
4	LAN port and LEDs	The cable that connects the eco PDU to the LAN plugs in here. The Link and LAN LEDs are built into the LAN port: Link: Lights GREEN to indicate that a connection via the eco PDU's RJ-45 Ethernet port has been established. Flashes to indicate data is being transmitted. LAN: Lights ORANGE to indicate 10 Mbps data transmission speed. The LED lights GREEN to indicate 100 Mbps data transmission speed.
5	readout section	<ul style="list-style-type: none"> ◆ The selection (PDU Current / Outlet Current / IP Address) appears in the first (1-digit) display window. ◆ PDU Current / Outlet Current / IP Address appear in the second (3-digit) display window ◆ The LEDs above the items indicate which one the readout relates to. ◆ Press the button next to the first display window to cycle the selection among the items.

No.	Item	Description
6	reset button	<p>This button is recessed and must be pushed with a thin object, such as the end of a paper clip.</p> <ul style="list-style-type: none">◆ Press and release to reboot the device.◆ Press and hold for more than three seconds to reset the eco PDU to its factory default settings
7	power LED	The LED lights when the eco PDU is ready to operate.
8	grounding terminal	The wire used to ground the unit connects here.
9	sensor ports	External sensors plug into these two RJ-11 ports.
10	power socket	The power cord that connects the unit to an AC power source plugs in here.

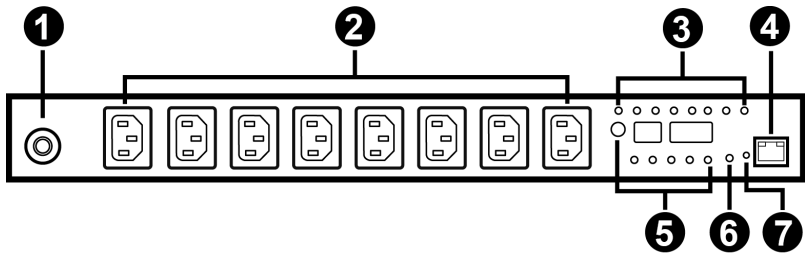
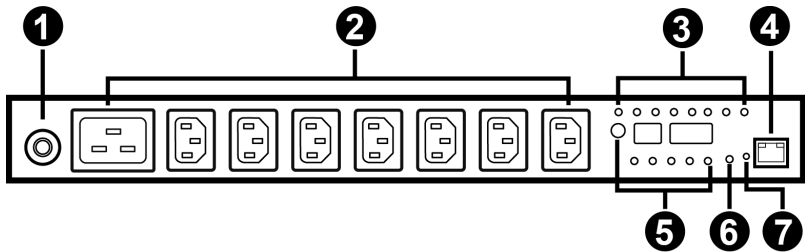
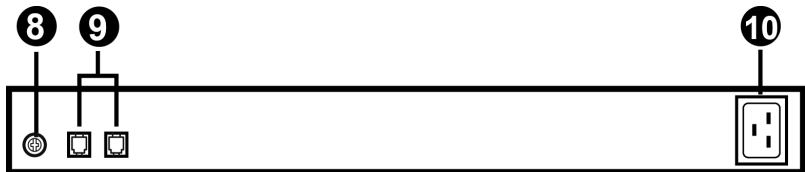
PE6108B / PE6108G / PE8108B / PE8108G Front View**PE6208B / PE6208G / PE8208B / PE8208G Front View****PE6108B / PE6108G / PE6208B / PE6208G / PE8108B / PE8108G / PE8208B / PE8208G Rear View**

PE6108B / PE6108G / PE6208B / PE6208G / PE8108B / PE8108G / PE8208B / PE8208G Readout Section

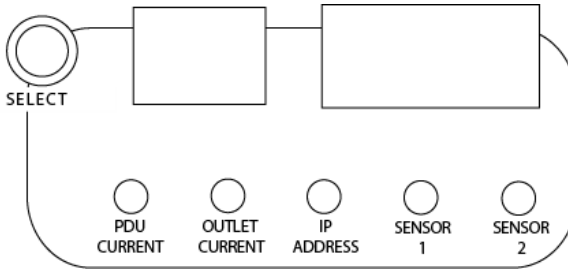

No.	Item	Description
1	circuit breaker pushbutton	As a safety measure, if there is a current overload in regards the device's power, the circuit breakers will trip. Press the button to recover normal operation.
2	power sockets	8 x IEC320 C13 or 7 x IEC320 C13 + 1 x C19 Note: Holes for ATEN Lok-U-Plug cable holders are located around the sockets. See <i>Securing the Cables</i> , page 23, for further information.
3	outlet status LEDs	These LEDs indicate outlet status. Lights orange for powered on. Off for powered off.
4	LAN port and LEDs	The cable that connects the eco PDU to the LAN plugs in here. The Link and LAN LEDs are built into the LAN port: Link: Lights GREEN to indicate that a connection via the eco PDU's RJ-45 Ethernet port has been established. Flashes to indicate data is being transmitted. LAN: Lights ORANGE to indicate 10 Mbps data transmission speed. The LED lights GREEN to indicate 100 Mbps data transmission speed.
5	readout section	<ul style="list-style-type: none"> ◆ The selection (PDU Current / Outlet Current / IP Address) appears in the first (1-digit) display window. ◆ PDU Current / Outlet Current / IP Address appear in the second (3-digit) display window ◆ The LEDs above the items indicate which one the readout relates to. ◆ Press the button next to the first display window to cycle the selection among the items.

No.	Item	Description
6	reset button	This button is recessed and must be pushed with a thin object, such as the end of a paper clip. <ul style="list-style-type: none">◆ Press and release to reboot the device.◆ Press and hold for more than three seconds to reset the eco PDU to its factory default settings
7	power LED	Lights when the unit is powered up and ready to operate.
8	grounding terminal	The wire used to ground the unit connects here.
9	sensor ports	External sensors plug into these two RJ-11 ports.
10	power socket	The power cord that connects the unit to an AC power source plugs in here.

This Page Intentionally Left Blank

Chapter 2

Hardware Setup

Before You Begin



1. Important safety information regarding the placement of this device is provided on page 83. Please review it before proceeding.
2. Make sure that power to all the devices you will be connecting have been turned off. You must unplug the power cords of any computers that have the Keyboard Power On function.



1. Vous trouverez des informations de sécurité importantes concernant le positionnement de l'unité à la page 83. Veuillez les lire attentivement avant d'aller plus loin.
2. Vérifiez que tous les périphériques à connecter sont éteints. Vous devez débrancher les câbles d'alimentation des ordinateurs disposant de la fonction de mise sous tension à partir du clavier.

Rack Mounting

The eco PDU can be mounted in a 19" (1U) rack. To rack mount the device, use the rack mounting brackets that came with your device. The brackets can be screwed to the front or rear sides of the device, and then the unit can slide into the front of the rack, as shown in the diagram below:

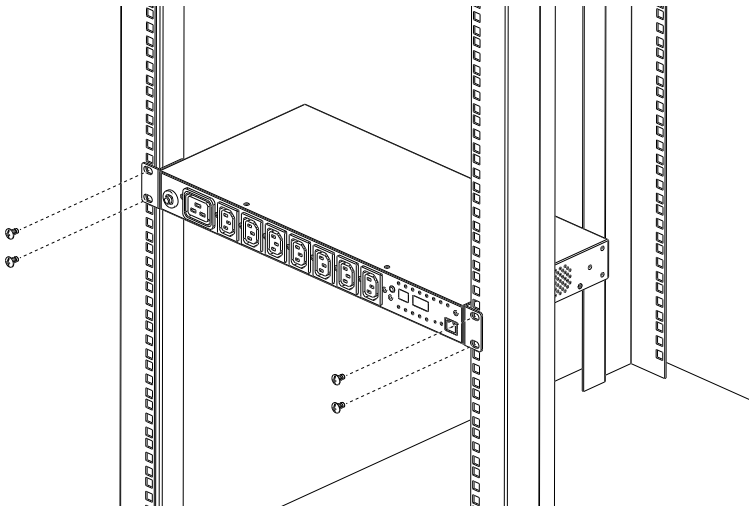

Installation

To set up your eco PDU installation, refer to the installation diagram on the next page (the numbers in the diagram correspond to the numbered steps), and do the following:

1. Use a grounding wire to ground the eco PDU by connecting one end of the wire to its grounding terminal, and the other end of the wire to a suitable grounded object.

Note: Do not omit this step. Proper grounding helps to prevent damage to the unit from surges or static electricity.

2. For each device you want to connect, use its power cable to connect from the device's AC socket to any available outlet on the eco PDU.
3. Plug the cable that connects the eco PDU to the LAN into the eco PDU's LAN port.
4. If you are using sensors in your eco PDU installation, connect them to the sensor ports on the unit's rear side panel.

Note: Sensors are optional. Please see *Optional Accessories*, page 7, and the detailed sensor installation diagrams later in this chapter for further information.

5. Connect the eco PDU's power cord to an AC power source.

Note: We strongly advise that you do not plug the eco PDU into a multi socket extension cord, since it may not receive enough amperage to operate correctly.

Once you have finished these installation steps, you can turn on the eco PDU and the connected devices.

Note: We strongly recommend using cable ties and cable bars to safely and securely route the cables attached to the front of the unit.

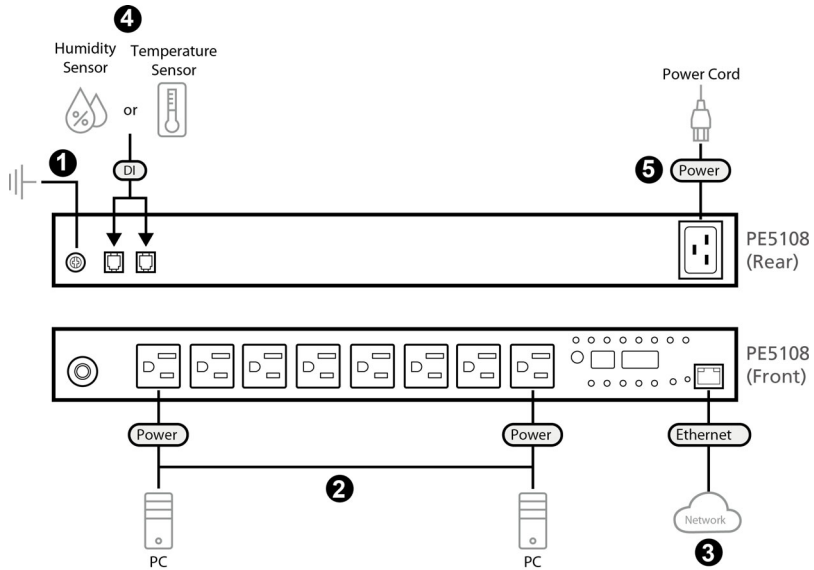

Securing the Cables

For added safety, use ATEN Lok-U-Plug cable holders to secure the cables from your attached devices in place on the eco PDU unit. Secure the cable holders using the specially designed holes around the individual power outlets, as shown below:

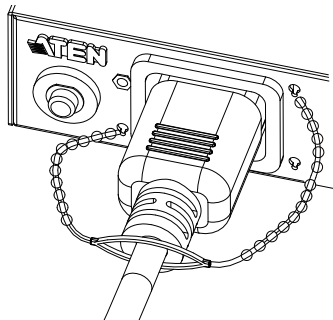

Note: 1. Cable holders are an optional accessory. See *Cable Holders*, page 7.

2. Use only the ATEN Lok-U-Plug cable holders that have been specifically designed to work with the eco PDU. Using any other kind of cable securing device could be highly dangerous.

Securing the Sensors

Connect the sensors to the eco PDU's front panel sensor ports and secure them using sensor mounts, tie wraps, and adhesive cable tie holders. If you use a tie wrap to secure the sensor, tighten the tie wrap over the recessed channel on the sensor, as shown in the following diagram:

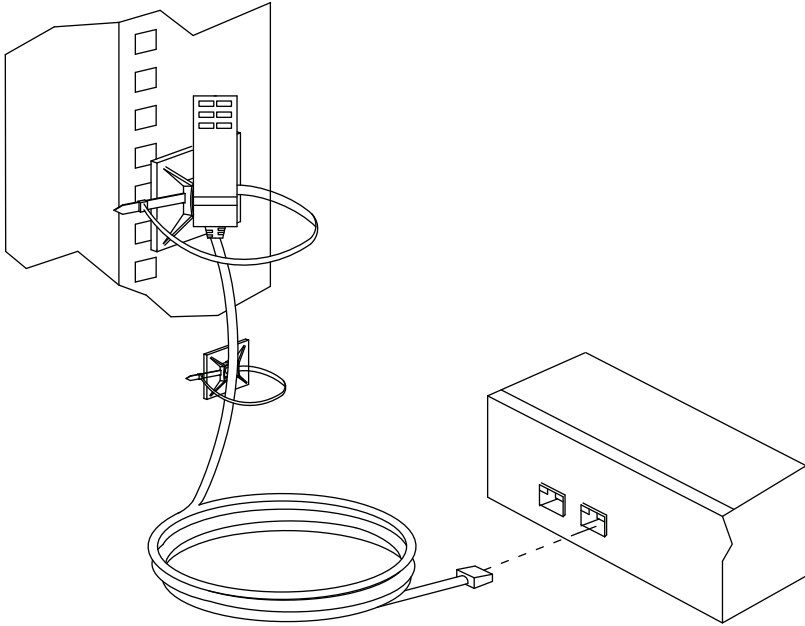

-
- Note:**
1. The sensors shown in the above diagram are for reference purposes only. The sensors for the eco PDU may look slightly different.
 2. Depending on the model and type of sensor, sensor mounts, tie wraps, and adhesive cable tie holders may or may not be provided in the package.
-

Chapter 3

Basic Operation and First-Time Setup

Operation Methods

eco PDU models provide three methods to access and manage your installation: Browser, eco DC (eco PDU management web GUI), and SNMP.

Note: The following sections of this chapter contain information concerning Browser operation. For eco DC operation, please reference the separate eco DC user manual. The eco DC web GUI and user manual can be downloaded from the ATEN website.

Browser

The eco PDU can be accessed and controlled via any supported Internet browser from any platform. See *First-Time Setup*, page 26, and the following sections in this chapter, for full details.

eco DC

The eco DC Energy Management Software. eco DC provides you with an easy method for managing multiple devices, offering an intuitive and user-friendly Graphical Interface that allows you to configure a PDU device and monitor power status of the equipment connected to it. eco DC Energy Management Software can be downloaded from the ATEN website, along with a separate eco DC User Manual.

SNMP

The eco PDU supports any 3rd party V3 SNMP Manager Software. SNMP Management Information Database (MIB) files for the eco PDU device can be found on the software.

First-Time Setup

Once the eco PDU installation has been cabled up, the next task the Administrator needs to perform involve configuring the network parameters, changing the default Super Administrator login settings, and adding users.

The way to accomplish this is to log in via web browser.

- Note:**
1. Since this is the first time you are logging in, use the default Username: *administrator*; and the default Password: *password*. For security purposes we recommend changing them to something unique (see *Changing the Administrator Login*, page 28).
 2. For remote methods of getting logged in to the PDU, see *IP Address Determination*, page 93.

After you successfully log in, the eco PDU Energy/Connections page appears:

Connections | Configuration | Heartbeat | Autoping

Station List

PE8208 | PE8208 | derek

[01]
[02]
[03]
[04]
[05]
[06]
[07]
[08]

PDU Status

PDU Name	Measurement	Min Threshold	Max Threshold	PDU Status
PE8208 __derek	Aggregate current	0.00 A	1.0	<input checked="" type="checkbox"/> ON <input type="checkbox"/> OFF <input type="checkbox"/> Reboot
	Voltage	111.26 V		
	Power	0.0000 W		
	Aggregate power dissipation	0.0000 KWH		

Sensor Status

Sensor Port	Address	Temperature	Humidity	Pressure
Sensor1	1	N/A	N/A	N/A
Sensor2	1	N/A	N/A	N/A

Outlet Status

Outlet	Outlet Name	Measurement	Min Threshold	Max Threshold	Outlet Status	Outlet Switching
[01]		Current	0.00 A	0.0	<input checked="" type="checkbox"/> ON <input type="checkbox"/> OFF <input type="checkbox"/> Reboot	
		Voltage	111.26 V			
		Power	0.0000 W	1.0		
		Power Dissipation	0.0000 KWH			
		Power factor	1.00			
		Current	0.00 A	0.0	<input checked="" type="checkbox"/> ON	
		Voltage	111.26 V			

ATEN International Co., Ltd. All rights reserved.

Note: Operation details are discussed in *Energy*, page 32, in the next chapter. For further setup information, continue with this chapter

Network Configuration

To configure the network settings, do the following:

1. Click the **Setup** tab.
2. The interface displays the **Device Configuration** page. A screen similar to the one below appears:

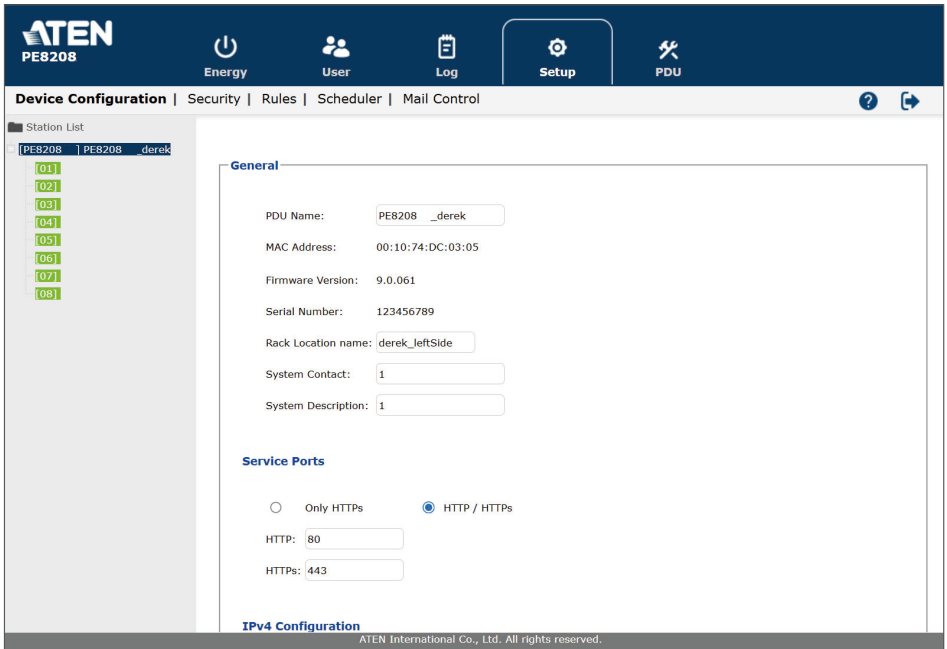

Station List

- PEB208
- PEB208 _derek
- [01]
- [02]
- [03]
- [04]
- [05]
- [06]
- [07]
- [08]
- [09]

General

PDU Name: PEB208 _derek

MAC Address: 00:10:74:DC:03:05

Firmware Version: 9.0.061

Serial Number: 123456789

Rack Location name: derek_leftSide

System Contact: 1

System Description: 1

Service Ports

Only HTTPs HTTP / HTTPs

HTTP: 80

HTTPS: 443

IPv4 Configuration

ATEN International Co., Ltd. All rights reserved.

3. Fill in the fields according to the information provided under *Device Configuration*, page 54.

Changing the Administrator Login

To change the default Administrator username and password, do the following:

1. Click the **User** tab. The *Accounts* page has a detailed list of users—with more information about them—in the large central panel:

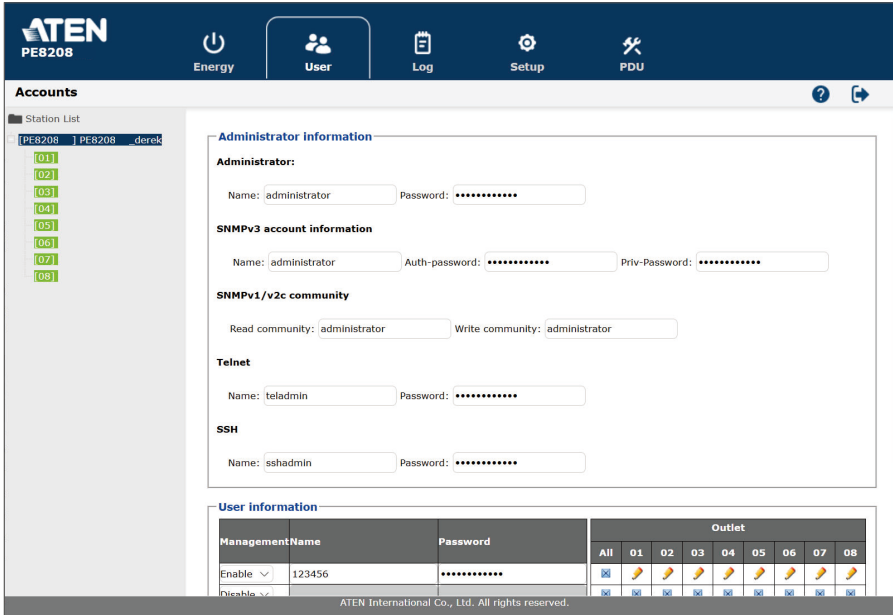

2. In the **Administrator Information** section, reset the name and password fields to something unique, then click **Save** (at the bottom of the page.)

Note: If you forget the Administrator’s name or password, short the mainboard jumper to restore the default Administrator account. See *Administrator Login Failure*, page 107 in the Appendix for full details.

Moving On

After setting up the network and changing the default Administrator username and password, you can proceed to other administration activities—including adding users. This is covered in the next chapter.

Chapter 4

Browser Operation

Logging In

The eco PDU can be accessed via a supported Internet browser from any platform.

Note: Browsers must support TLS 1.0.

To access the eco PDU do the following:

1. Open your browser and specify the IP address of the eco PDU you want to access in the browser's URL location bar.

Note: You can get the IP address from the eco PDU administrator, or see *IP Address Determination*, page 93, for information about setting it up yourself.

2. If a security alert dialog box appears, accept the certificate—it can be trusted. The login page appears:

The screenshot shows the login interface for the ATEN NRGence™ PE8208. The header includes the ATEN logo and the product name. The main content area is a white box with a dark blue background. It contains the following elements:

- Please Log In** (Section Header)
- Username** (Text input field)
- Password** (Text input field with a lock icon)
- Language** (Dropdown menu set to English)
- Login** (Green button)
- [Reset login page](#) (Text link)

At the bottom of the page, there is a small copyright notice: ATEN International Co., Ltd. All rights reserved.

3. Provide a valid username and password (set by the administrator).
4. Select your preferred language from the drop-down menu.
5. Then click **Login** to bring up the browser main page.

The eco PDU Main Page

After you have successfully logged in, the eco PDU Main Page comes up with the Energy *Connections* page displayed:

Station List

PE8208 PE8208 derek

[01]
[02]
[03]
[04]
[05]
[06]
[07]
[08]

PDU Status

PDU Name	Measurement	Min Threshold	Max Threshold	PDU Status
PE8208 _derek	Aggregate current	0.00 A		ON OFF <input type="checkbox"/> Reboot
	Voltage	111.08 V		
	Power	0.0000 W		
	Aggregate power dissipation	0.0000 KWH		

Sensor Status

Sensor Port	Address	Temperature	Humidity	Pressure
Sensor1	1	N/A	N/A	N/A
Sensor2	1	N/A	N/A	N/A

Outlet Status

Outlet Name	Measurement	Min Threshold	Max Threshold	Outlet Status	Outlet Switching
[01]	Current	0.00 A	0.0	ON	ON OFF <input type="checkbox"/> Reboot
	Voltage	111.08 V			
	Power	0.0000 W	1.0		
	Power Dissipation	0.0000 KWH			
	Power factor	1.00			
[02]	Current	0.00 A	0.0	ON	ON OFF <input type="checkbox"/> Reboot
	Voltage	111.08 V			
	Power	0.0000 W	1.0		
	Power Dissipation	0.0000 KWH			
	Power factor	1.00			

ATEN International Co., Ltd. All rights reserved.

Note: The screen depicts an Administrator’s page. Depending on a user’s type and permissions, not all of these elements appear.

Page Components

The web page screen components are described in the table, below:

No.	Item	Description
1	Tab Bar	The tab bar contains the eco PDU's main operation categories. The items that appear in the tab bar are determined by the user's type, and the authorization options that were selected when the user's account was created.
2	Menu Bar	The menu bar contains operational sub-categories that pertain to the item selected in the tab bar. The items that appear in the menu bar are determined by the user's type, and the authorization options that were selected when the user's account was created.
3	Sidebar	The Sidebar provides a tree view listing of outlets that relate to the various tab bar and menu bar selections.
4	Help	Connects to on-line help at the ATEN website for the device's configuration and operation.
5	Logout	Click this button to log out of your eco PDU session.
6	Interactive Display Panel	This is your main work area. The screens that appear reflect your menu choices and Sidebar node selection.

Energy

Connections

When you log in to the eco PDU, the interface opens with its default selection of the *Energy* tab; and the *Connections* menu. The contents of the **PDU Status**, **Sensor Status**, and **Outlet Status** sections are displayed in the main panel.

The screenshot shows the ATEN PE8208 PDU web interface. The top navigation bar includes the ATEN logo, a power icon labeled 'Energy', a user icon labeled 'User', a log icon labeled 'Log', a settings icon labeled 'Setup', and a wrench icon labeled 'PDU'. Below the navigation bar, the 'Connections' menu is active, showing sub-menus for 'Configuration', 'Heartbeat', and 'Autoping'. The main content area is divided into three sections:

PDU Status

PDU Name	Measurement	Value	Min Threshold	Max Threshold	PDU Status
PE8208 _derek	Aggregate current	0.00 A			<input checked="" type="radio"/> ON <input type="radio"/> OFF <input type="checkbox"/> Reboot
	Voltage	111.00 V			
	Power	0.0000 W			
	Aggregate power dissipation	0.0000 KWH			

Sensor Status

Sensor Port	Address	Temperature	Humidity	Pressure
Sensor1	1	N/A	N/A	N/A
Sensor2	1	N/A	N/A	N/A

Outlet Status

Outlet	Outlet Name	Measurement	Value	Min Threshold	Max Threshold	Outlet Status	Outlet Switching
[01]		Current	0.00 A	0.0	10.0	ON	<input checked="" type="radio"/> ON <input type="radio"/> OFF <input type="checkbox"/> Reboot
		Voltage	111.00 V				
		Power	0.0000 W		1.0		
		Power Dissipation	0.0000 KWH				
		Power factor	1.00				
[02]		Current	0.00 A	0.0	10.0	ON	<input checked="" type="radio"/> ON <input type="radio"/> OFF <input type="checkbox"/> Reboot
		Voltage	111.00 V				
		Power	0.0000 W		1.0		
		Power Dissipation	0.0000 KWH				
		Power factor	1.00				
[03]		Current	0.00 A			ON	<input checked="" type="radio"/> ON <input type="radio"/> OFF <input type="checkbox"/> Reboot
		Voltage	111.00 V				
		Power	0.0000 W				

Copyright © 2018 ATEN International Co., Ltd. All rights reserved.

PDU Status

All eco PDU models support PDU device level monitoring. The **PDU Status** section allows you to set up a power management configuration for the PDU device as a whole:

PDU Status					
PDU Name	Measurement		Min Threshold	Max Threshold	PDU Status
PE8208 _derek	Aggregate current	0.00 A	<input type="text"/>	<input type="text"/>	<input type="button" value="ON"/> <input type="button" value="OFF"/> <input type="checkbox"/> Reboot
	Voltage	109.01 V	<input type="text"/>	<input type="text"/>	
	Power	0.0000 W	<input type="text"/>	<input type="text"/>	
	Aggregate power dissipation	0.0000 KWH	<input type="text"/>	<input type="text"/>	

- ◆ PDU Threshold Settings

These fields are used to set the maximum, minimum, and fluctuation threshold settings for Aggregate Current, Voltage, Power, and Aggregate Power Dissipation. If a range falls below the minimum setting, or exceeds the maximum setting an alarm is triggered. The *Aggregate Current* Max Threshold setting triggers the Proactive Overload Protection (POP) mode (see page 35).

- ◆ On / Off / Reboot

You can manually turn the device On and Off from this page by clicking the buttons. To Reboot the device, enable the Reboot checkbox and click on **Save** (located at the bottom of the page).

Sensor Status

If you have sensors installed in your installation, use these fields to set the maximum, minimum and fluctuation threshold settings for Temperature, Humidity, and Differential Pressure.

Sensor Status				
Sensor Port	Address	Temperature	Humidity	Pressure
Sensor1	1	N/A	N/A	N/A
Sensor2	1	N/A	N/A	N/A

Note: Sensors are optional accessories. Check with your dealer for details.

Outlet Status

The Outlet Status section allows you to set up a power management configuration for each of the individual outlets:

Outlet Status						
Outlet	Outlet Name	Measurement	Min Threshold	Max Threshold	Outlet Status	Outlet Switching
[01]	Olt01	Current	0.00 A	0.0	10.0	ON OFF <input type="checkbox"/> Reboot
		Voltage	109.69 V			
		Power	0.0000 W		1.0	
		Power Dissipation	0.0000 KWH			
		Power factor	1.00			
[02]	Olt02	Current	0.00 A	0.0	10.0	ON OFF <input type="checkbox"/> Reboot
		Voltage	109.69 V			
		Power	0.0000 W		1.0	
		Power Dissipation	0.0000 KWH			
		Power factor	1.00			
[03]	Olt03	Current	0.00 A			ON OFF <input type="checkbox"/> Reboot
		Voltage	109.69 V			
		Power	0.0000 W			
		Power Dissipation	0.0000 KWH			
		Power factor	1.00			
[04]		Current	0.00 A			ON OFF <input type="checkbox"/> Reboot
		Voltage	109.69 V			
		Power	0.0000 W			
		Power Dissipation	0.0000 KWH			
		Power factor	1.00			
[05]		Current	0.00 A			ON OFF <input type="checkbox"/> Reboot
		Voltage	109.69 V			
		Power	0.0000 W			
		Power Dissipation	0.0000 KWH			
		Power factor	1.00			

■ Threshold Settings

These fields are used to set the maximum and minimum threshold settings for the Aggregate Current, Voltage, Power, and Power Dissipation. If any of them falls below the minimum setting or exceeds the maximum setting, an alarm is triggered.

■ Outlet Status

Indicates each outlet status (ON / OFF / POP).

■ On / Off / Reboot

You can manually turn the outlet on or off from this page by clicking the ON / OFF buttons. To Reboot the device, enable the Reboot checkbox and click OFF (reboot only works on the eco PUDs with Outlet Status ON).

Configuration

The *Configuration* page is used to configure the settings of the PDU at the individual power outlet level.

The screenshot displays the ATEN PEB208 Configuration interface. The top navigation bar includes icons for Energy, User, Log, Setup, and PDU. The main content area is divided into several sections:

- POP Settings:** Includes checkboxes for 'Enable Outlet POP' (checked), 'Enable Bank POP LIFO Mode', and 'Enable Bank POP Priority Mode'.
- Power On Time Schedule Settings:** Includes a checkbox for 'Enable Power On Time Schedule'.
- Buzzer Setting:** Includes a checked checkbox for 'Enable Buzzer Alarm'.
- Outlet Reboot Setting:** Includes a checked checkbox for 'Enable Outlet Sequential Reboot'.
- Bank POP Priority List:** A table with 8 rows, each showing a priority level (Priority1 to Priority8) and an outlet (Outlet 1 to Outlet 8) with a dropdown arrow.
- Outlet Configuration:** A table with columns for Outlet Name, Confirmation Required, Outlet Locked, Delay Time (sec) (Power ON and Power OFF), Remote Turn ON Method, and Holiday Mode.

Outlet	Outlet Name	Confirmation Required	Outlet Locked	Delay Time (sec)		Remote Turn ON Method	Holiday Mode
				Power ON	Power OFF		
[01]	Out01	<input type="checkbox"/>	<input type="checkbox"/>	5	5	Method: Kill the Power MAC Address: 000000000000	Power OFF
[02]	Out02	<input type="checkbox"/>	<input type="checkbox"/>	1	1	Method: Kill the Power	Power OFF

ATEN International Co., Ltd. All rights reserved.

POP Settings

This section allows you to configure the settings for ATEN's exclusive Proactive Overload Protection (POP) technology. Effective on all non-critical outlets, this added safety feature automatically powers off when a current overload occurs. Check the checkbox and click Save to enable the selected POP mode(s).

Function	Description
Enable Outlet POP	Automatically powers off the outlets when a current overload occurs.
Enable Bank POP LIFO Mode	Automatically powers off the outlets in a last-in first-out sequence when a current overload occurs.
Enable Bank POP Priority Mode	Automatically powers off the outlets according to a pre-configured Bank POP Priority List.

■ POP Setting Scenarios

	Setting	Description
A	<div style="border: 1px solid black; padding: 5px;"> <p>POP Settings</p> <p><input checked="" type="checkbox"/> Enable Outlet POP</p> <p><input type="checkbox"/> Enable Bank POP LIFO Mode</p> <p><input type="checkbox"/> Enable Bank POP Priority Mode</p> </div>	<p>Triggers Proactive Overload Protection to power off an outlet when it's Current Max Threshold setting is exceeded. Only the outlet that exceeds the threshold setting is powered off.</p>
B	<div style="border: 1px solid black; padding: 5px;"> <p>POP Settings</p> <p><input checked="" type="checkbox"/> Enable Outlet POP</p> <p><input checked="" type="checkbox"/> Enable Bank POP LIFO Mode</p> <p><input type="checkbox"/> Enable Bank POP Priority Mode</p> </div>	<p>Triggers setting A and:</p> <p>Triggers Proactive Overload Protection to shut off power to a newly inserted device (LIFO), when it causes the PDU's Aggregate Current Max Threshold setting to be exceeded. Only the outlet with a newly inserted device is powered off; all other outlets stay on. If another outlet exceeds the Aggregate Current threshold, an alarm is triggered.</p>
C	<div style="border: 1px solid black; padding: 5px;"> <p>POP Settings</p> <p><input checked="" type="checkbox"/> Enable Outlet POP</p> <p><input checked="" type="checkbox"/> Enable Bank POP LIFO Mode</p> <p><input checked="" type="checkbox"/> Enable Bank POP Priority Mode</p> </div>	<p>Triggers setting A and:</p> <p>Triggers Proactive Overload Protection when the PDU's Aggregate Current Max Threshold setting is exceeded and shuts off power to the (LIFO) outlet first, and then the remaining outlets in order, according to the <i>Bank POP Priority List</i>. Any outlet set to N/A will not be powered off.</p>
D	<div style="border: 1px solid black; padding: 5px;"> <p>POP Settings</p> <p><input checked="" type="checkbox"/> Enable Outlet POP</p> <p><input type="checkbox"/> Enable Bank POP LIFO Mode</p> <p><input checked="" type="checkbox"/> Enable Bank POP Priority Mode</p> </div>	<p>Triggers setting A and:</p> <p>Triggers Proactive Overload Protection when the PDU's Aggregate Current Max Threshold setting is exceeded to power off outlets according to the <i>Bank POP Priority List</i>. Any outlet set to N/A will not be powered off.</p>

Power On Time Schedule Settings

Check the **Enable Power On Time Schedule** box to use the *Power ON Delay* setting to set the amount of time the eco PDU waits before powering on an outlet. See *Power ON Delay* in the table on the next page.

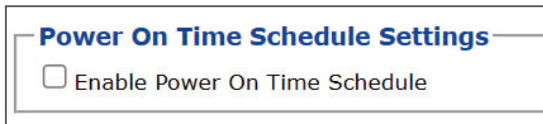

Buzzer Setting

Checking the **Enable Buzzer Alarm** box sounds an alarm and sends SNMP trap or e-mail alerts when a threshold setting exceeds the minimum or maximum setting.

Buzzer Setting

Enable Buzzer Alarm

Outlet Reboot Setting

Checking the **Enable Outlet Sequential Reboot** box allows you to sequentially reboot all outlets by pressing the Power Control Button of Outlet 1 for more than 8 seconds.

Outlet Reboot Setting

Enable Outlet Sequential Reboot

Bank POP Priority List

This field allows you to set up a POP priority list that the PDU powers off the outlets according to sequence configured in this list.

Bank POP Priority List		
Bank 1		
Priority1	Outlet 1	▼
Priority2	Outlet 2	▼
Priority3	Outlet 3	▼
Priority4	Outlet 4	▼
Priority5	Outlet 5	▼
Priority6	Outlet 6	▼
Priority7	Outlet 7	▼
Priority8	Outlet 8	▼

Outlet Configuration

Outlet Configuration lets you set up the power management configuration for the selected outlet. The meanings of the field headings are described in the following table.

Outlet Configuration							
Outlet	Outlet Name	Confirmation Required	Outlet Locked	Delay Time (sec)		Remote Turn ON Method	Holiday Mode
				Power ON	Power OFF		
[01]	Olt01	<input type="checkbox"/>	<input type="checkbox"/>	5	5	Method: Kill the Power MAC Address: 000000000000	Power OFF
[02]	Olt02	<input type="checkbox"/>	<input type="checkbox"/>	1	1	Method: Kill the Power MAC Address: 1C697AD1F750	Power OFF
[03]	Olt03	<input type="checkbox"/>	<input type="checkbox"/>	5	1	Method: Kill the Power MAC Address: 000000000000	Power OFF
[04]		<input type="checkbox"/>	<input type="checkbox"/>	5	1	Method: Kill the Power MAC Address: 000000000000	Power OFF
[05]		<input type="checkbox"/>	<input type="checkbox"/>	5	1	Method: Kill the Power MAC Address: 000000000000	Power OFF
[06]		<input type="checkbox"/>	<input type="checkbox"/>	5	1	Method: Kill the Power MAC Address: 000000000000	Power OFF
[07]		<input type="checkbox"/>	<input type="checkbox"/>	5	1	Method: Kill the Power MAC Address: 000000000000	Power OFF
[08]		<input type="checkbox"/>	<input type="checkbox"/>	5	1	Method: Kill the Power MAC Address: 000000000000	Power OFF

Heading	Meaning
Outlet	Shows the port number of the listed outlet.
Outlet Name	Each outlet can be given a distinctive name. The maximum number of characters is 15.
Confirmation Required	If this option is enabled (there is a check in the checkbox), a dialog box comes up asking you to confirm a power operation before it is performed. If it is disabled (there is no check in the checkbox), the operation is performed without confirmation.
Outlet Locked	Check this box to disable use of the front panel Power Control Button for the outlet. When you check the box the outlet's Local LED turns off and the Power Control Button will no longer reboot the outlet. Note: Uncheck the box to enable Local Mode.
Delay Time (sec) Power ON	Sets the amount of time the eco PDU waits after the Power Button is clicked (see <i>Outlet Status</i> , page 34), before it turns on the power to the outlet. You must check the <i>Enable Power On Time Schedule Setting</i> box for this setting to take effect. See <i>Power On Time Schedule Settings</i> , page 36, for details. Note: The default delay time is 0 seconds; the maximum is 999 seconds. When a series of outlets are scheduled to be powered up, they turn on in sequence with a default delay of 10 milliseconds between each outlet.

Heading	Meaning
Delay Time (sec) Power OFF	<p>Sets the amount of time the eco PDU waits after the Power Button is clicked (see <i>Outlet Status</i>, page 34), before it turns off the power to the outlet.</p> <p>For the <i>System after AC Back</i> option (see below), after the delay time expires, the eco PDU waits another fifteen seconds, then shuts the computer down.</p> <p>The default delay time is 15 seconds. The maximum delay time is 999 seconds.</p>
Remote Turn ON Method	<p>◆ Use the drop-down menu to select one of the choices, below:</p> <p>Wake on LAN: This is a Safe Shutdown and Restart option. If this is selected, when an Outlet is turned Off, the eco PDU first sends a message to the computer telling it to prepare for a shutdown; it then waits for the amount time set in the <i>Power Off Delay</i> field to give the OS time to close down before the computer is powered down to standby mode.</p> <p>Likewise, when the Outlet is turned On, the eco PDU waits for the amount time set in the <i>Power On Delay</i> field, then sends an Ethernet message to the computer connected to the Outlet telling the computer to turn itself On.</p> <p>Note: For Safe Shutdown and Restart, the computer must be running Windows (98 or higher), or Linux, and the <i>Safe Shutdown</i> program (available by download from our website), must be installed and running on the computer.</p> <p>System after AC Back: This is a Safe Shutdown and Restart option. If this is selected, when an Outlet is turned Off, the eco PDU first sends a message to the computer telling it to prepare for a shutdown; it then waits for the amount time set in the <i>Power Off Delay</i> field to give the OS time to close down before the computer is powered down.</p> <p>When the Outlet is turned On, the eco PDU waits for the amount time set in the <i>Power On Delay</i> field, then sends power to the server. When the server receives the power, it turns itself on.</p> <p>Note: For Safe Shutdown and Reboot, the computer must be running Windows (98 or higher), or Linux, and the <i>Safe Shutdown</i> program (available by download from our website), must be installed and running on the computer.</p> <p>Kill the Power: If this option is selected, the eco PDU waits for the amount time set in the <i>Power Off Delay</i> field, and then turns the Outlet's power Off. Turning the power off performs a cold (non-safe) shutdown.</p> <p>◆ MAC Address: In order to use either of the Safe Shutdown and Restart methods the MAC address of the computer connected to the outlet must be filled in here.</p>

Heading	Meaning
Holiday Mode	<p>Use this drop-down menu to select the outlet's Holiday Mode. When Holiday Mode is enabled, each outlet will be set to the selection chosen for it: POWER OFF or POWER ON.</p> <p>When Holiday Mode is disabled, the outlets return to the outlet status setting before Holiday Mode was enabled.</p> <p>To enable/disable Holiday Mode, press and hold Power Control Button (8) in for more than 8 seconds. This is a toggle setting.</p>

When you have finished making your configuration settings, click **Save**.

Heartbeat

The Heartbeat page helps you to monitor the connected devices by setting your target device(s) to send the data packet to the eco PDU. You can define the mechanisms to instruct the eco PDU Power Controller to monitor the connected device(s) and control when the outlet(s) is rebooted.

The screenshot shows the ATEN PE8208AV web interface. The top navigation bar includes 'Energy', 'User', 'Log', 'Setup', and 'PDU' tabs. The main content area is titled 'Heartbeat Monitor' and features a table with columns for 'Target Name', 'IP Address', and 'Outlet No.'. A '+ Create Target' button is located in the top right corner of the table area. Below the table, the text 'No Scheduler Event' is displayed.

Make sure to install the ATEN utility, Power Monitor, to your PC before configuring Heartbeat Monitor settings. You can download the Power Monitor installer from the Support and Downloads tab of the product page.

OS	Description	Ver.	Release Date	File Name
IP Installer				
	IP Installer	v1.4.132	2012-02-10	IPInstaller-ALTUSEN_v1.4.132.zip
MIB File				
	PE568 MIB File	v1.2.113	2024-12-20	PE568_MIB_v1.2.113.zip
	PE MIB File	v1.1.115	2015-05-05	PE_MIB_File_v1.1.115.zip
	PE MIB File	v1.1.112	2014-06-19	PE8_MIB_File_v1.1.112.tar
	PE MIB File	v1.1.109	2013-09-06	PE8_MIB_File_v1.1.109.tar
	PE MIB File	v1.0.063	2012-02-10	PE8_MIB_File_v1.0.063.zip
Other				
Linux	PMonitor	v1.1	2012-02-10	PowerMonitor_v1.1.zip
Windows	PMonitor	v1.0.081	2012-02-10	PMonitorSrv_v1.0.081.zip

Create a New Target

To create a new target, click on the **+Create Target** button to enter Create Target page, and fill in the following fields:

← Create Target

Target Name

Action Reboot Outlet time(s)

Interval (sec)

Target Reboot Duration (sec)

Timeout Threshold (counts)

IP Address

Item	Description
Target Name	Enter the name for the target device.
Action	Select the outlet to be rebooted, and define how many times you'd like to reboot the selected outlet. "None" means no outlet will be rebooted.
Interval (sec)	Set the period between two data packets receive events.
Target Reboot Duration (sec)	Set the delay time to instruct the eco PDU to wait after the selected outlet is successfully rebooted. The eco PDU will not start to receive data packets from the target device till the delay time is reached.
Timeout Threshold (counts)	Determine the number of times that the eco PDU performs the action "Interval (sec)" and receives no data packets before rebooting the selected outlet.
IP Address	Enter the IP address of the target device.
Cancel / Save	Click on Save button to finish your settings, or click on Cancel button to discard the changes.

Save your settings, and now the target is created and listed on the Heartbeat Monitor list.

Heartbeat Monitor

+ Create Target

Target Name	IP Address	Outlet No.		
TEST	10.3.52.50	1	Online	<input checked="" type="checkbox"/>

Monitor, Edit, and Delete a Target

Heartbeat Monitor list delivers the following information:

Item	Description
Target Name	The name of the target device
IP Address	The IP address of the target device
Outlet No.	The outlet you selected to reboot once the criteria are triggered
Online / Offline	The status of the target device
Switch	The switch button to enable or disable the control and monitoring mechanisms

To edit or delete a target, click on the target to be edited to enter the *Edit Target* page.

← **Edit Target** Delete

Target Name

Action Reboot Outlet [01] 1 time(s)

Interval (sec)

Target Reboot Duration (sec)

Timeout Threshold (counts)

IP Address

Cancel
Save

On the *Edit Target* page, you may:

- ◆ Make changes of the settings and click on **Save** button to apply the changed settings.
- ◆ Click on **Cancel** button to discard your changed settings.
- ◆ Click on **Delete** button to remove the target from *Heartbeat Monitor* list.

Autoping

Autoping Monitoring defines the mechanism which the eco PDU uses to ping a device and to reboot the outlet. To enable this setting, you need to create a new target first.

The screenshot displays the ATEN PE8208 web interface. The top navigation bar contains icons for Energy, User, Log, Setup, and PDU. Below the navigation bar, the breadcrumb trail reads 'Connections | Configuration | Heartbeat | Autoping'. On the left, a 'Station List' shows a tree view with 'PE8208' expanded to show outlets 01 through 08. The main content area is titled 'AutoPing' and 'Autoping Monitoring'. It features a table with columns 'Target Name', 'IP Address', and 'Outlet No.'. The table is currently empty, with a message 'No Scheduler Event' centered below it. A '+ Create Target' button is located in the top right corner of the table area. The footer of the page reads 'ATEN International Co., Ltd. All rights reserved.'

Create a New Target

To create a new target, click on the **+Create Target** button to enter *Create Target* page, and fill in the following fields:

← Create Target

Target Name

Action Reboot Outlet None time(s)

Interval (sec)

Target Reboot Duration (sec)

Timeout Threshold (counts)

IP Address

MAC Address(Optional)

Item	Description
Target Name	Enter the name for the target device.
Action	Enter the maximum number of times that the eco PDU reboots the outlet of the target device after the consecutive pings. "None" means no outlet will be rebooted.
Interval (sec)	Enter the number of seconds to elapse between each auto-ping that is sent to test the network device.
Target Reboot Duration (sec)	Set the delay time to instruct the eco PDU to wait after the target outlet is successfully rebooted. The eco PDU will not start to ping the target device till the delay time is reached.
Timeout Threshold (counts)	Determine the number of times that the eco PDU performs the action "Interval (sec)" and gets no feedback from the target device before rebooting the target outlet.
IP Address	Enter the IP address of the device you want to ping.
Cancel / Save	Click on Save button to finish your settings, or click on Cancel button to discard the changes.

Once the autoping target is created, it is listed on the Autoping Monitoring list with the following information displayed:

AutoPing

Autoping Monitoring + Create Target

Target Name	IP Address	Outlet No.		
autoping 1	10.3.50.47	1	Online	<input checked="" type="checkbox"/>

Item	Description
Target Name	The name of the target device
IP Address	The IP address of the target device
Outlet No.	The outlet you selected to reboot once the criteria are triggered
Online / Offline	The status of the target device
Switch	The switch button to enable or disable the control and monitoring mechanisms

Monitor, Edit, and Delete a Target

To edit or delete a target, click on the target to be edited to enter the *Edit Target* page. On the *Edit Target* page, you may:

- ◆ Make changes of the settings and click on **Save** button to apply the changed settings.
- ◆ Click on **Cancel** button to discard your changed settings.
- ◆ Click on **Delete** button to remove the target from *Heartbeat Monitor* list.

User

When you select the *User* tab the screen comes up with *Administrator Information* and *User Information* displayed in the main panel. The eco PDU supports one Administrator account and up to eight User accounts.

- Note:**
1. Each account can support 2 login sessions.
 2. The eco PDU supports a total of 3 concurrent login sessions.

Administrator information

Administrator:

Name: Password:

SNMPv3 account information

Name: Auth-password: Priv-Passwd:

SNMPv1/v2c community

Read community: Write community:

Telnet

Name: Password:

SSH

Name: Password:

User information

Management	Name	Password	Outlet									
			All	01	02	03	04	05	06	07	08	
Enable ▾	123456	*****										
Disable ▾												
Disable ▾												
Disable ▾												
Disable ▾												
Disable ▾												
Disable ▾												
Disable ▾												

Note: There is a pre-installed administrator account. It can be used to set up the device and to begin creating users. The Username for this account is *administrator*; the password is *password*. For security purposes, we strongly recommend changing these to something unique.

Administrator Information

This section is used to set the Administrator name and password. Only Administrators can view this section. For details, see *Changing the Administrator Login*, page 28.

SNMPv3 Account Information

- ◆ Enter values for **Name**, **Auth-Password** and **Priv-Password** for SNMPv3 authentication, if required.

SNMPv1/v2c Community

- ◆ Enter values **Read community** and **Write community** for SNMPv1/V2c authentication, if required.

Telnet

- ◆ Use the Name and *Password* fields to change the account used to login via Telnet sessions.

SSH

- ◆ Enter values in the required fields to change the account used to login via SSH.

Click *Save* to save your settings.



User Information

To add a user, do the following:

1. Select the Enable or Disable in the Management drop-down menu.
2. Key in a name and password in the Name and Password fields.
3. Set the outlet-by-outlet permissions of the user in the Outlet field.
4. Click *Save* to save your settings.

Note: Values must be entered in both the Name and Password fields in order to enable an account.

The various options are explained in more detail in the following table:

Field	Description	
Management	The Management field allows you to Enable or Disable a user's account: <ul style="list-style-type: none"> ◆ Enable – stores the user account (see <i>User Information</i>, page 49) ◆ Disable – disables the user account 	
Name	From 1 to 16 characters are allowed depending on the Account Policy settings. See <i>Account Policy</i> , page 64.	
Password	From 1 to 16 characters are allowed depending on the Account Policy settings. See <i>Account Policy</i> , page 64.	
Outlet	This field allows you to set the outlet-by-outlet permissions of the user. Click on the user/port icon to cycle through the three permissions options, as follows:	
		User has complete access to this outlet.
		User has read-only access to this outlet.
		User has no access to this outlet.
Save	Click this button to save your operation or changes	

When you have finished making your configuration settings, click **Save**.

Log

The *Log* tab keeps a record of transactions that take place on its installation, and stores up to 128 events at one time. The *System Log* page provides a powerful array of filters and functions that allow you to view and export the log file data, as well as be informed by email of specified events as they occur.

No.	Date/Time	Category	Severity	User	Description
00001	2025-01-19 18:40:01	Authentication	Information	administrator	administrator 10.3.66.84 logged in
00002	2025-01-19 17:57:21	Authentication	Information	administrator	administrator 10.3.66.84 session timed out
00003	2025-01-19 17:38:44	Authentication	Information	administrator	administrator 10.3.66.84 logged in
00004	2025-01-19 17:37:24	Authentication	Information	administrator	administrator 10.3.52.39 session timed out
00005	2025-01-19 17:18:23	Authentication	Information	administrator	administrator 10.3.52.39 session timed out
00006	2025-01-19 17:17:44	Authentication	Information	administrator	administrator 10.3.52.39 logged in
00007	2025-01-19 17:05:03	System	Notification		Firmware upgrade on station 1 failed (Code: -4)
00008	2025-01-19 17:04:59	System	Information	administrator	Firmware upgrade by administrator started
00009	2025-01-19 17:04:18	Authentication	Information	administrator	administrator 10.3.52.39 logged in
00010	2025-01-19 16:03:31	Device	Warning		Outlet 2 current (0.00) min threshold warning between 0.0 ~ 1.5
00011	2025-01-19 16:03:31	Device	Warning		Outlet 1 current (0.00) min threshold warning between 0.0 ~ 1.5
00012	2025-01-19 16:03:27	System	Notification		PDU get new IP address 10.3.52.59 from DHCP server
00013	2025-01-19 16:03:25	System	Information		Device was rebooted
00014	2025-01-19 15:55:13	Authentication	Information	administrator	administrator 10.3.52.39 logged in
00015	2025-01-19 15:28:40	Authentication	Information	administrator	administrator 10.3.66.84 logged in
00016	2025-01-19 14:43:59	Authentication	Information	administrator	administrator 10.3.66.84 session timed out
00017	2025-01-19 14:31:55	System	Information	administrator	Security settings were modified by administrator
00018	2025-01-19 14:31:08	Authentication	Information	administrator	administrator 10.3.66.84 logged in

The System Log Event List

- ◆ Clicking on a device in the Sidebar displays its log events in the main panel's log event list.
- ◆ Clicking the **Refresh** button brings the log list up to date with the latest events.
- ◆ The entry box to the right of the Refresh button lets you set the number of events to display per page. Simply key in the number of your choice.
- ◆ The top right of the main panel shows the total number of pages in the log file, and what page you are currently viewing.
- ◆ The buttons on the bottom row function as follows:
 - ◆ **Clear**: click to erase the contents of the log event list
 - ◆ **First Page**: click to go to the first page of the log event list

- ◆ **Previous Page:** click to move to the previous page of the log event list
- ◆ **Next Page:** click to move to the next page of the log event list
- ◆ **Last Page:** click to move to the last page of the log event list
- ◆ **Save:** Click to save the contents of the log event list to file. Select .csv or .txt type, can click **Save**.

Select the type of file to export the logs.

.Csv File
 .Txt File

Notification Settings

The *Notification Settings* page is used to specify which of the eco PDU's components will receive notification of a log event. When you click the Notification Settings menu item, a page similar to the one below appears:

Event Log Settings

Event List	Syslog	E-mail	SNMP
> Enable all system events	✓	✓	✓
∨ Enable all Authentication events	✓	✓	✓
User login	✓	✓	✓
User login failure	✓	✓	✓
User logout	✓	✓	✓
Session timeout	✓	✓	✓
User locked	✓	✓	✓
User unlocked	✓	✓	✓
∨ Enable all User Management events	✓	✓	✓
Outlet port setting modified	✓	✓	✓
User added	✓	✓	✓
User deleted	✓	✓	✓
User account modified	✓	✓	✓
User access right(outlet) modified	✓	✓	✓
External authentication failed	✓	✓	✓
> Enable all Device Management events	✓	✓	✓

- ◆ The event categories are listed in the left column.
- ◆ When you first open the page, only the main category items appear. (Main category item rows have a gray background.)

- ◆ Sub-category items are nested under the main category headings. Click the arrow in front of the main category headings to display the subcategory items. (Sub-category item rows have a white background.)
- ◆ Click the checkboxes under the column headings to select which component(s) will receive notification of the log events.
 - ◆ Clicking on a main category heading's row automatically selects all the sub-category items nested below it.
 - ◆ If you only want to set notification for some of the sub-category events, don't put a check in the main category row. Instead, drop down the sub-category list, and only check the sub-category events you want.
- ◆ When you have finished making your setting choices, click Save. When a specified log event occurs, notification of that event will be sent to the selected component.
- ◆ Reset Digital Output: If an event has been triggered that changes the digital output sensor from Low to High, click this button to return the sensor to the Low state.

When you have finished making your configuration settings, click **Save**.

Setup

The *Setup* tab provides Device Configuration and Security settings. The *Device Configuration* page allows administrators to configure eco PDU system settings. The *Security* page controls access to the PDU.

Device Configuration

This page presents information about the selected device, as described in the following sections:

General

General

PDU Name:

MAC Address: 00:10:74:DC:03:05

Firmware Version: 9.0.061

Serial Number: 123456789

Rack Location name:

Item	Meaning
PDU Name	This field lets you give the device a unique name. Simply delete whatever is in the text box and key in the name of your choice. Click Save (located at the bottom of the page) to save the new name.
MAC Address	This item displays the eco PDU's MAC address.
Firmware Version	This item displays the current firmware version number. You can reference it to see if there are newer versions available on the website.
Rack Location Name	This field lets you give the rack location a unique name for easy reference.

Service Ports

As a security measure, if a firewall is being used, the Administrator can specify the port numbers that the firewall will allow. If a port other than the default is used, users must specify the port number as part of the IP address when they log in. If an invalid port number (or no port number) is specified, the eco PDU will not be found.

Select whether to allow only secure browser logins, as show below:

Service Ports

Only HTTPs HTTP / HTTPs

HTTP:

HTTPS:

An explanation of the fields is given in the table below:

Field	Explanation
HTTP	The port number for a browser login. The default is 80.
HTTPS	The port number for a secure browser login. The default is 443.

Note: 1. Valid entries for all of the Service Ports are from 1–65535.

2. The service ports cannot have the same value. You must set a different value for each one.
3. If there is no firewall (on an Intranet, for example), it doesn't matter what these numbers are set to, since they have no effect.

IPv4 Configuration

The PDU's IPv4 IP and DNS addresses (the traditional method of specifying IP addresses) can either be assigned dynamically (DHCP), or a fixed IP address can be specified.

IPv4 Configuration

Ethernet1

Obtain IP address automatically [DHCP]

Set IP address manually [Fixed IP]

IP Address:

Subnet Mask:

Default Gateway:

Obtain DNS server address automatically

Set DNS server address manually

Preferred DNS Server:

Alternate DNS Server:

- ◆ For dynamic IP address assignment, select the *Obtain IP address automatically* radio button. (This is the default setting.)
- ◆ To specify a fixed IP address, select the *Set IP address manually* radio button and fill in the IP address with values appropriate for your network.
- ◆ For automatic DNS Server address assignment, select the *Obtain DNS Server address automatically* radio button.
- ◆ To specify the DNS Server address manually, select the *Set DNS server address manually* radio button, and fill in the addresses for the Preferred and Alternate DNS servers with values appropriate for your network.

-
- Note:**
1. If you choose *Obtain IP address automatically*, when the device starts up it waits to get its IP address from the DHCP server. If it hasn't obtained the address after one minute, it automatically reverts to its factory default IP address (192.168.0.60.)
 2. If the device is on a network that uses DHCP to assign network addresses, and you need to ascertain its IP address, see *IP Address Determination*, page 93, for information.
 3. Specifying the Alternate DNS Server address is optional.
-

IPv6 Configuration

The eco PDU's IPv6 IP and DNS addresses (the traditional method of specifying IP addresses) can either be assigned automatically (DHCP), or manually, by specifying a fix IP address.

IPv6 Configuration

Ethernet1

Enable autoconfiguration

Set configuration manually

IP Address:

Static Prefix Length:

Default Gateway:

Use DHCPv6 to obtain DNS Server Addresses

Set DNS server address manually

Preferred DNS Server:

Alternate DNS Server:

- ◆ For dynamic IP address assignment, select the *Enable autoconfiguration* radio button. (This is the default setting.)
- ◆ To specify a fixed IP address, select the *Set configuration manually* radio button and fill in the IP address with values appropriate for your network.
- ◆ For automatic DNS Server address assignment, select the *Use DHCPv6 to obtain DNS Server Addresses* radio button.
- ◆ To specify the DNS Server address manually, select the *Set DNS server address manually* radio button, and fill in the addresses for the Preferred and Alternate DNS servers with values appropriate for your network.

-
- Note:**
1. If you choose *Obtain IP address automatically*, when the device starts up, it shall wait for its assigned IP address from the DHCP server. If it hasn't obtained an IP address after one minute, it automatically reverts to its default IP address (192.168.0.60.)
 2. If the device is on a network that uses DHCP to assign network addresses, and you need to ascertain its IP address, see *IP Address Determination*, page 117.
 3. Specifying the Alternate DNS Server address is optional.
-

Event Notification

The Event Notification section is divided into three sections: SMTP Server; SNMP Trap Receivers; and Syslog Server. Each section is described below.

◆ SMTP Server

The screenshot shows the 'Event Notification' configuration page. The 'SMTP Server' section is active. It contains the following fields and options:

- Enable report from the following SMTP Server
- SMTP Server: [Redacted]
- SMTP Port Number: 25
- Server requires authentication
- Account Name: [Redacted]
- Password: [Redacted]
- Enable secure connection (STARTTLS)
- From: [Redacted]
- To: [Redacted]

To have the eco PDU email reports from the SMTP server to you, do the following:

1. Enable the *Enable report from the following SMTP Server*, and key in the IP address and Port number of your SMTP server.
2. If your server requires authentication, put a check in the *My server requires authentication* checkbox.
3. Key in the appropriate account information in the *Account Name*, *Password*, and *From* fields.

Note: Only one email address is allowed in the *From* fields, and it cannot exceed 64 characters.

4. Key in the email address (addresses) of where you want the event reports sent to in the *To* field.

Note: If you are sending the report to more than one email address, separate the addresses with a semicolon. The total cannot exceed 256 characters.

◆ SNMP Trap Receivers

SNMP Trap Receiver

Enable SNMP Trap
 SNMPv3
 SNMPv2c
 SNMPv1

Receiver IP 1:

Service Port 1:

Community 1:

User name 1:

Auth-password 1:

Priv-Password 1:

Receiver IP 2:

Service Port 2:

Community 2:

User name 2:

Auth-password 2:

Priv-Password 2:

Up to four SNMP management stations can be specified. If you want to use SNMP trap notifications, do the following:

1. Check *Enable SNMP Trap*.
2. Select which version of SNMP you want to use.
3. Key in the IP address(es) and the service port number(s) of the computer(s) to be notified of SNMP trap events. The valid port range is 1–65535. The default port number is 162.

Note: Make sure that the port number you specify here matches the port number used by the SNMP receiver computer.

4. Key in the community value(s) if required for the SNMP version.
5. Key in the auth/privacy password(s) that correspond to each of the stations.

Syslog Server

Syslog Server

Enable Syslog Server

Server IP:

Service Port:

To record all the events that take place on eco PDU devices and write them to the eco PDU Syslog server, do the following:

1. Check **Enable Syslog Server**.
2. Key in the IP address and the port number of the Syslog server. The valid port range is 1-65535. The default port number is 514.

Date/Time

The Date/Time dialog page sets the eco PDU time parameters:

Date Time

Time Zone

(UTC-12:00) Eniwetok Kwajalein

Daylight Savings Time

Manually Input

Date: 2025-01-19 (YYYY-MM-DD)

Time: 19:54:14 (HH:MM:SS)

Sync with PC

Network Time

Enable auto adjustment

AU | ntp1.cs.mu.OZ.AU

Preferred custom server IP:

Alternate time server:

AU | ntp1.cs.mu.OZ.AU

Alternate custom server IP:

Sync time every: 1 Day

Adjust Time Now

Time Zone

- ◆ To establish the time zone that the eco PDU is located in, drop down the *Time Zone* list and choose the city that most closely corresponds to where it is at.
- ◆ If your country or region employs Daylight Saving Time (Summer Time), check the corresponding checkbox.

Manual Input

Use this section to specify the eco PDU's date and time manually.

- ◆ Click the calendar icon and click the calendar entry for the date.
- ◆ Key the time into the Time field, using the HH:MM:SS (hours, minutes, seconds) format.

Note: This section is only enabled when *auto adjustment* (in the *Network Time* section) is disabled (the checkbox is unchecked).

As an alternative to specifying the date and time by entering them into the date and time fields, you can click to put a check in the *Sync with PC* checkbox, in which case the eco PDU will take its date and time settings from the locally connected PC.

Network Time

To have the time automatically synchronized to a network time server, do the following:

1. Check the *Enable auto adjustment* checkbox.
2. Drop down the time server list to select your preferred time server
– or –

Check the *Preferred custom server IP* checkbox, and key in the IP address of the time server of your choice.

3. If you want to configure an alternate time server, check the *Alternate time server* checkbox, and repeat step 2 for the alternate time server entries.
4. Key in your choice for the number of days between synchronization procedures.

Finishing Up

When you have finished making your settings on this page, click **Save**.

After you have saved your changes, if you want to synchronize immediately, click **Adjust Time Now**.

Security

The *Security* page controls access to the eco PDU device.

Security

Login Failures

Allowed:

Timeout: min

Working Mode

Enable Telnet Server
 Disable Telnet authentication
 Enable Modbus
 Enable SSH

TLS Support

Enable TLS1.0/TLS1.1

IPInstaller Setting

Disable Read-only Read-write

Session Timeout

Enable Web Session Timeout in Minute(s)

Login Failures

- ◆ **Allowed** sets the number of consecutive failed login attempts that are permitted from a remote user.
- ◆ **Timeout** sets the amount of time a remote user must wait before attempting to login again after exceeding the number of allowed failures.

Working Mode

- ◆ If *Enable ICMP* is checked, the eco PDU device can be pinged. If it is not enabled, the device cannot be pinged. The default is Enabled.

- ◆ If *Enable Telnet Server* is checked, the PDU is accessible via a Telnet sessions using the Telnet username and password (see *Telnet*, page 49)

IP Installer Setting

- ◆ If *Disable* is checked, the IP address of the eco PDU cannot be found by the IP Installer software.
- ◆ If *Readonly* is checked, the IP address of the eco PDU can be found but not configurable by the IP Installer software.
- ◆ If *Read-write* is checked, the IP address of the eco PDU can be found and configurable by the IP Installer software.

Session Timeout

- ◆ If *Enable Web Session Timeout in* is checked, a user's web session will logout due to inactivity after the number of *Minute(s)* entered (1–5) is surpassed.

Account Policy

The Account Policy section governs policies in regard to usernames and passwords.

Account Policy

Minimum Username Length:

Minimum Password Length:

Password Must Contain at Least:

One Upper Case
 One Lower Case
 One Number

Disable Duplicate Login

Check a policy and enter the required information in the appropriate fields.

Item	Description
Minimum Username Length	Sets the minimum number of characters required for a username. Acceptable values are from 1–16.
Minimum Password Length	Sets the minimum number of characters required for a password. Acceptable values are from 1–16.

Item	Description
Password Must Contain At Least	Checking any of these items requires users to include at least one of the specified items in their password. Note: This policy does not affect existing user accounts. Only new user accounts created after this policy has been enabled, and users required to change their passwords are affected.
Disable Duplicate Login	Check this to prevent users from logging in with the same account at the same time.

IP Filter / Mac Filter

If any filters have been configured, they appear in the IP Filter and/or MAC Filter list boxes.

IP and MAC Filters control access to the eco PDU based on the IP and/or MAC addresses of the client computers attempting to connect. A maximum of 5 IP filters and 5 MAC filters are allowed.

To enable IP and/or MAC filtering, click to put a check mark in the *IP Filter Enable* and/or *MAC Filter Enable* checkbox.

- ◆ If the include button is checked, all the addresses within the filter range are allowed access; all other addresses are denied access.

IP Filter/MAC Filter

IP Filter Enable
 Include
 Exclude

Add

Modify

Delete

MAC Filter Enable
 Include
 Exclude

Add

Modify

Delete

◆ Adding Filters

To add an IP filter, do the following:

1. Click **Add**. A dialog box similar to the one below appears:

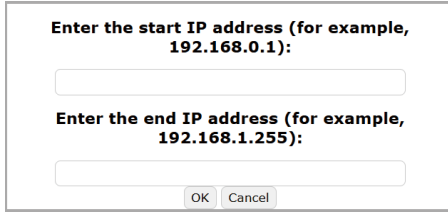

The dialog box has a title bar and contains the following text and elements:

- Text: **Enter the start IP address (for example, 192.168.0.1):**
- Input field: A rectangular text box for entering the start IP address.
- Text: **Enter the end IP address (for example, 192.168.1.255):**
- Input field: A rectangular text box for entering the end IP address.
- Buttons: **OK** and **Cancel** buttons at the bottom right.

2. Specify the start filter address in the dialog box (for example, 192.168.0.200), then click **OK**.
3. To filter a single IP address, key in the same address as the start IP. To filter a continuous range of addresses, key in the end number of the range (for example, 192.168.0.225).
4. After filling in the address, click **OK**.

Repeat these steps for any additional IP addresses you want to filter.

To add a MAC filter, do the following:

1. Click **Add**. A dialog box similar to the one below appears:

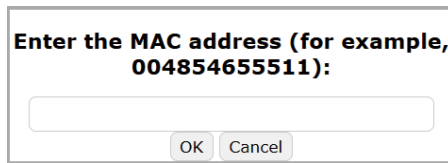

The dialog box has a title bar and contains the following text and elements:

- Text: **Enter the MAC address (for example, 00485465511):**
- Input field: A rectangular text box for entering the MAC address.
- Buttons: **OK** and **Cancel** buttons at the bottom right.

2. Specify the MAC address in the dialog box (for example, 001074670000), then click **OK**.

Repeat these steps for any additional MAC addresses you want to filter.

◆ **IP Filter / MAC Filter Conflict**

If there is a conflict between an IP filter and a MAC filter—for example, where a computer’s IP address is allowed by the IP filter but its MAC address is excluded by the MAC filter—then that computer’s access is blocked.

In other words, if either filter blocks a computer, then the computer is blocked, no matter what the other filter is set to.

- ◆ **Modifying Filters**

To modify a filter, select it in the IP Filter or MAC Filter list box and click **Modify**. The Modify dialog box is similar to the Add dialog box. When it comes up, simply delete the old address(es) and replace it with the new one(s).

- ◆ **Deleting Filters**

To delete a filter, select it in the IP Filter or MAC Filter list box and click **Delete**.

Authentication & Authorization

The Authentication & Authorization page is used to set up login authentication and authorization management from external sources.

Authentication & Authorization

Auth Type:

RADIUS

RADIUS Settings

Preferred RADIUS Server IP:

Preferred RADIUS Service Port:

1812

Alternate RADIUS Server IP:

Alternate RADIUS Server Port:

1645

Timeout:

3

Retries:

3

Shared Secret (at least 6 characters):

RADIUS Settings

To allow authentication and authorization for the eco PDU device through a RADIUS server, do the following:

1. Check **Enable**.
2. Fill in the IP addresses and service port numbers for the Preferred and Alternate RADIUS servers. The default port number for the Preferred server is 1812; the default port number for the Alternate server is 1645.

Note: Make sure that the port numbers you specify here match the port numbers used by the RADIUS servers.

3. In the *Timeout* field, set the time in seconds that the eco PDU device waits for a RADIUS server reply before it times out.
4. In the *Retries* field, set the number of allowed retries for attempting to connect to the RADIUS server.
5. In the *Shared Secret* field, key in the character string that you want to use for authentication between the eco PDU device and the RADIUS Server.

6. On the RADIUS server, set the entry for each user as follows:

`su/administrator` or `su/user`

Where `xxxx` represents the Username given to the user when the account was created on the eco PDU device. The user's access rights are the ones assigned for the eco PDU device, as well. (See *User Information*, page 49.)

Note: `su/user` supports view ports only; `su/administrator` supports all eco PDU functions.

LDAP Settings

To allow authentication and authorization for the eco PDU device through a LDAP server, do the following:

1. Use the drop-down menu and select **LDAP**.
2. Select a Type of LDAP Server and Security option and fill in the IP addresses/hostname, port numbers, Bind DN, Password, Login Name Attribute, Base DN, User entry object class, and Login Attribute for the LDAP servers. The default port number is 389.

Note: Make sure that the port numbers you specify here match the port numbers used by the LDAP servers.

3. In the *Timeout* field, set the time in seconds that the eco PDU device shall wait for the LDAP server to reply before it times out. The default timeout is 3 seconds.
4. On the LDAP server, set the entry for each user as follows:

`su/xxxx`

Where `xxxx` represents the username given to the user when the account was created on the eco PDU device. The user's access rights equivalent to the ones assigned for the eco PDU device. (See *User Information*, page 49.)

Note: `su/user` supports view ports only; `su/administrator` supports all eco PDU functions.

TACACS+ Settings

To allow authentication and authorization for the eco PDU device through a TACACS+ server, do the following:

1. Use the drop-down menu and select **TACACS+**.
2. Fill in the IP addresses and service port numbers for the Preferred and Alternate TACACS+ servers. The default port number for the Preferred server is 49; the default port number for the Alternate server is 49.

Note: Make sure that the port numbers you specify here match the port numbers used by the TACACS+ servers.

3. In the *Timeout* field, set the time in seconds that the eco PDU device shall wait for the TACACS+ server to reply before it times out. The default timeout is 3 seconds.
4. In the *Retries* field, set the number of allowed retries for attempting to connect to the TACACS+ server. The default retries is 3 times.
5. In the *Shared Secret* field, key in the character string that you want to use for authentication between the eco PDU device and the TACACS+ Server.
6. On the TACACS+ server, set the entry for each user as follows:

su/xxxx

Where *xxxx* represents the username given to the user when the account was created on the eco PDU device. The user's access rights equivalent to the ones assigned for the eco PDU device. (See *User Information*, page 49.)

Note: su/user supports view ports only; su/administrator supports all eco PDU functions.

Private Certificate

When logging in over a secure (SSL) connection, a signed certificate is used to verify that the user is logging in to the intended site. For enhanced security, the *Private Certificate* section allows you to use your own private encryption key and signed certificate, rather than the default ATEN certificate.

Private Certificate

Private Key:

Certificate:

There are two methods for establishing your private certificate: generating a self-signed certificate; and importing a third-party certificate authority (CA) signed certificate.

Generating a Self-Signed Certificate

If you wish to create your own self-signed certificate, a free utility—`openssl.exe`—is available for download over the web.

Obtaining a CA Signed SSL Server Certificate

For the greatest security, we recommend using a third party certificate authority (CA) signed certificate. To obtain a third party signed certificate, go to a CA (Certificate Authority) website to apply for an SSL certificate. After the CA sends you the certificate and private encryption key, save them to a convenient location on your computer. Importing the Private Certificate To import the private certificate, do the following:

1. Click **Browse** to the right of *Private Key*; browse to where your private encryption key file is located; and select it.
2. Click **Browse** to the right of *Certificate*; browse to where your certificate file is located; and select it.
3. Click **Upload** to complete the procedure.

Note: 1. Clicking **Restore Default** returns the device to using the default ATEN certificate.

2. Both the private encryption key and the signed certificate must be imported at the same time.
-

When you have finished making your settings on this page, click **Save**.

Rules

The Rules page allows you to manage and set rules for the eco PDU in your installation.

Add a New Rule

To add a new rule, do the following:

The image shows three sequential screenshots of the 'Rules' configuration page. The first screenshot shows the 'Add' button highlighted with a red circle and the number 1. The second screenshot shows the 'Detail' button highlighted with a red circle and the number 2. The third screenshot shows the 'Save' button highlighted with a red circle and the number 3, and the 'Add' button highlighted with a red circle and the number 4. The third screenshot also shows a table with columns for Station, Source, Source Index, Event, and Delete, and a table with columns for Sequence, Station, Target, Target Index, Action, and Delete.

Rules

Enable Name Detail Delete

Add **1**

Rules

Enable Name Detail Delete

Rule1 > **2**

Add

Rules

Enable Name Detail Delete

Rule1 v

Station	Source	Source Index	Event	Delete
1	Device	1	Current Over	

Add **2a**

Sequence	Station	Target	Target Index	Action	Delete
1	1	Device	1	Turn Off	

Add **2b**

Add **4**

3 Save

1. Click on the *Add* button to continue.
2. Click the Detail button to expand the fields to specify the rule.
 - a) To add more station, click *Add*.
 - b) To add more sequence, click *Add*.
3. Click on the Save button to finish.
4. To add more rules, repeat the aforementioned steps.

Edit the Rules

You can edit the rules using the elements:

The screenshot shows a 'Rules' configuration window. It contains two rule entries, 'Rule1' and 'Rule2'. 'Rule1' is selected and expanded to show its configuration details. Red callouts point to the following elements:

- 1**: The 'Enable' checkbox for Rule1.
- 2**: The 'Name' field for Rule1.
- 3**: The 'Detail' icon (downward arrow) for Rule1.
- 4**: The 'Delete' icon (trash bin) for Rule1.
- 5**: The 'Add' button for adding a new Station Source.
- 5**: The 'Add' button for adding a new Sequence Station.
- 5**: The 'Add' button for adding a new Rule.
- 6**: The 'Save' button at the bottom right of the window.

The configuration details for Rule1 are as follows:

Station	Source	Source Index	Event	Fluctuation	Target	Action	Delete
1	Device	1	Current Over	0	A	Fluctuation 0	A
AND							
1	Device	1	Current Over	0	A	Fluctuation 0	A
AND							
1	Device	1	Current Over	0	A	Fluctuation 0	A

Sequence	Station	Target	Target Index	Action	Delete
1	1	Device	1	Turn Off	
2	1	Device	1	Turn Off	
3	1	Device	1	Turn Off	

No.	Item	Description
1	Enable	Check to enable the rule you configured for your eco PDU.
2	Name	Enter the name for the rules.
3	Detail	Click to bring up more options to configure the rules.
4	Delete	Click the bin icon to remove the rules.
5	Add	Click to add more Station Source, Sequence Station, or Rules.
6	Save	Click to save the changes you just made.

Scheduler

Use the *Scheduler* page to power on, power off, or reboot the eco PDU.

Scheduler

Events + Create Event

Event Name	Frequency	Time	Days	Actions	Toggle
Reboot	Weekly	08:00	Sun	Power Reboot	<input checked="" type="checkbox"/>

Actions + Create Action

Action Name	Operation Time	Action	Outlet(s)
Power Reboot	Immediately	Power ON	outlet 01,02,03,04
Power On	Use Delay Time	Power ON	outlet 01,02,03,04
Power Off	Immediately	Power OFF	outlet 01,02,03,04

To create an event, follow the steps below.

1. Go to **Setup > Scheduler**.
2. Create one or more power-on, power-off, and/or reboot actions. These actions will be selectable when configuring an event.
 - a) Click **+Create Action**.
 - b) In the pop-up screen, name the action, and use the drop-down lists to configure the action and the target outlet(s).

← Create Action

Action Name

Action

outlets

[unselect all](#)

<input checked="" type="checkbox"/>	[01]
<input checked="" type="checkbox"/>	[02]
<input checked="" type="checkbox"/>	[03]
<input checked="" type="checkbox"/>	[04]

c) Click **Save**. The action is added to the list.

Actions			+ Create Action
Action Name	Operation Time	Action	
Power Reboot	Immediately	Power ON outlet 01,02,03,04	

3. Create an event.

a) Click **+Create Event**.

b) In the pop-up screen, name the event, and then configure the schedule and action as needed.

← Create Event

Event Name

Scheduled Time Weekly 08 : 00

Date Sun Mon Tue Wed Thu Fri Sat

Actions Add available actions

Action Name	Operation Time	Action
Power Reboot	Immediately	Power Reboot outlet 01,02,03,04

c) Click **Save**. The event is added to the event list. Use the toggle button to enable/disable created events.

Scheduler						+ Create Event
Event Name	Frequency	Time	Days	Actions		
Reboot	Weekly	08:00	Sun	Power Reboot		<input checked="" type="checkbox"/>

Actions			+ Create Action
Action Name	Operation Time	Action	
Power Reboot	Immediately	Power Reboot outlet 01,02,03,04	

Mail Control

Mail Control is to send the CLI commands by email to control the eco PDU . The default setting is disabled.

Mail Control

Enable

Control Username:

Control Password:

Approved Sender List:

Item	Description
Enable	Check the checkbox to enable mail control function.
Control Username	Define the username to perform mail control function. This field is required.
Control Password	Set the password of Control Username . This field is required.
Approved Sender List	Enter the email address(es) that is allowed to send commands through email to control the eco PDU. To add multiple senders, use a comma to separate email addresses. Please note that a space character is not accepted in the entry. Do not enter space characters between email address and comma.

Mail Client

Mail Client is to set the email address that receives the commands from the

Mail Client:

Mail Address:

Username:

Password:

approved sender(s) and sends the notification emails to the recipients on *Approved Sender List*.

Item	Description
Mail Address	Enter the address of the email account that you'd like to use to send the notification emails and receive the email(s) whose content contains commands to control the eco PDU.
Username / Password	Enter the login credentials in your email client.

Receive Mail Server

Fill in the following information to define your mail server of the email account that you set to receive the command email(s).

Receive Mail Server

Server Address:

Server Port:

IMAP
 IMAPS

POP3
 POP3S

Checking Interval (sec):

Item	Description
Server Address	Enter server address of the email provider that you use to retrieve the command email(s) from the mail server.
Server Port	Enter the port number that your email server uses.
IMAP / POP3	<p>Click the radio button to select the protocol (methods) used for accessing emails. The options are IMAP and POP3.</p> <p>To encrypt and secure the incoming mails, enable the checkbox of IMAPS / POP3S after selecting IMAP or POP3 as the protocol.</p>
Checking Interval (sec)	Set the time you'd like to check for new incoming mails automatically.

Send Mail Server

Specify the information about your outgoing email server.

Send Mail Server

Server Address:

Server Port:

SMTPS

Item	Description
Server Address	Enter the outgoing email server address of your email provider.
Server Port	Enter the port number that your email server uses.
SMTPS	Enable the checkbox to encrypt and secure the outgoing emails.

Commands Sent by Email

Once the *Mail Control* configurations are done, you are able to control the eco PDU through email(s) sent from the email address(es) on *Approved Sender List*.

The command script must be one command per line, starts with the control username and control password, and end with the command “end”.

The following is an example of email content for mail control:

```
mailadmin
mailpwd
sw o01 on
sw o02 on
sw o03 on
sw o04 on
end
```

In this example, “mailadmin” stands for the control username while “mailpwd” is the control password. Please input your control username and control password in your command script. “End” in the last line indicates that the command script ends.

PDU

The *PDU* tab is used to upgrade the eco PDU's firmware, and to backup and restore the device's configuration settings.

Upgrade Main Firmware

The *Upgrade Main Firmware* page is used to upgrade the firmware of the eco PDU.

Firmware File

When you click the **Upgrade Main Firmware** tab, the display opens with the *Firmware Upgrade* menu page, which looks similar to the one below:

Firmware File

Check Main Firmware Version

Energy Box Name	Firmware Version
PE8208 _derek [PE8208]	Firmware Version: 1.0.068

MMC version:1.3.124

Front Panel F/W Version0.0.000

Filename:

A description of the items shown in this panel are given in the table, below:

Item	Description
Check Main Firmware Version	If you enable <i>Check Main Firmware Version</i> , the eco PDU's current firmware level is compared with that of the upgrade file. If the current version is equal to or higher than the upgrade version, a popup message appears, to inform you of the situation and stops the upgrade procedure.
Name	Lists all of the eco PDU devices. Click to put a check in the checkbox of the device's whose firmware you want to upgrade.
F/W Version	Displays the eco PDU's current firmware version.
Filename	As new versions of the firmware become available, they are posted on our website and can be downloaded to a convenient location on your computer. Click the <i>Browse</i> button to select the downloaded upgrade file.
Upgrade	Click this button to upgrade the firmware of the selected devices.

■ Upgrading the Firmware

To upgrade the firmware refer to the screenshot on the preceding page, and do the following:

1. Go to our website and download the new firmware file to a convenient location on your computer.
2. Click the *Browse* button; navigate to where the firmware file is located and select it.
3. Click **Upgrade** to start the upgrade procedure.
 - ◆ If you enabled *Check Main Firmware Version* the current firmware level is compared with that of the upgrade file. If the current version is equal to or higher than the upgrade version, a popup message appears, to inform you of the situation and stops the upgrade procedure.
 - ◆ If you didn't enable *Check Main Firmware Version*, the upgrade file is installed without checking what its level is.
 - ◆ Once the upgrade completes successfully, the switch resets itself.
4. Log in again, and check the firmware version to be sure it is the new one.

■ Firmware Upgrade Recovery

Should the eco PDU's firmware upgrade procedure fail, and the device becomes unusable, the following firmware upgrade recovery procedure will resolve the problem:

1. Power off the device.
2. Press and hold the reset button.
3. While holding the Reset Switch in, power the switch back on.

This causes the switch to use the original factory installed main firmware version. Once the switch is operational, you can try upgrading the main firmware again.

Backup/Restore

Selecting *Backup/Restore* on the menu bar gives you the ability to back up the switch's configuration and user profile information:

Station List

Energy Box Name	Filename
PE8208 _derek [PE8208]	please select a file to restore ▾

Backup

Password:

Restore

Auto Mapping

Password:

Filename:

Backup

To backup the device's settings do the following:

1. In the *Password* field, key in a password for the file.

Note: Entering a password is optional. If you do enter a password, make a note of it, since you will need it to be able to restore the file.

2. Click **Save**.
3. When the browser asks what you want to do with the file, select *Save to disk*; then save it in a convenient location.

Restore

To restore a previous backup, do the following:

1. Click **Browse**; navigate to the file and select it.

Note: If you renamed the file, you can leave the new name. There is no need to return it to its original name.

-
2. In the *Password* field, key in the same password that you used to save the file.

Note: If you did not set a password when you created the backup file, you can omit this step.

-
-
3. Select as many of the options that are presented as you wish to restore.
4. Click **Restore**.

After the file is restored, a message appears to inform you that the procedure succeeded.

Safety Instructions

General

- ◆ This product is for indoor use only.
- ◆ Read all of these instructions. Save them for future reference.
- ◆ Follow all warnings and instructions marked on the device.
- ◆ Do not place the device on any unstable surface (cart, stand, table, etc.). If the device falls, serious damage will result.
- ◆ Do not use the device near water.
- ◆ Do not place the device near, or over, radiators or heat registers.
- ◆ The device cabinet is provided with slots and openings to allow for adequate ventilation. To ensure reliable operation, and to protect against overheating, these openings must never be blocked or covered.
- ◆ The device should never be placed on a soft surface (bed, sofa, rug, etc.) as this will block its ventilation openings. Likewise, the device should not be placed in a built in enclosure unless adequate ventilation has been provided.
- ◆ Never spill liquid of any kind on the device.
- ◆ Unplug the device from the wall outlet before cleaning. Do not use liquid or aerosol cleaners. Use a damp cloth for cleaning.
- ◆ The device should be operated from the type of power source indicated on the marking label. If you are not sure of the type of power available, consult your dealer or local power company.
- ◆ To prevent damage to your installation it is important that all devices are properly grounded.
- ◆ The device is designed for IT power distribution systems with 100V to 230V phase-to-phase voltage.
- ◆ The device is equipped with a 3-wire grounding type plug. This is a safety feature. If you are unable to insert the plug into the outlet, contact your electrician to replace your obsolete outlet. Do not attempt to defeat the purpose of the grounding-type plug. Always follow your local/national wiring codes.

- ◆ If an extension cord is used with this device make sure that the total of the ampere ratings of all products used on this cord does not exceed the extension cord ampere rating. Make sure that the total of all products plugged into the wall outlet does not exceed 15 amperes.
- ◆ The equipment should be installed near the wall socket outlet and the disconnect device (appliance coupler) should be readily accessible.
- ◆ Do not allow anything to rest on the power cord or cables. Route the power cord and cables so that they cannot be stepped on or tripped over.
- ◆ To help protect your system from sudden, transient increases and decreases in electrical power, use a surge suppressor, line conditioner, or uninterruptible power supply (UPS).
- ◆ Position system cables and power cables carefully; Be sure that nothing rests on any cables.
- ◆ When connecting or disconnecting power to hot pluggable power supplies, observe the following guidelines:
 - ◆ Install the power supply before connecting the power cable to the power supply.
 - ◆ Unplug the power cable before removing the power supply.
 - ◆ If the system has multiple sources of power, disconnect power from the system by unplugging all power cables from the power supplies.
- ◆ Never push objects of any kind into or through cabinet slots. They may touch dangerous voltage points or short out parts resulting in a risk of fire or electrical shock.
- ◆ Do not attempt to service the device yourself. Refer all servicing to qualified service personnel.
- ◆ If the following conditions occur, unplug the device from the wall outlet and bring it to qualified service personnel for repair.
 - ◆ The power cord or plug has become damaged or frayed.
 - ◆ Liquid has been spilled into the device.
 - ◆ The device has been exposed to rain or water.
 - ◆ The device has been dropped, or the cabinet has been damaged.
 - ◆ The device exhibits a distinct change in performance, indicating a need for service.
 - ◆ The device does not operate normally when the operating instructions are followed.

- ◆ Only adjust those controls that are covered in the operating instructions. Improper adjustment of other controls may result in damage that will require extensive work by a qualified technician to repair.
- ◆ Do not connect the RJ-11 connector marked "Sensor" to a public telecommunication network.

Consignes de sécurité

Général

- ◆ Ce produit est destiné exclusivement à une utilisation à l'intérieur.
- ◆ Veuillez lire la totalité de ces instructions. Conservez-les afin de pouvoir vous y référer ultérieurement.
- ◆ Respectez l'ensemble des avertissements et instructions inscrits sur l'appareil.
- ◆ Ne placez jamais l'unité sur une surface instable (chariot, pied, table, etc.). Si l'unité venait à tomber, elle serait gravement endommagée.
- ◆ N'utilisez pas l'unité à proximité de l'eau.
- ◆ Ne placez pas l'unité à proximité de ou sur des radiateurs ou bouches de chaleur.
- ◆ Le boîtier de l'unité est doté de fentes et d'ouvertures destinées à assurer une ventilation adéquate. Pour garantir un fonctionnement fiable et protéger l'unité contre les surchauffes, ces ouvertures ne doivent jamais être bloquées ou couvertes.
- ◆ L'unité ne doit jamais être placée sur une surface molle (lit, canapé, tapis, etc.) car ses ouvertures de ventilation se trouveraient bloquées. De même, l'unité ne doit pas être placée dans un meuble fermé à moins qu'une ventilation adaptée ne soit assurée.
- ◆ Ne renversez jamais de liquides de quelque sorte que ce soit sur l'unité.
- ◆ Débranchez l'unité de la prise murale avant de la nettoyer. N'utilisez pas de produits de nettoyage liquide ou sous forme d'aérosol. Utilisez un chiffon humide pour le nettoyage de l'unité.
- ◆ L'appareil doit être alimenté par le type de source indiqué sur l'étiquette. Si vous n'êtes pas sûr du type d'alimentation disponible, consultez votre revendeur ou le fournisseur local d'électricité.
- ◆ Afin de ne pas endommager votre installation, vérifiez que tous les périphériques sont correctement mis à la terre.
- ◆ L'unité est équipée d'une fiche de terre à trois fils. Il s'agit d'une fonction de sécurité. Si vous ne parvenez pas à insérer la fiche dans la prise murale, contactez votre électricité afin qu'il remplace cette dernière qui doit être obsolète. N'essayez pas d'aller à l'encontre de l'objectif de la fiche de terre. Respectez toujours les codes de câblage en vigueur dans votre région/pays.

-
- ◆ L'équipement doit être installé à proximité de la prise murale et le dispositif de déconnexion (prise de courant femelle) doit être facile d'accès.
 - ◆ Veillez à ce que rien ne repose sur le cordon d'alimentation ou les câbles. Acheminez le cordon d'alimentation et les câbles de sorte que personne ne puisse marcher ou trébucher dessus.
 - ◆ Pour contribuer à protéger votre système contre les augmentations et diminutions soudaines et transitoires de puissance électrique, utilisez un parasurtenseur, un filtre de ligne ou un système d'alimentation sans coupure (UPS).
 - ◆ Placez les câbles du système et les câbles d'alimentation avec précaution; veillez à ce que rien ne repose sur aucun des câbles.
 - ◆ Lors du branchement ou du débranchement à des blocs d'alimentation permettant la connexion à chaud, veuillez respecter les lignes directrices suivantes:
 - ◆ Installez le bloc d'alimentation avant de brancher le câble d'alimentation à celui-ci.
 - ◆ Débranchez le câble d'alimentation avant de retirer le bloc d'alimentation.
 - ◆ Si le système présente plusieurs sources d'alimentation, déconnectez le système de l'alimentation en débranchant tous les câbles d'alimentation des blocs d'alimentation.
 - ◆ N'insérez jamais d'objets de quelque sorte que ce soit dans ou à travers les fentes du boîtier. Ils pourraient entrer en contact avec des points de tension dangereuse ou court-circuiter des pièces, entraînant ainsi un risque d'incendie ou de choc électrique.
 - ◆ N'essayez pas de réparer l'unité vous-même. Confiez toute opération de réparation à du personnel qualifié.
 - ◆ Si les conditions suivantes se produisent, débranchez l'unité de la prise murale et amenez-la à un technicien qualifié pour la faire réparer.
 - ◆ Le cordon d'alimentation ou la fiche ont été endommagés ou éraillés.
 - ◆ Du liquide a été renversé dans l'unité.
 - ◆ L'unité a été exposée à la pluie ou à l'eau.
 - ◆ L'unité est tombée ou le boîtier a été endommagé.
 - ◆ Les performances de l'unité sont visiblement altérées, ce qui indique la nécessité d'une réparation.
 - ◆ L'unité ne fonctionne pas normalement bien que les instructions d'utilisation soient respectées.
-

- ♦ N'utilisez que les commandes qui sont abordées dans le mode d'emploi. Le réglage incorrect d'autres commandes peut être à l'origine de dommages qui nécessiteront beaucoup de travail pour qu'un technicien qualifié puisse réparer l'unité.
- ♦ Ne connectez pas le connecteur RJ-11 portant la marque « Sensor » (Capteur) à un réseau de télécommunication public.

Rack Mounting

- ◆ Before working on the rack, make sure that the stabilizers are secured to the rack, extended to the floor, and that the full weight of the rack rests on the floor. Install front and side stabilizers on a single rack or front stabilizers for joined multiple racks before working on the rack.
- ◆ Always load the rack from the bottom up, and load the heaviest item in the rack first.
- ◆ Make sure that the rack is level and stable before extending a device from the rack.
- ◆ Use caution when pressing the device rail release latches and sliding a device into or out of a rack; the slide rails can pinch your fingers.
- ◆ After a device is inserted into the rack, carefully extend the rail into a locking position, and then slide the device into the rack.
- ◆ Do not overload the AC supply branch circuit that provides power to the rack. The total rack load should not exceed 80 percent of the branch circuit rating.
- ◆ Make sure that all equipment used on the rack – including power strips and other electrical connectors – is properly grounded.
- ◆ Ensure that proper airflow is provided to devices in the rack.
- ◆ Ensure that the operating ambient temperature of the rack environment does not exceed the maximum ambient temperature specified for the equipment by the manufacturer
- ◆ Do not step on or stand on any device when servicing other devices in a rack.

The eco PDU's Main Power Cord

Use the power cord supplied with this package. If it becomes necessary to replace the cord supplied with this package, be sure to use a cord of at least the same standard as the one provided.

Securing the Power Cables



To secure the cables in the eco PDU's power outlets, use only the ATEN Lok-U-Plug cable holders that have been specifically designed to work with the eco PDU. Using any other kind of cable securing device could be highly dangerous. Please contact your ATEN dealer for information about ATEN Lok-U-Plugs.

Montage sur bâti

- ♦ Avant de travailler sur le bâti, assurez-vous que les stabilisateurs sont bien fixés sur le bâti, qu'ils sont étendus au sol et que tout le poids du bâti repose sur le sol. Installez les stabilisateurs avant et latéraux sur un même bâti ou bien les stabilisateurs avant si plusieurs bâtis sont réunis, avant de travailler sur le bâti.
- ♦ Chargez toujours le bâti de bas en haut et chargez l'élément le plus lourd en premier.
- ♦ Assurez-vous que le bâti est à niveau et qu'il est stable avant de sortir une unité du bâti.
- ♦ Agissez avec précaution lorsque vous appuyez sur les loquets de libération du rail d'unité et lorsque vous faites coulisser une unité dans et hors d'un bâti ; vous pourriez vous pincer les doigts dans les rails.
- ♦ Une fois qu'une unité a été insérée dans le bâti, étendez avec précaution le rail dans une position de verrouillage puis faites glisser l'unité dans le bâti.
- ♦ Ne surchargez pas le circuit de l'alimentation CA qui alimente le bâti. La charge totale du bâti ne doit pas dépasser 80 % de la capacité du circuit.
- ♦ Assurez-vous que tous les équipements utilisés sur le bâti, y-compris les multiprises et autres connecteurs électriques, sont correctement mis à la terre.
- ♦ Assurez-vous que les unités présentes dans le bâti bénéficie d'une circulation d'air suffisante.
- ♦ Assurez-vous que la température ambiante de fonctionnement de l'environnement du bâti ne dépasse pas la température ambiante maximale spécifiée pour l'équipement par le fabricant.
- ♦ Ne marchez sur aucun appareil lors de la maintenance d'autres appareils d'un bâti.

Le cordon d'alimentation principale de l'unité d'alimentation éco

Utilisez le câble d'alimentation fourni. Au cas où il s'avèrerait nécessaire de remplacer le cordon fourni avec l'appareil, veillez à utiliser un cordon respectant au minimum la même norme que celui d'origine.



Fixation des câbles d'alimentation

Pour fixer les câbles aux sorties d'alimentation de l'unité d'alimentation éco, utilisez uniquement les supports de câble Lok-U-Plug d'ATEN qui ont été conçus spécialement pour être utilisés avec l'unité

d'alimentation éco. L'utilisation de tout autre type système de fixation de câble pourrait s'avérer très dangereuse. Veuillez contacter votre revendeur ATEN pour plus d'informations sur le support de câble ATEN Lok-U-Plug.

Technical Support

International

- ◆ For online technical support – including troubleshooting, documentation, and software updates: <http://eservice.aten.com>
- ◆ For telephone support, see *Telephone Support*, page v

North America

Email Support		support@aten-usa.com
Online Technical Support	Troubleshooting Documentation Software Updates	http://www.aten-usa.com/support
Telephone Support		1-888-999-ATEN ext 4988 1-949-428-1111

When you contact us, please have the following information ready beforehand:

- ◆ Product model number, serial number, and date of purchase.
- ◆ Your computer configuration, including operating system, revision level, expansion cards, and software.
- ◆ Any error messages displayed at the time the error occurred.
- ◆ The sequence of operations that led up to the error.
- ◆ Any other information you feel may be of help.

IP Address Determination

If you are an administrator logging in for the first time, you need to access the eco PDU in order to give it an IP address that users can connect to. There are two methods to choose from. In each case, your client computer must be on the same network segment as the eco PDU. After you have connected and logged in you can give the device its fixed network address.

Method 1:

For computers running Windows, an IP address can be determined and/or assigned with the IP Installer utility. The utility can be obtained from the *Download* area of our website. Look under *Driver/SW*, and the model of your device. After downloading the utility to your computer, do the following:

1. Unzip the contents of *IPInstaller.zip* to a directory on your hard drive.
2. Go to the directory that you unzipped the IPInstaller program to and run *IPInstaller.exe*. A dialog box similar to the one below appears:

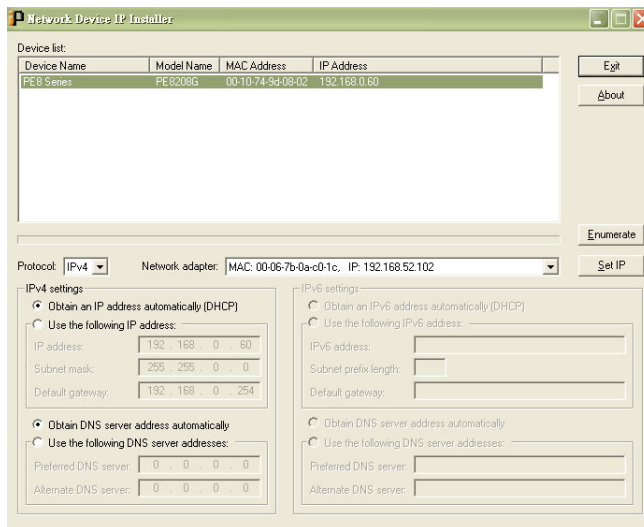

(Continues on next page.)

(Continued from previous page.)

3. Select the device in the *Device List*.

Note: 1. If the list is empty, or your device doesn't appear, click **Enumerate** to refresh the Device List.

2. If there is more than one device in the list, use the MAC address to pick the one you want. The eco PDU's MAC address is located on its bottom panel.
-

4. Select either *Obtain an IP address automatically (DHCP)*, or *Specify an IP address*. If you chose the latter, fill the IP Address, Subnet Mask, and Gateway fields with the information appropriate to your network.
5. Click **Set IP**.
6. After the IP address shows up in the Device List, click **Exit** to end the program.

Method 2:

1. Set your computer's IP address to 192.168.0.XXX
Where XXX represents any number or numbers except 60. (192.168.0.60) is the default address of the eco PDU.)
2. Specify the device's default IP address (192.168.0.60) in your browser, and you will be able to connect.
3. Assign a fixed IP address for the device that is suitable for the network segment that it resides on.
4. After you log out, reset your computer's IP address to its original value.
5. Once you have logged in, go to Network Settings to set up the permanent IP environment.

Method 3:

ATEN eco DC allows you to determine/assign an IP address in order to configure a PDU device and monitor power status of the equipment connected to it. ATEN eco DC can be obtained from the Download area of the ATEN website.

Specifications

PE5108A / PE5108B / PE5108G

	PE5108A	PE5108B	PE5108G
Electrical			
Nominal Input Voltage	100–120 VAC	100–240 VAC	100–240 VAC
Maximum Input Current	15A Max; 12A (UL de-rated)	15A Max; 12A (UL de-rated)	10A Max
Input Frequency	50–60 Hz	50–60 Hz	50–60 Hz
Input Connection	NEMA 5-15P	NEMA 6-15P	IEC 60320 C14
Input Power	1800 VA(Max); 1440 VA(UL de-rated)	3120 VA(Max); 2496 VA(UL de-rated)	2300 VA(Max)
Outlet Type	Total: 8 × NEMA 5-15R	Total: 8 × IEC320 C13	Total: 8 × IEC320 C13
Nominal Output Voltage	100–120 VAC	100–240 VAC	100–240 VAC
Maximum Output Current (Outlet)	◆ NEMA 5-15R: 15A (Max); 12A (UL de-rated)	◆ C13: 15A (Max); 12A (UL de-rated)	◆ C13: 10A (Max)
Maximum Output Current (Bank)	15A (Max); 12A (UL de-rated)	15A (Max); 12A (UL de-rated)	10A (Max)
Maximum Output Current (Total)	15A (Max); 12A(UL de-rated)	15A (Max); 12A(UL de-rated)	10A (Max)
Breakers	1 × 15A Non-Fuse Breaker	1 × 15A Non-Fuse Breaker	1 × 15A Non-Fuse Breaker
Metering	Bank level Current, Volt- age, VA , PF and KWh Monitoring	Bank level Current, Volt- age, VA , PF and KWh Monitoring	Bank level Current, Volt- age, VA , PF and KWh Monitoring
Outlet Switching	None	None	None

	PE5108A	PE5108B	PE5108G
Environment Sensor Ports	2	2	2
Metering Accuracy	<ul style="list-style-type: none"> ◆ Voltage Range: 100VAC–250VAC +/- 1% ◆ Power Range: 100W–Maximum Capacity +/- 2% ◆ Current Range: 0.1A–1A +/- 0.1A, 1A–20A +/-1% 	<ul style="list-style-type: none"> ◆ Voltage Range: 100VAC– 250VAC +/- 1% ◆ Power Range: 100W–Maximum Capacity +/- 2% ◆ Current Range: 0.1A–1A +/- 0.1A, 1A–20A +/-1% 	<ul style="list-style-type: none"> ◆ Voltage Range: 100VAC–250VAC +/- 1% ◆ Power Range: 100W –Maximum Capacity +/- 2% ◆ Current Range: 0.1A–1A +/- 0.1A, 1A–20A +/-1%
Physical Properties			
Dimensions (L x W x H)	43.24 × 4.40 x 21.93 cm	43.24 × 4.40 × 21.93 cm	43.24 × 4.40 × 21.93 cm
Weight	2.77 kg	2.82 kg	2.82 kg
Power Cord Length	3 m	3 m	3 m
Environmental			
Temperature (Operating / Storage)	0–50°C / -20–60°C	0–50°C / -20–60°C	0–50°C / -20–60°C
Humidity (Operating & Storage)	0–80% RH, Non-Condensing	0–80% RH, Non-Condensing	0–80% RH, Non-Condensing
Compliance			
EMC Verification	FCC, Others by Request	FCC, Others by Request	CE, Others by Request
Safety Verification	TUV-CB, cTUVus, UL, Others by Request	TUV-CB, cTUVus, UL, Others by Request	TUV-CB, CE-LVD, Others by Request

PE5208A / PE5208B / PE5208G

	PE5208A	PE5208B	PE5208G
Electrical			
Nominal Input Voltage	100–120 VAC	100–240 VAC	100–240 VAC
Maximum Input Current	20A Max; 16A(UL de-rated)	20A Max; 16A(UL de-rated)	16A Max
Input Frequency	50–60 Hz	50–60 Hz	50–60 Hz
Input Connection	NEMA 5-20P	<ul style="list-style-type: none"> ◆ PE5208B-ATA-J: NEMA L6-20P ◆ PE5208B-ATA-G: IEC 60320 C20 	IEC 60320 C20
Input Power	2400 VA (Max); 1920 VA(UL de-rated)	4160 VA (Max); 3328 VA(UL de-rated)	3680 VA (Max)
Outlet Type	Total: 8 × NEMA 5-20R	Total: 7 × IEC320 C13; 1 × IEC320 C19	Total: 7 × IEC320 C13; 1 × IEC320 C19
Nominal Output Voltage	100–120 VAC	100–240 VAC	100–240 VAC
Maximum Output Current (Outlet)	◆ NEMA 5-20R: 20A(Max); 16A(UL de-rated)	<ul style="list-style-type: none"> ◆ C13: 15A(Max); 12A(UL de-rated) ◆ C19: 20A(Max); 16A(UL de-rated) 	<ul style="list-style-type: none"> ◆ C13: 10A(Max) ◆ C19: 16A(Max)
Maximum Output Current (Bank)	20A (Max); 16A (UL de-rated)	20A (Max); 16A (UL de-rated)	16A (Max)
Maximum Output Current (Total)	20A (Max); 16A (UL de-rated)	20A (Max); 16A (UL de-rated)	16A (Max)
Breakers	1 × 20A Non-Fuse Breaker	1 × 20A Non-Fuse Breaker	1 × 16A Non-Fuse Breaker
Metering	Bank level Current, Voltage, VA , PF and KWh Monitoring	Bank level Current, Voltage, VA , PF and KWh Monitoring	Bank level Current, Voltage, VA , PF and KWh Monitoring
Outlet Switching	None	None	None

	PE5208A	PE5208B	PE5208G
Environment Sensor Ports	2	2	2
Metering Accuracy	<ul style="list-style-type: none"> ◆ Voltage Range: 100VAC–250VAC +/- 1% ◆ Power Range: 100W–Maximum Capacity +/- 2% ◆ Current Range: 0.1A–1A +/- 0.1A, 1A–20A +/-1% 	<ul style="list-style-type: none"> ◆ Voltage Range: 100VAC–250VAC +/- 1% ◆ Power Range: 100W–Maximum Capacity +/- 2% ◆ Current Range: 0.1A–1A +/- 0.1A, 1A–20A +/-1% 	<ul style="list-style-type: none"> ◆ Voltage Range: 100VAC–250VAC +/- 1% ◆ Power Range: 100W–Maximum Capacity +/- 2% ◆ Current Range: 0.1A–1A +/- 0.1A, 1A–20A +/-1%
Physical Properties			
Dimensions (L x W x H)	43.24 × 22.04 × 4.40 cm (17.02 × 8.68 × 1.73 in.)	43.24 × 22.04 × 4.40 cm (17.02 × 8.68 × 1.73 in.)	43.24 × 22.04 × 4.40 cm (17.02 × 8.68 × 1.73 in.)
Weight	2.71 kg (5.97 lb)	2.71 kg (5.97 lb)	2.71 kg (5.97 lb)
Power Cord Length	3 m	3 m	3 m
Environmental			
Temperature (Operating / Storage)	0–50°C / -20–60°C	0–50°C / -20–60°C	0–50°C / -20–60°C
Humidity (Operating & Storage)	0–80% RH, Non-Condensing	0–80% RH, Non-Condensing	0–80% RH, Non-Condensing
Compliance			
EMC Verification	FCC, Others by Request	FCC, Others by Request	CE, Others by Request
Safety Verification	TUV-CB, cTUVus, UL, Others by Request	TUV-CB, cTUVus, UL, Others by Request	TUV-CB, CE-LVD, Others by Request

PE6108A / PE6108B / PE6108G

	PE6108A	PE6108B	PE6108G
Electrical			
Nominal Input Voltage	100–120 VAC	100–240 VAC	100–240 VAC
Maximum Input Current	15A Max; 12A (UL de-rated)	15A Max; 12A (UL de-rated)	10A Max
Input Frequency	50–60 Hz	50–60 Hz	50–60 Hz
Input Connection	NEMA 5-15P	NEMA 5-15P	IEC 60320 C20
Input Power	1800 VA (Max); 1440 VA (UL de-rated)	3120 VA (Max); 2496 VA(UL de-rated)	2300 VA (Max)
Outlet Type	Total: 8 × NEMA 5-15R	Total: 8 × IEC320 C13	Total: 8 × IEC320 C13
Nominal Output Voltage	100–120 VAC	100–240 VAC	100–240 VAC
Maximum Output Current (Outlet)	NEMA 5-15R: 15A(Max); 12A(UL de-rated)	C13: 15A(Max); 12A(UL de-rated)	C13: 10A(Max)
Maximum Output Current (Bank)	15A (Max); 12A (UL de-rated)	15A (Max); 12A (UL de-rated)	10A (Max)
Maximum Output Current (Total)	15A (Max); 12A (UL de-rated)	15A (Max); 12A (UL de-rated)	10A (Max)
Breakers	1 × 15A Non-Fuse Breaker	1 × 15A Non-Fuse Breaker	1 × 15A Non-Fuse Breaker
Metering	Bank level Current, Voltage, VA , PF and KWh Monitoring	Bank level Current, Voltage, VA , PF and KWh Monitoring	Bank level Current, Voltage, VA , PF and KWh Monitoring
Outlet Switching	Yes	Yes	Yes
Environment Sensor Ports	2	2	2

	PE6108A	PE6108B	PE6108G
Metering Accuracy	<ul style="list-style-type: none"> ◆ Voltage Range: 100VAC–250VAC +/- 1% ◆ Power Range: 100W –Maximum Capacity +/- 2% ◆ Current Range: 0.1A–1A +/- 0.1A, 1A–20A +/--1% 	<ul style="list-style-type: none"> ◆ Voltage Range: 100VAC–250VAC +/- 1% ◆ Power Range: 100W –Maximum Capacity +/- 2% ◆ Current Range: 0.1A–1A +/- 0.1A, 1A–20A +/--1% 	<ul style="list-style-type: none"> ◆ Voltage Range: 100VAC–250VAC +/- 1% ◆ Power Range: 100W –Maximum Capacity +/- 2% ◆ Current Range: 0.1A–1A +/- 0.1A, 1A–20A +/--1%
Physical Properties			
Dimensions (L x W x H)	43.24 × 22.04 × 4.40 cm (17.02 × 8.68 × 1.73 in.)	43.24 × 22.04 × 4.40 cm (17.02 × 8.68 × 1.73 in.)	43.24 × 22.04 × 4.40 cm (17.02 × 8.68 × 1.73 in.)
Weight	2.77 kg (6.1 lb)	2.77 kg (6.1 lb)	2.77 kg (6.1 lb)
Power Cord Length	3 m	3 m	3 m
Environmental			
Temperature (Operating / Storage)	0–50°C / -20–60°C	0–50°C / -20–60°C	0–50°C / -20–60°C
Humidity (Operating & Storage)	0–80% RH, Non-Condensing	0–80% RH, Non-Condensing	0–80% RH, Non-Condensing
Compliance			
EMC Verification	FCC, Others by Request	FCC, Others by Request	CE, Others by Request
Safety Verification	TUV-CB, cTUVus, UL, Others by Request	TUV-CB, cTUVus, UL, Others by Request	TUV-CB, CE-LVD, Others by Request

PE6208A / PE6208B / PE6208G

	PE6208A	PE6208B	PE6208G
Electrical			
Nominal Input Voltage	100–120 VAC	100–240 VAC	100–240 VAC
Maximum Input Current	20A Max; 16A(UL de-rated)	20A Max; 16A(UL de-rated)	16A Max
Input Frequency	50–60 Hz	50–60 Hz	50–60 Hz
Input Connection	◆ PE6208A-ATA-A: NEMA 5 -20P ◆ PE6208A-ATA-J: NEMA L5-20P	◆ PE6208B-ATA-B: NEMA 6 -20P ◆ PE6208B-ATA-J: NEMA L6 -20P	IEC 60320 C14
Input Power	2400 VA (Max); 1920 VA(UL de-rated)	4160 VA (Max); 3328 VA(UL de-rated)	3680 VA (Max)
Outlet Type	Total: 8 × NEMA 5-20R	Total: 7 × IEC320 C13; 1 × IEC320 C19	Total: 7 × IEC320 C13; 1 × IEC320 C19
Nominal Output Voltage	100–120 VAC	100–240 VAC	100–240 VAC
Maximum Output Current (Outlet)	◆ NEMA 5-20R: 20A(Max); 16A(UL de-rated)	◆ C13: 15A(Max); 12A(UL de-rated) ◆ C19: 20A(Max); 16A(UL de-rated)	◆ C13: 10A(Max) ◆ C19: 16A(Max)
Maximum Output Current (Bank)	20A (Max); 16A (UL de-rated)	20A (Max); 16A (UL de-rated)	16A (Max)
Maximum Output Current (Total)	20A (Max); 16A (UL de-rated)	20A (Max); 16A (UL de-rated)	16A (Max)
Breakers	1 × 20A Non-Fuse Breaker	1 × 20A Non-Fuse Breaker	1 × 16A Non-Fuse Breaker
Metering	Bank level Current, Voltage, VA , PF and KWh Monitoring	Bank level Current, Voltage, VA , PF and KWh Monitoring	Bank level Current, Voltage, VA , PF and KWh Monitoring
Outlet Switching	Yes	Yes	Yes

	PE6208A	PE6208B	PE6208G
Environment Sensor Ports	2	2	2
Metering Accuracy	<ul style="list-style-type: none"> ◆ Voltage Range: 100VAC–250VAC +/- 1% ◆ Power Range: 100W–Maximum Capacity +/- 2% ◆ Current Range: 0.1A–1A +/- 0.1A, 1A–20A +/-1% 	<ul style="list-style-type: none"> ◆ Voltage Range: 100VAC–250VAC +/- 1% ◆ Power Range: 100W–Maximum Capacity +/- 2% ◆ Current Range: 0.1A–1A +/- 0.1A, 1A–20A +/-1% 	<ul style="list-style-type: none"> ◆ Voltage Range: 100VAC–250VAC +/- 1% ◆ Power Range: 100W–Maximum Capacity +/- 2% ◆ Current Range: 0.1A–1A +/- 0.1A, 1A–20A +/-1%
Physical Properties			
Dimensions (L x W x H)	43.24 × 22.04 × 4.40 cm (17.02 × 8.68 × 1.73 in.)	43.24 × 22.04 × 4.40 cm (17.02 × 8.68 × 1.73 in.)	43.24 × 22.04 × 4.40 cm (17.02 × 8.68 × 1.73 in.)
Weight	2.79 kg (6.15 lb)	2.79 kg (6.15 lb)	2.79 kg (6.15 lb)
Power Cord Length	3 m	3 m	3 m
Environmental			
Temperature (Operating / Storage)	0–50°C / -20–60°C	0–50°C / -20–60°C	0–50°C / -20–60°C
Humidity (Operating & Storage)	0–80% RH, Non-Condensing	0–80% RH, Non-Condensing	0–80% RH, Non-Condensing
Compliance			
EMC Verification	FCC, Others by Request	FCC, Others by Request	CE, Others by Request
Safety Verification	TUV-CB, cTUVus, UL, Others by Request	TUV-CB, cTUVus, UL, Others by Request	TUV-CB, CE-LVD, Others by Request

PE8108A / PE8108B / PE8108G

	PE8108A	PE8108B	PE8108G
Electrical			
Nominal Input Voltage	100–120 VAC	100–240 VAC	100–240 VAC
Maximum Input Current	15A Max; 12A (UL de-rated)	15A Max; 12A (UL de-rated)	10A Max
Input Frequency	50–60 Hz	50–60 Hz	50–60 Hz
Input Connection	NEMA 5-15P	NEMA 6-15P	IEC 60320 C14
Input Power	1800 VA (Max); 1440 VA (UL de-rated)	3120 VA (Max); 2496 VA(UL de-rated)	2300 VA (Max)
Outlet Type	Total: 8 × NEMA 5-15R	Total: 8 × IEC320 C13	Total: 8 × IEC320 C13
Nominal Output Voltage	100–120 VAC	100–240 VAC	100–240 VAC
Maximum Output Current (Outlet)	NEMA 5-15R: 15A(Max); 12A(UL de-rated)	C13: 15A(Max); 12A(UL de-rated)	C13: 10A(Max)
Maximum Output Current (Bank)	15A (Max); 12A (UL de-rated)	15A (Max); 12A (UL de-rated)	10A (Max)
Maximum Output Current (Total)	15A (Max); 12A (UL de-rated)	15A (Max); 12A (UL de-rated)	10A (Max)
Breakers	1 × 15A Non-Fuse Breaker	1 × 15A Non-Fuse Breaker	1 × 15A Non-Fuse Breaker
Metering	Outlet level Current, Voltage, VA , PF and KWh Monitoring	Outlet level Current, Voltage, VA , PF and KWh Monitoring	Outlet level Current, Voltage, VA , PF and KWh Monitoring
Outlet Switching	Yes	Yes	Yes
Environment Sensor Ports	2	2	2

	PE8108A	PE8108B	PE8108G
Metering Accuracy	<ul style="list-style-type: none"> ◆ Voltage Range: 100VAC–250VAC +/- 1% ◆ Power Range: 100W –Maximum Capacity +/- 2% ◆ Current Range: 0.1A–1A +/- 0.1A, 1A–20A +/-1% 	<ul style="list-style-type: none"> ◆ Voltage Range: 100VAC–250VAC +/- 1% ◆ Power Range: 100W –Maximum Capacity +/- 2% ◆ Current Range: 0.1A–1A +/- 0.1A, 1A–20A +/-1% 	<ul style="list-style-type: none"> ◆ Voltage Range: 100VAC–250VAC +/- 1% ◆ Power Range: 100W –Maximum Capacity +/- 2% ◆ Current Range: 0.1A–1A +/- 0.1A, 1A–20A +/-1%
Physical Properties			
Dimensions (L x W x H)	43.24 × 22.04 × 4.40 cm (17.02 × 8.68 × 1.73 in.)	43.24 × 22.04 × 4.40 cm (17.02 × 8.68 × 1.73 in.)	43.24 × 22.04 × 4.40 cm (17.02 × 8.68 × 1.73 in.)
Weight	2.75 kg (6.06 lb)	2.75 kg (6.06 lb)	2.75 kg (6.06 lb)
Power Cord Length	3 m	3 m	3 m
Environmental			
Temperature (Operating / Storage)	0–50°C / -20–60°C	0–50°C / -20–60°C	0–50°C / -20–60°C
Humidity (Operating & Storage)	0–80% RH, Non-Condensing	0–80% RH, Non-Condensing	0–80% RH, Non-Condensing
Compliance			
EMC Verification	FCC, Others by Request	FCC, Others by Request	CE, Others by Request
Safety Verification	TUV-CB, cTUVus, UL, Others by Request	TUV-CB, cTUVus, UL, Others by Request	TUV-CB, CE-LVD, GOST, Others by Request

PE8208A / PE8208B / PE8208G

	PE8208A	PE8208B	PE8208G
Electrical			
Nominal Input Voltage	100–120 VAC	100–240 VAC	100–240 VAC
Maximum Input Current	20A Max; 16A(UL de-rated)	20A Max; 16A(UL de-rated)	16A Max
Input Frequency	50–60 Hz	50–60 Hz	50–60 Hz
Input Connection	NEMA 5-20P	NEMA 6-20P	IEC 60320 C20
Input Power	2400 VA (Max); 1920 VA(UL de-rated)	4160 VA (Max); 3328 VA(UL de-rated)	3680 VA (Max)
Outlet Type	Total: 8 × NEMA 5-20R	Total: 7 × IEC320 C13; 1 × IEC320 C19	Total: 7 × IEC320 C13; 1 × IEC320 C19
Nominal Output Voltage	100–120 VAC	100–240 VAC	100–240 VAC
Maximum Output Current (Outlet)	◆ NEMA 5-20R: 20A(Max); 16A(UL de-rated)	◆ C13: 15A(Max); 12A(UL de-rated) ◆ C19: 20A(Max); 16A(UL de-rated)	◆ C13: 10A(Max) ◆ C19: 16A(Max)
Maximum Output Current (Bank)	20A (Max); 16A (UL de-rated)	20A (Max); 16A (UL de-rated)	16A (Max)
Maximum Output Current (Total)	20A (Max); 16A (UL de-rated)	20A (Max); 16A (UL de-rated)	16A (Max)
Breakers	1 × 20A Non-Fuse Breaker	1 × 20A Non-Fuse Breaker	1 × 16A Non-Fuse Breaker
Metering	Outlet level Current, Voltage, VA , PF and KWh Monitoring	Outlet level Current, Voltage, VA , PF and KWh Monitoring	Outlet level Current, Voltage, VA , PF and KWh Monitoring
Outlet Switching	Yes	Yes	Yes

	PE8208A	PE8208B	PE8208G
Environment Sensor Ports	2	2	2
Metering Accuracy	<ul style="list-style-type: none"> ◆ Voltage Range: 100VAC–250VAC +/- 1% ◆ Power Range: 100W–Maximum Capacity +/- 2% ◆ Current Range: 0.1A–1A +/- 0.1A, 1A–20A +/-1% 	<ul style="list-style-type: none"> ◆ Voltage Range: 100VAC–250VAC +/- 1% ◆ Power Range: 100W–Maximum Capacity +/- 2% ◆ Current Range: 0.1A–1A +/- 0.1A, 1A–20A +/-1% 	<ul style="list-style-type: none"> ◆ Voltage Range: 100VAC–250VAC +/- 1% ◆ Power Range: 100W–Maximum Capacity +/- 2% ◆ Current Range: 0.1A–1A +/- 0.1A, 1A–20A +/-1%
Physical Properties			
Dimensions (L x W x H)	43.24 × 22.04 × 4.40 cm (17.02 × 8.68 × 1.73 in.)	43.24 × 22.04 × 4.40 cm (17.02 × 8.68 × 1.73 in.)	43.24 × 22.04 × 4.40 cm (17.02 × 8.68 × 1.73 in.)
Weight	2.84 kg (6.26 lb)	2.84 kg (6.26 lb)	2.84 kg (6.26 lb)
Power Cord Length	3 m	3 m	3 m
Environmental			
Temperature (Operating / Storage)	0–50°C / -20–60°C	0–50°C / -20–60°C	0–50°C / -20–60°C
Humidity (Operating & Storage)	0–80% RH, Non-Condensing	0–80% RH, Non-Condensing	0–80% RH, Non-Condensing
Compliance			
EMC Verification	FCC, Others by Request	FCC, Others by Request	CE, Others by Request
Safety Verification	TUV-CB, cTUVus, UL, Others by Request	TUV-CB, cTUVus, UL, Others by Request	TUV-CB, CE-LVD, GOST, Others by Request

Administrator Login Failure

If you are unable to perform an administrator login (because the username and password information has become corrupted, or you have forgotten it, for example), you can clear the login information with the following procedure:

1. Power off the eco PDU and remove its housing.
2. Short the jumper labeled J6 (PIN10 and PIN9).

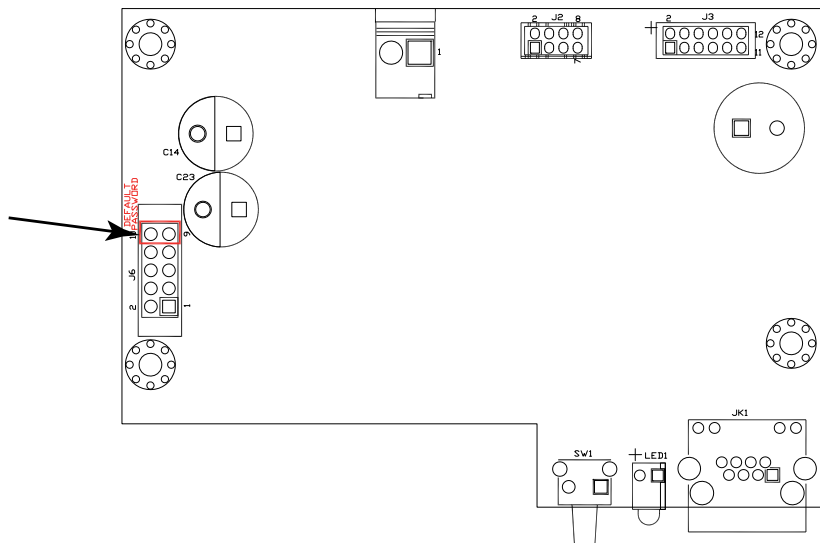

3. Power on the eco PDU.
4. When the 1-digit, 7-segment display shows "P", power off the PDU.
5. Remove the jumper cap from J6.
6. Close the housing and start the eco PDU.
After you start, you can use the default username and password to log in.

ATEN Warranty Policy

The warranty policy may vary by product category and region of purchase. For details, please visit ATEN's official website, select your purchase counties/regions and then go to the Support Center, or contact your local ATEN sales representative for further assistance.

Copyright © 2025 ATEN® International Co., Ltd.
Released: 2025-03-07

ATEN and the ATEN logo are registered trademarks of ATEN International Co., Ltd. All rights reserved. All other brand names and trademarks are the registered property of their respective owners.