



Simply Better Connections

PG5308A / PG5308B

PG5308G / PG6308A

PG6308B / PG6308G

PG8208G / PG8308A

PG8308B / PG8308G

8-Outlet 1U eco PDU

User Manual

Compliance Statements

FEDERAL COMMUNICATIONS COMMISSION INTERFERENCE STATEMENT

This equipment has been tested and found to comply with the limits for a Class A digital device, pursuant to Part 15 of the FCC Rules. These limits are designed to provide reasonable protection against harmful interference when the equipment is operated in a commercial environment. This equipment generates, uses, and can radiate radio frequency energy and, if not installed and used in accordance with the instruction manual, may cause harmful interference to radio communications. Operation of this equipment in a residential area is likely to cause harmful interference in which case the user will be required to correct the interference at his own expense.

The device complies with Part 15 of the FCC Rules. Operation is subject to the following two conditions: (1) this device may not cause harmful interference, and (2) this device must accept any interference received, including interference that may cause undesired operation.

FCC Caution

Any changes or modifications not expressly approved by the party responsible for compliance could void the user's authority to operate this equipment.

Warning

Operation of this equipment in a residential environment could cause radio interference.

Achtung

Der Gebrauch dieses Geräts in Wohnumgebung kann Funkstörungen verursachen.



Note 1: Caution "High touch current"

Note 2: Connect to earth before connecting to supply

Industry Canada Statement

This Class A digital apparatus complies with Canadian ICES-003.

CAN ICES-003 (A) / NMB-003 (A)

RoHS

This product is RoHS compliant.

PE Device Safety Notice



- ◆ Set the maximum permissible breaker protection in the building circuitry to the current rating specified on the rating plate. Observe all national regulations and safety codes as well as deviations for breakers.
- ◆ Only connect the PE Device to a grounded power outlet or a grounded system!
- ◆ Make sure that the total current input of the connected systems does not exceed the current rating specified on the rating plate of the PE

User Information

Online Registration

Be sure to register your product at our online support center:

International	http://eservice.aten.com
---------------	---

Telephone Support

For telephone support, call this number:

International	886-2-8692-6959
China	86-400--810-0-810
Japan	81-3-5615-5811
Korea	82-2-467-6789
North America	1-888-999-ATEN ext 4988 1-949-428-1111

User Notice

All information, documentation, and specifications contained in this manual are subject to change without prior notification by the manufacturer. The manufacturer makes no representations or warranties, either expressed or implied, with respect to the contents hereof and specifically disclaims any warranties as to merchantability or fitness for any particular purpose. Any of the manufacturer's software described in this manual is sold or licensed *as is*. Should the programs prove defective following their purchase, the buyer (and not the manufacturer, its distributor, or its dealer), assumes the entire cost of all necessary servicing, repair and any incidental or consequential damages resulting from any defect in the software.

The manufacturer of this system is not responsible for any radio and/or TV interference caused by unauthorized modifications to this device. It is the responsibility of the user to correct such interference.

The manufacturer is not responsible for any damage incurred in the operation of this system if the correct operational voltage setting was not selected prior to operation. PLEASE VERIFY THAT THE VOLTAGE SETTING IS CORRECT BEFORE USE.

If any bodily injury or property damage with respect to operation of the product results from users not having installed the product in accordance with the instructions provided in the product's user manual, or the product is used in an environment with a current load over the designed specifications of the product, ATEN is not liable for any loss or damage.

Product Information

For information about all ATEN products and how they can help you connect without limits, visit ATEN on the Web or contact an ATEN Authorized Reseller. Visit ATEN on the Web for a list of locations and telephone numbers:

International	http://www.aten.com
North America	http://www.aten-usa.com

Package Contents

Check to make sure that all the components are in working order. If you encounter any problem, please contact your dealer.

The eco PDU PG series standard package consists of:

- 1 8-Outlet 1U eco PDU
- 1 rack mount kit
- 1 foot pad set (4 pcs)
- 1 RJ-45 to DB-9 cable
- 1 power cord (only applicable to PG8208G)
- 1 full-panel colored sticker
- 1 user instructions

Contents

Compliance Statements	ii
User Information	iv
Online Registration	iv
Telephone Support	iv
User Notice	iv
Product Information	v
Package Contents	v
Contents	vi
About This Manual	xii
Conventions	xiii
Usage of Terms	xiii

Chapter 1. Introduction

Overview	1
Features	3
Connections	3
Metering	3
Network	4
Outlet Switch Control	4
Proactive Overload Protection (POP)	5
Requirements	6
Cable Holders	6
Components	7
PG5308A Front View	7
PG6308A / PG8308A Front View	9
PG5308B / PG5308G Front View	11
PG6308B / PG6308G / PG8308B / PG8308G Front View	13
PG5308 / PG6308 / PG8308 Rear View	15
PG8208G Front View	16
PG8208G Rear View	18

Chapter 2. Hardware Setup

Before You Begin	19
Rack Mount	19
Installation	21
Securing the Cables	23

RS-232 Command List	24
Cascade & Bridge	25
Cascade	25
Bridge	25
Concatenate eco PDUs by Bridge and Cascade	26

Chapter 3. Basic Operation and First-Time Setup

Operation Methods	27
Browser	27
eco DC	27
SNMP	27
First-Time Setup	28
Network Configuration	29
Changing the Administrator Login	30
Moving On	31

Chapter 4. Logging In

Logging In	33
The eco PDU Main Page	34
Page Components	35

Chapter 5. Energy

Connection	37
PDU Status	38
Environment Sensor Status	38
Bank Status	39
Outlet Status	40
Configuration	41
POP Settings	41
Power On Time Schedule Settings	42
Bank Configuration	42
Bank POP Priority List	42
Outlet Configuration	43
Sensor Config	46
Sensor Installation	47

Chapter 6. User Management

Overview	49
Administrator Information	50
User Information	51

Chapter 7. Log

Overview	53
The System Log Event List	54
Notification Settings	55

Chapter 8. Setup

Device Management	57
Device Configuration	58
General	58
Service Ports	58
Serial Settings	59
IPv4 Configuration	59
IPv6 Configuration	61
Event Notification	62
SMTP Server	62
SNMP Trap Receivers	63
Syslog Server	64
Date/Time	64
Time Zone	65
Manual Input	65
Network Time	66
Finishing Up	66
Security	67
Login Failures	67
Working Mode	68
TLS Support	68
IP Installer Setting	68
Session Timeout	69
Account Policy	69
IP Filter / MAC Filter	70
Adding Filters	70
IP Filter / MAC Filter Conflict	71
Modifying Filters	71

Deleting Filters	71
Authentication & Authorization	72
RADIUS Settings	72
LDAP Settings	73
TACACS+ Settings	74
Private Certificate	75
Generating a Self-Signed Certificate	76
Obtaining a CA Signed SSL Server Certificate	76
Importing the Private Certificate	76
Wireless Network	77
IPv4 Configuration	78
IPv6 Configuration	79
Cascade	80
Adding a PDU	80
Deleting a PDU	80
Connecting a PDU	81
Discovering	81
Rules	82
Add a New Rule	82
Edit the Rules	83
Scheduler	84
Creating an Event	84
Python Script	87
Add a New Script	87
Script Management	88
ATEN Python Library	89
Get Outlet Info	89
Get inlet Info	89
Get Bank Info	90
Change Outlet Status	90
Get Sensor Info	90

Chapter 9.PDU

Overview	93
Upgrade Main Firmware	94
Upgrading the Firmware	95
Firmware Upgrade Recovery	95
Backup/Restore	96

Station List	96
Backup	96
Restore	97

Chapter 10.LCD Menu

Readout Section on eco PDU	99
Home Screen	100
Alert	101
Measure	102
Sensor	103
Dry Contact.	104
Switch ON/OFF	105
Device	105
Bank	106
Outlet.	107
Network	108
Cascade	109
Settings	110
Log	111
PDU	112

Chapter 11.Telnet Commands

Remote Terminal Operations	113
Telnet	113
Setup	113
Logging In	114
Session Timeout	115
Commands	116
Verification	116
Read Power Outlet Status	117
Switch Outlet Status	118
Read Environmental Value	120
Close Telnet Session	121
Reboot PDU Device	122

Appendix

Safety Instructions	123
General	123

Rack Mounting	125
The eco PDU's Main Power Cord	126
Securing the Power Cables	126
Resetting the Circuit Breaker	127
Recovery Procedure:.....	127
Technical Support	128
International	128
North America	128
IP Address Determination	129
Method 1	129
Method 2	130
Method 3	130
Specifications	131
PG5308A / PG5308B / PG5308G	131
PG6308A / PG6308B / PG6308G	133
PG8308A / PG8308B / PG8308G	135
PG8208G	137
ATEN Warranty Policy	138

About This Manual

This manual is provided to help you get the most out of your eco PDU. It covers all aspects of the power distribution unit, including installation, configuration, and operation. An overview of the information found in the manual is provided below.

Chapter 1, *Introduction*, introduces you to the unit/system. It presents purpose, features and benefits are presented, and its front and back panel components are described.

Chapter 2, *Hardware Setup*, provides step-by-step instructions for setting up your installation, and explains some basic operation procedures.

Chapter 3, *Basic Operation and First-Time Setup*, explains the procedures that the administrator employs to set up the eco PDU network environment, and change the default username and password.

Chapter 4, *Logging In*, describes how to log in to the eco PDU with an Internet browser, and explains the layout and components of the user interface.

Chapter 5, *Energy*, describes how to monitor and configure the eco PDU energy settings.

Chapter 6, *User Management*, describes how to configure the eco PDU user management such as username and password.

Chapter 7, *Log*, describes how to read and export log from the eco PDU.

Chapter 8, *Setup*, describes how to configure and manage the eco PDU as a whole.

Chapter 9, *PDU*, describes how to perform a firmware upgrade on the eco PDU, or back up and restore files.

Chapter 10, *LCD Menu*, describes the functions on the eco PDU's LCD screen.

Chapter 11, *Telnet Commands*, describes how to connect to and access the eco PDU's using Telnet.

Appendix, at the end of the manual provides technical and troubleshooting information.

Note:

- ◆ Read this manual thoroughly and follow the installation and operation procedures carefully to prevent any damage to the unit and/or connected devices.
 - ◆ The product may be updated, with features and functions added, improved, or removed since the release of this manual. For an up-to-date user manual, visit <http://www.aten.com/global/en/>.
-

Conventions

This manual uses the following conventions:

Monospaced	Indicates text that you should key in.
[]	Indicates keys you should press. For example, [Enter] means to press the Enter key. If keys need to be chorded, they appear together in the same bracket with a plus sign between them: [Ctrl+Alt].
1.	Numbered lists represent procedures with sequential steps.
◆	Bullet lists provide information, but do not involve sequential steps.
>	Indicates selecting consecutive options (such as on a menu or dialog box). For example, Start > Run means to open the <i>Start</i> menu, and then select <i>Run</i> .
	Indicates critical information.

Usage of Terms

A model number without the -A, -B, or -G ending is used to refer to all variants of the model. For example, PG8308 refers to PG8308A, PG8308B, and PG8308G altogether.

This Page Intentionally Left Blank

Chapter 1

Introduction

Overview

ATEN's PG series intelligent PDU lineup includes PG53 metered series, PG63 switched series, and PG83 / PG82 outlet-metered & switched series. Each PG series intelligent PDU features 8 outlets* housed in a compact 1U rack enclosure.

With an ARM Cortex-A8 processor, these PDUs provide advanced control options through USB, COM, environmental sensors, and dual Gigabit LAN ports. Designed for rapid deployment, PG series PDUs can power all connected equipment within just 10 seconds of being plugged in. For enhanced cost efficiency and space optimization, these intelligent PDUs can be cascaded, allowing interconnection of up to 64 units.

The PG series PDUs are equipped with RJ-45 sensor ports to connect with EA1640 that monitor the health of the data center environment, ensuring optimal operating conditions. They offer secure, centralized, and intelligent power management capabilities, allowing users to power on, off, or cycle data center IT equipment such as servers, storage systems, KVM switches, network devices, and serial data devices.

With the integration of remote power control and real-time power measurement, users can manage and monitor the power status of devices connected to the PG series PDUs from virtually anywhere with an IP connection. This functionality is accessible at the PDU device, bank, or outlet level, depending on the specific model.

These intelligent PDUs are capable of handling high voltage ranges of 100V to 240V. Additionally, they provide precise kWh energy usage data with an accuracy of $\pm 1\%$. This level of precision enhances the monitoring of power consumption, aids in the establishment of baseline energy usage, and supports the tracking of energy efficiency initiatives.

In terms of hardware design, the PG series PDUs incorporate built-in energy-saving relays—subtypes of electromagnetic switches—to manage large current flows more efficiently, resulting in lower energy consumption compared to non-relay models. The PG series models (except for the PG8208G) are equipped with circuit breakers that support 30A or 32A

currents, automatically disconnect the power supply to prevent overloads, and protect connected devices from damage.

The firmware of the PG series is upgradeable via web GUI or USB, allowing users to conveniently download updates from ATEN's website, ensuring access to the latest functionalities and improvements for practical use.

Green LCD console panel sticker is included for users, with additional options in blue, yellow, red, and purple available for purchase. This color-coding system enhances the ability to differentiate between power feed settings and facilitates more efficient troubleshooting.

The PG series intelligent PDUs are ideally suited for enterprise server rooms, network closets, and data centers, providing an intelligent power distribution and management solution that meets the demands of high-density IT applications while optimizing overall costs.

-
- Note:**
- ◆ PG5308A / PG6308A / PG8308A contains 8 × NEMA 5-20R socket configurations.
 - ◆ PG5308B / PG5308G / PG6308B / PG6308G / PG8308B / PG8308G contains 6 × IEC60320 C13 and 2 × IEC60320 C19 socket configurations.
 - ◆ PG8208G contains 7 × IEC60320 C13 and 1 × IEC60320 C19 socket configurations.
-

Features

Connections

- ◆ Supports 1Gbps Ethernet Interface
- ◆ Remote Management Protocols—TCP/IP, UDP, HTTP, HTTPS, SSL, DHCP, SMTP (TLS 1.2), ARP, NTP, DNS, Auto Sense, Ping, SNMP V1, V2, and V3, Telnet, Modbus (over TCP/IP), Wi-Fi, and IPv6
- ◆ Scripting—JSON-RPC (Remote Procedure Call) protocol and Python scripting to control specified PDU units
- ◆ Security—2-level account/password login access, and IP/MAC filter, 128 bit SSL
- ◆ Authentication—RADIUS, LDAP, TACACS
- ◆ Supports eco-DC and multiple browsers (IE, Firefox, Chrome, and Safari)
- ◆ Supports RS-232 and RS-485 communication ports.
- ◆ Auto Ping & Reboot
- ◆ Environment sensor port enables RJ-45 connectivity to connect or daisy-chain up to 8 environment sensors such as ATEN EA1640 for monitoring and management of temperature, humidity, airflow, differential air pressure, and leaks, featuring alerts for potential threats (sold separately)
- ◆ Rotatable LCD Screen—capable of 180-degree rotation, delivering flexible in-rack installation

Metering

- ◆ Secure locking enhancement prevents power cords from becoming unplugged due to vibration or human error
- ◆ Metering and monitoring of power at the PDU and outlet levels
- ◆ Measuring and establishing threshold levels for current, voltage, power, power dissipation, temperature, and humidity
- ◆ Precise kWh metering (+/-1%) for better power consumption habits, baselines, and initiative tracking
- ◆ Real-time LCD alert sends warnings to alert users of unusual power state

Network

- ◆ Dual Ethernet ports support cascading up to 64 PDUs
- ◆ Daisy chaining functions support SNMP & Modbus protocols and TC / IP protocols (web page)
- ◆ PON port can be connected to the KN series (up to 16 KN devices) and be secondary

Note: To be included in a future firmware release.

- ◆ Supports ATEN's eco DC (Energy & DCIM Management Web GUI) for monitoring power distribution, energy, and environmental data from PDUs and connected devices

Outlet Switch Control

- ◆ Remote power outlet control (On/Off, Power Cycle) by individual outlets and outlet groups
- ◆ Outlet group support at the PDU level
- ◆ Supports multiple power control methods—Wake on LAN, System After AC Back, Kill the Power
- ◆ Power-On/Off sequencing—users can set the power-on sequence and delay time for each outlet to allow equipment to be powered on in the correct order
- ◆ Proactive overload protection (POP)—automatically powers off the last outlet, causing the current overload, while allowing users to set shutdown priority
- ◆ Schedule Control
- ◆ When the temperature or humidity sensor value reaches the predetermined threshold, the PDU can turn on, off, or reboot a particular outlet
- ◆ Energy-efficient relays allow operators to control large amounts of current flow for lower energy consumption

Proactive Overload Protection (POP)

The PG6308 / PG8208 / PG8308 models feature ATEN's exclusive Proactive Overload Protection (POP) technology. Effective on all non-critical outlets, this added safety feature automatically powers off outlets when a current overload occurs.

Note: PG5308 doesn't support POP function.

Requirements

- ◆ Browsers accessing the eco PDU must support TLS 1.0.
- ◆ For cold booting of attached computers, the computer's BIOS must support *Wake on LAN* or *System after AC Back*.
- ◆ For Safe Shutdown:
 - ◆ The computer must be running Windows (2000 or above) or Linux.
 - ◆ The *Safe Shutdown* program—PMonitor—must be installed and running on the computer (available by download from our website).

Note:

Safe shutdown program PMonitor can be downloaded from the *Support and Download* section of the product web page, as shown below

Software & Drivers ▾

OS	Description	Ver.	Release Date	File Name
Other				
	MIB File	v1.1.115	2015-05-05	PE_MIB_File_v1.1.115.zip
	PE MIB File	v1.1.112	2014-06-19	PE8_MIB_File_v1.1.112.tar
	PE MIB File	v1.1.109	2013-09-06	PE8_MIB_File_v1.1.109.tar
	IP Installer	v1.4.132	2012-02-10	IPInstaller-ALTUSEN_v1.4.132.zip
Linux	PMonitor	v1.1	2012-02-10	PowerMonitor_v1.1.zip
Windows	PMonitor	v1.0.081	2012-02-10	PMonitorSrv_v1.0.081.zip
	PE MIB File	v1.0.063	2012-02-10	PE8_MIB_File_v1.0.063.zip

Cable Holders

Cable holders are optional accessories. For added safety, use ATEN Lok-U-Plug cable holders to secure the cables from your attached devices in place on the eco PDU. Only the ATEN Lok-U-Plug cable holders that have been specifically designed to work with the eco PDU can be used. Using any other kinds of cable securing device could potentially result in irreversible damage or harm to the device or users. For a list of compatible cable holders, please refer to the Compatible Products section on the product web page.

Components

PG5308A Front View

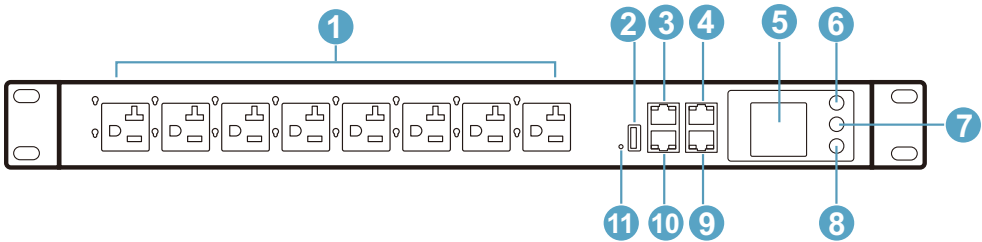

No.	Item	Description
1	power outlets	8 × NEMA 5-20R Note: Holes for ATEN Lok-U-Plug cable holders are located around the outlets. See <i>Securing the Cables</i> , page 23, for further information.
2	USB Type-A port	Connects to a USB Type-A storage device for firmware upgrade or log export. <ul style="list-style-type: none"> USB firmware upgrade: The eco PDUs support quickly firmware upgrade through USB port. USB setting & log file restored: Users can export the setting and the log file through USB.
3	COM + PON port	<ul style="list-style-type: none"> COM: Connects to a hardware or software controller for remote control. PON: Connects to KN series for cascading up to 16 PG PDUs.
4	LAN 1	The cable that connects the unit to the Internet, LAN, WAN, or to cascade up to 64 PG PDUs plugs in here.
5	LCD panel	When PDU / Bank / Outlet is selected, readouts for its current, voltage, power, and IP address appear in the display window.

No.	Item	Description
6	menu / back button	Press the button to return to the previous page on the LCD display. Press and hold the button for 2 seconds to go back to the main menu.
7	select button	Press the button to cycle the selection between the items; the LCD display indicates which one is currently displayed.
8	enter button	Press the button to enter the page of the selected item for more information shown on the LCD display.
9	LAN 2	The cable that connects the unit to the Internet, LAN, WAN, or to cascade up to 64 PG PDUs plugs in here.
10	sensor port	Connects the RJ-45 port to a humidity and temperature sensor (e.g. EA1640).
11	reset button	This button is recessed and must be pushed with a thin object, such as the end of a paper clip. Press and release to reboot the device.

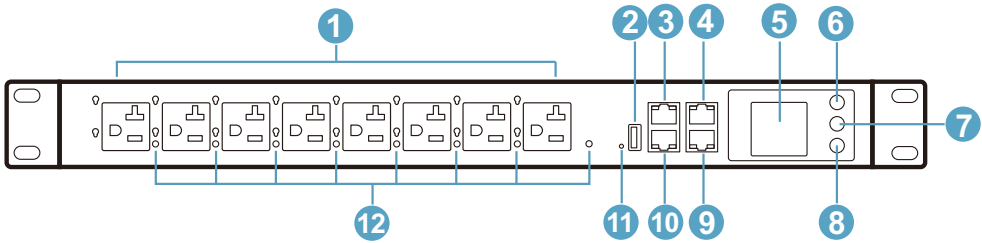
PG6308A / PG8308A Front View

No.	Item	Description
1	power outlets	8 × NEMA 5-20R Note: Holes for ATEN Lok-U-Plug cable holders are located around the outlets. See <i>Securing the Cables</i> , page 23, for further information.
2	USB Type-A port	Connects to a USB Type-A storage device for firmware upgrade or log export. <ul style="list-style-type: none"> ◆ USB firmware upgrade: The eco PDUs support quickly firmware upgrade through USB port. ◆ USB setting & log file restored: Users can export the setting and the log file through USB.
3	COM + PON port	<ul style="list-style-type: none"> ◆ COM: Connects to a hardware or software controller for remote control. ◆ PON: Connects to KN series for cascading up to 16 PG PDUs.
4	LAN 1	The cable that connects the unit to the Internet, LAN, WAN, or to cascade up to 64 PG PDUs plugs in here.
5	LCD panel	When PDU / Bank / Outlet is selected, readouts for its current, voltage, power, and IP address appear in the display window.
6	menu / back button	Press the button to return to the previous page on the LCD display. Press and hold the button for 2 seconds to go back to the main menu.

No.	Item	Description
7	select button	Press the button to cycle the selection between the items; the LCD display indicates which one is currently displayed.
8	enter button	Press the button to enter the page of the selected item for more information shown on the LCD display.
9	LAN 2	The cable that connects the unit to the Internet, LAN, WAN, or to cascade up to 64 PG PDUs plugs in here.
10	sensor port	Connects the RJ-45 port to a humidity and temperature sensor (e.g. EA1640).
11	reset button	This button is recessed and must be pushed with a thin object, such as the end of a paper clip. Press and release to reboot the device.
12	outlet status LEDs	These LEDs indicate outlet status. Lights green for powered on. Off for powered off.

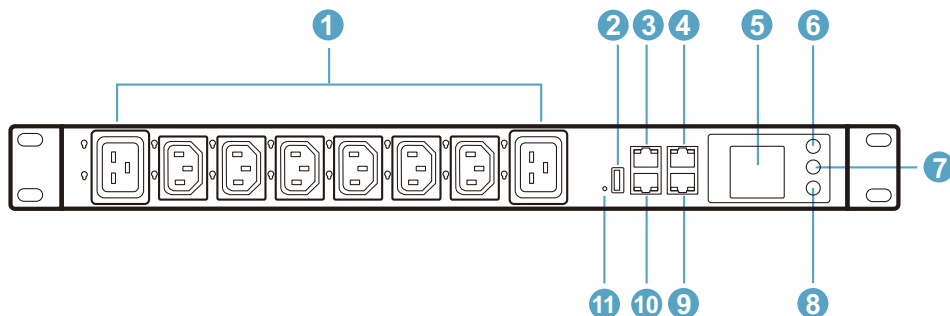
PG5308B / PG5308G Front View

No.	Item	Description
1	power outlets	8 in total: 6 × IEC60320 C13 2 × IEC60320 C19 Note: Holes for ATEN Lok-U-Plug cable holders are located around the outlets. See <i>Securing the Cables</i> , page 23, for further information.
2	USB Type-A port	Connects to a USB Type-A storage device for firmware upgrade or log export. <ul style="list-style-type: none"> USB firmware upgrade: The eco PDUs support quickly firmware upgrade through USB port. USB setting & log file restored: Users can export the setting and the log file through USB.
3	COM + PON port	<ul style="list-style-type: none"> COM: Connects to a hardware or software controller for remote control. PON: Connects to KN series for cascading up to 16 PG PDUs.
4	LAN 1	The cable that connects the unit to the Internet, LAN, WAN, or to cascade up to 64 PG PDUs plugs in here.

No.	Item	Description
5	LCD panel	When PDU / Bank / Outlet is selected, readouts for its current, voltage, power, and IP address appear in the display window.
6	menu / back button	Press the button to return to the previous page on the LCD display. Press and hold the button for 2 seconds to go back to the main menu.
7	select button	Press the button to cycle the selection between the items; the LCD display indicates which one is currently displayed.
8	enter button	Press the button to enter the page of the selected item for more information shown on the LCD display.
9	LAN 2	The cable that connects the unit to the Internet, LAN, WAN, or to cascade up to 64 PG PDUs plugs in here.
10	sensor port	Connects the RJ-45 port to a humidity and temperature sensor (e.g. EA1640).
11	reset button	This button is recessed and must be pushed with a thin object, such as the end of a paper clip. Press and release to reboot the device.

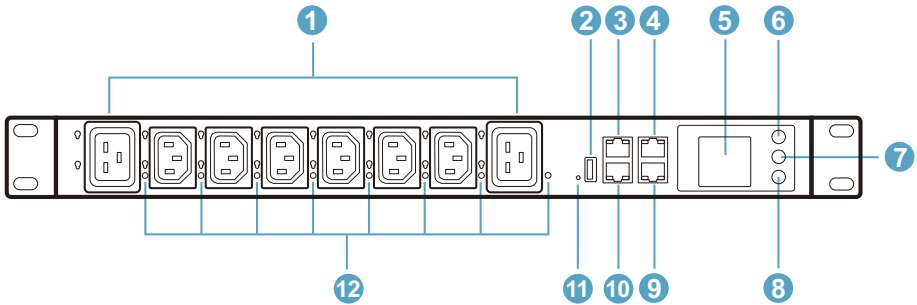
PG6308B / PG6308G / PG8308B / PG8308G Front View

No.	Item	Description
1	power outlets	8 in total: 6 × IEC60320 C13 2 × IEC60320 C19 Note: Holes for ATEN Lok-U-Plug cable holders are located around the outlets. See <i>Securing the Cables</i> , page 23, for further information.
2	USB Type-A port	Connects to a USB Type-A storage device for firmware upgrade or log export. <ul style="list-style-type: none"> USB firmware upgrade: The eco PDUs support quickly firmware upgrade through USB port. USB setting & log file restored: Users can export the setting and the log file through USB.
3	COM + PON port	<ul style="list-style-type: none"> COM: Connects to a hardware or software controller for remote control. PON: Connects to KN series for cascading up to 16 PG PDUs.
4	LAN 1	The cable that connects the unit to the Internet, LAN, WAN, or to cascade up to 64 PG PDUs plugs in here.

No.	Item	Description
5	LCD panel	When PDU / Bank / Outlet is selected, readouts for its current, voltage, power, and IP address appear in the display window.
6	menu / back button	Press the button to return to the previous page on the LCD display. Press and hold the button for 2 seconds to go back to the main menu.
7	select button	Press the button to cycle the selection between the items; the LCD display indicates which one is currently displayed.
8	enter button	Press the button to enter the page of the selected item for more information shown on the LCD display.
9	LAN 2	The cable that connects the unit to the Internet, LAN, WAN, or to cascade up to 64 PG PDUs plugs in here.
10	sensor port	Connects the RJ-45 port to a humidity and temperature sensor (e.g. EA1640).
11	reset button	This button is recessed and must be pushed with a thin object, such as the end of a paper clip. Press and release to reboot the device.
12	outlet status LEDs	These LEDs indicate outlet status. Lights green for powered on. Off for powered off.

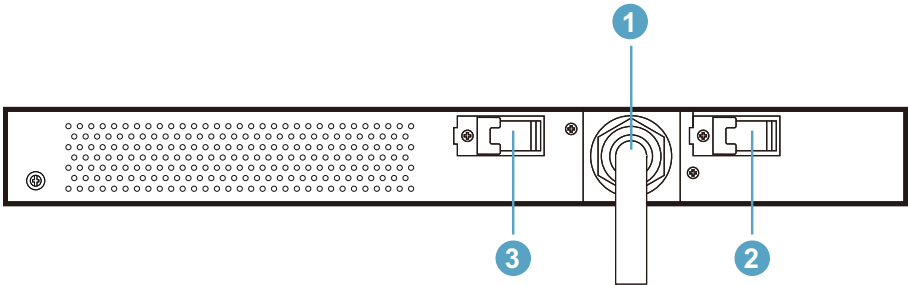
PG5308 / PG6308 / PG8308 Rear View

No.	Item	Description
1	power cord	Connects the unit to an AC power source.
2	circuit breaker for outlet 1–4	As a safety measure, if there is an overcurrent situation in regards to the device's power, the circuit breakers will trip. Press the button to recover normal operation. Warning: See <i>Resetting the Circuit Breaker</i> , page 127 for important information about resetting a tripped circuit breaker.
3	circuit breaker for outlet 5–8	

PG8208G Front View

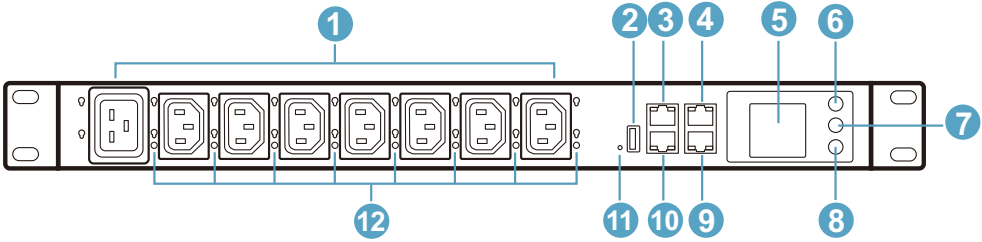

No.	Item	Description
1	power outlets	8 in total: 7 × IEC320 C13 1 × IEC320 C19 Note: Holes for ATEN Lok-U-Plug cable holders are located around the outlets. See <i>Securing the Cables</i> , page 23, for further information.
2	USB Type-A port	Connects to a USB Type-A storage device for firmware upgrade or log export. <ul style="list-style-type: none"> ◆ USB firmware upgrade: The eco PDUs support quickly firmware upgrade through USB port. ◆ USB setting & log file restored: Users can export the setting and the log file through USB.
3	COM + PON port	<ul style="list-style-type: none"> ◆ COM: Connects to a hardware or software controller for remote control. ◆ PON: Connects to KN series for cascading up to 16 PG PDUs.
4	LAN 1	The cable that connects the unit to the Internet, LAN, WAN, or to cascade up to 64 PG PDUs plugs in here.
5	LCD panel	When PDU / Bank / Outlet is selected, readouts for its current, voltage, power, and IP address appear in the display window.

No.	Item	Description
6	menu / back button	Press the button to return to the previous page on the LCD display. Press and hold the button for 2 seconds to go back to the main menu.
7	select button	Press the button to cycle the selection between the items; the LCD display indicates which one is currently displayed.
8	enter button	Press the button to enter the page of the selected item for more information shown on the LCD display.
9	LAN 2	The cable that connects the unit to the Internet, LAN, WAN, or to cascade up to 64 PG PDUs plugs in here.
10	sensor port	Connects the RJ-45 port to a humidity and temperature sensor (e.g. EA1640).
11	reset button	This button is recessed and must be pushed with a thin object, such as the end of a paper clip. Press and release to reboot the device.
12	outlet status LEDs	These LEDs indicate outlet status. Lights green for powered on. Off for powered off.

PG8208G Rear View

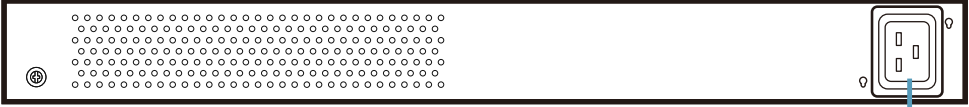

No.	Item	Description
1	power inlet	Plugs the supplied power cord to the PG8208G's power inlet, and then connects it to the external power source.

Chapter 2

Hardware Setup

Before You Begin



1. Important safety information regarding the placement of this device is provided on page 123. Please review it before proceeding.
2. Make sure that power to all the devices you will be connecting have been turned off. You must unplug the power cords of any computers that have the Keyboard Power On function.
3. See *Resetting the Circuit Breaker*, page 127 for important information about resetting a tripped circuit breaker.

Rack Mount

To mount the unit onto a 19" (1U) system rack:

1. Attach the two mounting brackets onto the sides of the unit with the screws that provided.

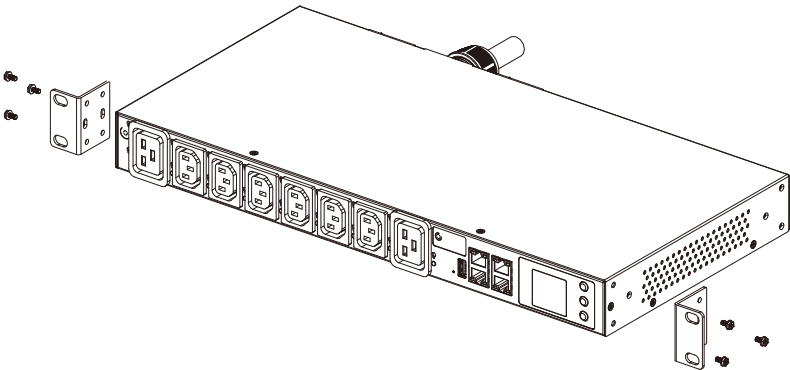

2. Align the mounting brackets' screw holes with that of the front of the rack, and secure the unit onto the rack using self-supplied screws.

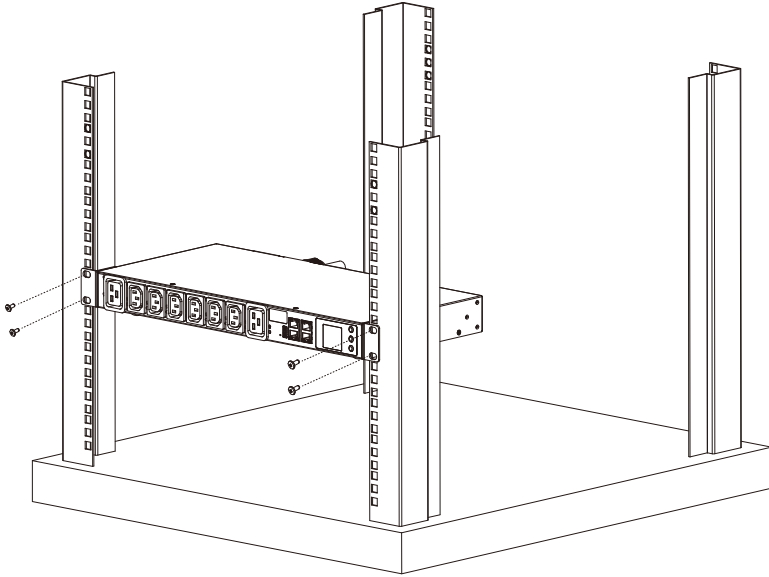

Installation

To set up your installation, refer to the installation diagram below (the numbers in the diagram correspond to the numbered steps), and do the following:

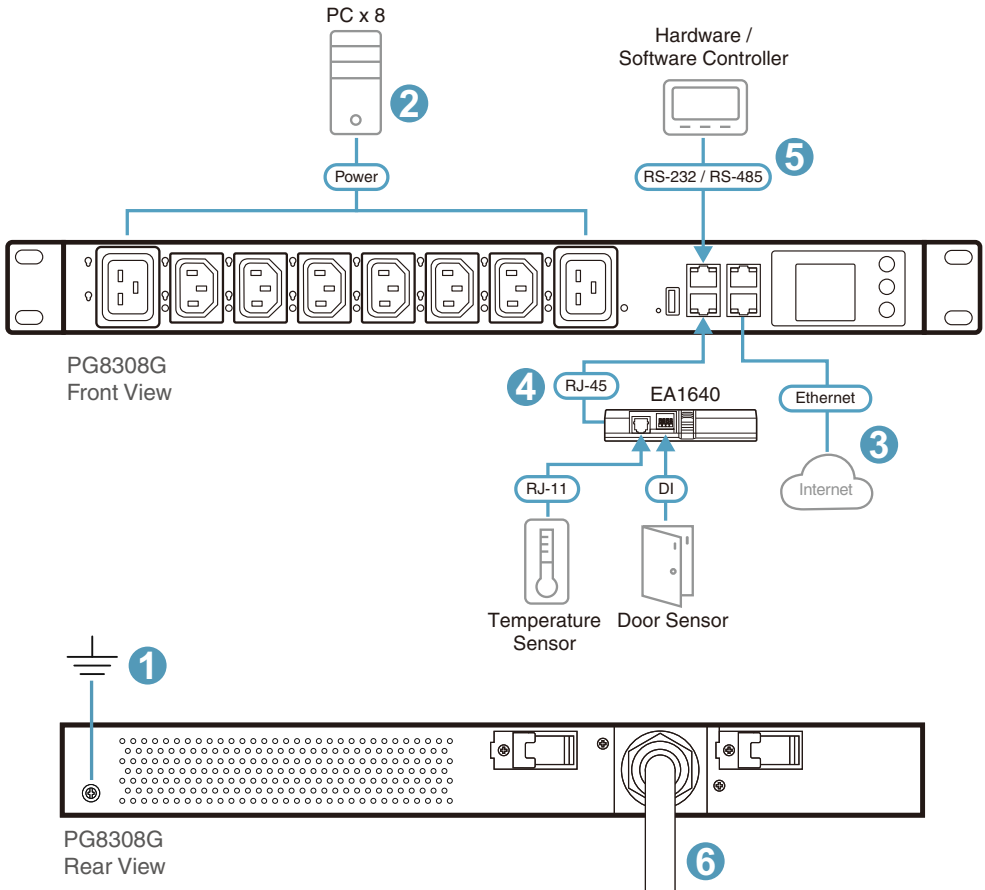

1. Make sure the unit is properly grounded.

Note: Do not omit this step. Proper grounding helps prevent damage to the unit from power surges or static electricity.

2. For each device you want to connect, use its power cable to connect the device's AC power inlet to any available outlet on the eco PDU. Use ATEN Lok-U-Plug cable holders to secure them.
3. Connect the unit's LAN 1 or LAN 2 port to a network using an Ethernet cable. For network redundancy, optionally connect both LAN ports to the network using 2 Ethernet cables.

Note: You can also use the LAN ports to cascade up to 64 eco PDUs.

4. (Optional) Connect an environmental sensor (ATEN EA1640 Temperature & Humidity Sensor) to the unit's sensor port.
5. (Optional) Connect an RS-232/RS-485 serial controller to the unit's COM port.

Note: You can also use the port as a PON port, connecting to an ATEN KVM over IP Switch via an Ethernet cable.

6. Connect the unit's built-in power cord to an AC power source, thereby turning it on, and then turn on the connected devices.

Note: Plug the supplied power cord to the PG8208G's power inlet, and then connect it to the external power source.

Once you have finished these installation steps, you can turn on the eco PDU and the connected devices.

Securing the Cables

For added safety, use ATEN Lok-U-Plug cable holders to secure the cables of your powered devices in place on the eco PDU. Secure the cable holders using the specially designed holes around the individual power outlets, as shown below:

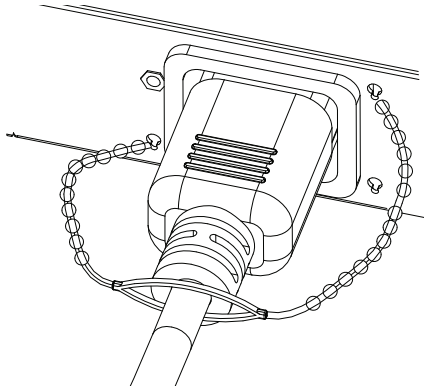

-
- Note:** 1. Cable holders are not included with the device and must be purchased separately. See *Cable Holders*, page 6.
2. Only the ATEN Lok-U-Plug cable holders that have been specifically designed to work with the eco PDU can be used. Using any other kinds of cable securing device could potentially result in irreversible damage or harm to the device or users.
-

RS-232 Command List

Please refer to the table and figure below for the RS-232 management and the list of commands.

DB-9	CON	RS-232
3	RS-232 RX	3
5	GND	5
2	RS-232 TX RS-485 D+	6
1	RS-485 D-	8

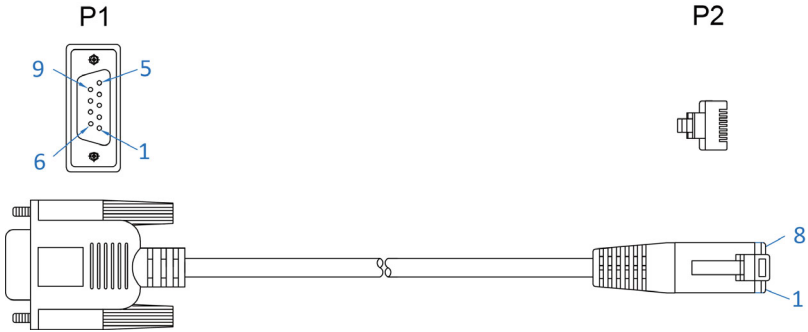

Wire Table		
P1	Color	P2
3	Black	3
5	Brown	5
2	Red	6
1	Orange	8

Cascade & Bridge

Follow the steps described in the sections below to cascade / bridge your eco PDUs.

Cascade

To cascade multiple ATEN eco PDUs, all the units must be in the same network segment. The cascaded devices can be with different IP addresses.

Note: To cascade your devices with one set of IP address, please connect all your units through either LAN 1 port or LAN 2 port.

1. Log in to your master unit via the supported browser.
2. Go to **Setup** > **Cascade** to set the other units. See *Cascade*, page 80 for details.

Bridge

To bridge multiple ATEN eco PDUs, all the eco PDUs should be installed and connected on the same location, and the units should be with the same IP address.

Note: If you'd like to set the master unit and the slave units, please disable the function "Bridge" for your master unit through the unit's LCD menu while all the other slave units' Bridge function are enabled. See *Bridge*, page 108 for details.

- ◆ To save IP from switch router and use Intranet to share LAN, please connect your eco PDUs as the steps below:
 1. Connect the first (master) unit's LAN 1 port to switch router.
 2. Connect the first unit's LAN 2 port to LAN 1 port of the second unit (slave unit).
 3. Connect the LAN 1 port and LAN 2 port of the second unit.
 4. Connect the second unit's LAN 2 port to LAN 1 port of the next unit (slave unit).

5. Repeat the procedures similar to step 3 and step 4 to connect other slave units to complete your installation.
- ◆ To use one set of IP address from switch router, connect your eco PDUs as the steps below:
 1. Connect the first (master) unit's LAN 1 port to switch router.
 2. Connect the first unit's LAN 1 port to its LAN 2 port.
 3. Connect the first unit's LAN 2 port to LAN 1 port of the second unit (slave unit).
 4. Connect the LAN 1 port and LAN 2 port of the second unit.
 5. Connect the second unit's LAN 2 port to LAN 1 port of the next unit (slave unit).
 6. Repeat the procedures similar to step 4 and step 5 to connect other slave units to complete your installation.

Note: The last slave unit cannot be connected to any switch router.

Concatenate eco PDUs by Bridge and Cascade

To concatenate multiple eco PDUs with one set of IP address:

1. Through the LCD menu, disable the function **Bridge** for your master unit while all the other slave units' Bridge function are enabled.
2. Follow the steps in *Bridge*, page 25 to connect the units.
3. Log in to your master unit via a supported Internet browser, go to **Setup > Cascade**, and add your slave units on the sub LAN to the master unit. See *Cascade*, page 80 for details.

Note: The last slave unit cannot connected to any switch router.

Chapter 3

Basic Operation and First-Time Setup

Operation Methods

ATEN eco PDU models provide three methods to be accessed and managed: Browser, eco DC (Energy & DCIM management web GUI), and SNMP.

Note: The following sections of this chapter contain information concerning Browser operation. For eco DC operation, please refer to the eco DC user manual. The eco DC and user manual can be downloaded from the ATEN website.

Browser

ATEN eco PDUs can be accessed and controlled via any supported Internet browser from any platform. See *First-Time Setup*, page 28, and the following sections in this chapter, for full details.

eco DC

All eco PDUs support eco DC (Energy & DCIM management web GUI). ATEN eco DC provides you with an easy method for managing multiple devices, offering an intuitive and user-friendly Graphical User Interface that allows you to configure a PDU device and monitor power status of the equipment connected to it. ATEN eco DC can be downloaded from the ATEN website, along with a separate eco DC user manual.

SNMP

ATEN eco PDUs support any 3rd-party V1, V2, V3 SNMP manager software. SNMP Management Information Database (MIB) files for the eco PDU device can be found on the software and downloaded from the ATEN website.

First-Time Setup

Once the eco PDU installation and connections have been completed, the administrator shall start configuring its network parameters, including changing, the default administrator login settings, and adding users.

The easiest way to accomplish this is to log in to it with a browser using a PC within the same LAN.

- Note:**
1. Since this is the first time you are logging in, use the default username and password *administrator* and *password*. For security purposes, users should change the login credentials to something unique after logging in (see *Changing the Administrator Login*, page 30).
 2. For remote methods of getting logged into the network, see *IP Address Determination*, page 129.

After you successfully log in, the eco PDU Energy/Connections page appears.

Connections | Configuration | Sensor Config

Station List

- [C01] - [PG8308G] PG8308G
- [01]
- [02]
- [03]
- [04]
- [05]
- [06]
- [07]
- [08]

PDU Status

PDU Name	Measurement	Min Threshold	Max Threshold	PDU Status
PG8308G	Aggregate current	0.00 A		<input type="radio"/> ON <input checked="" type="radio"/> OFF <input type="checkbox"/> Reboot
	Voltage	108.27 V		
	Power	0.0000 W		
	Aggregate power dissipation	0.0034 KWH		

Environment Sensor Status

No.	Name	Model	Measurement
No Sensor Hub Added			

Bank Status

Bank	Bank Name	Measurement	Min Threshold	Max Threshold	Bank Status
[01]		Current	0.00 A		<input type="radio"/> ON <input checked="" type="radio"/> OFF <input type="checkbox"/> Reboot
		Voltage	108.27 V		
		Power	0.0000 W		
		Power Dissipation	0.0034 KWH		
		Voltage frequency	60.00 Hz		
		Breaker	ON		
		Current	0.00 A		

© Copyright 2022 ATEN @ International Co., Ltd.

Note: Operation details are discussed in the next chapter. For further setup information, continue with this chapter

Network Configuration

To set up the network, do the following:

1. Click the **Setup**. The **Device Configuration** page, similar to the one below, appears.

The screenshot displays the ATEN PG8308G Device Configuration interface. The top navigation bar includes icons for Energy, User, Log, Setup (highlighted), and PDU. Below the navigation bar, the page title is 'Device Configuration' with sub-links for Security, Wireless Network, Cascade, Rules, Scheduler, and Python Script. On the left, a 'Station List' shows a tree view with 'PG8308G' expanded to show items [01] through [08]. The main configuration area is titled 'General' and contains the following fields:

- PDU Name: PG8308G
- MAC Address: 00:10:74:25:DD:22
- MAC Address: 00:10:74:25:DD:23
- Firmware Version: 1.0.092
- Rack Location name: [Empty field]

The 'Service Ports' section includes radio buttons for 'Only HTTPS' (selected) and 'HTTP / HTTPS'. Below these are input fields for HTTP (80) and HTTPS (443).

The 'Serial Settings' section includes dropdown menus for Console Mode (RS232) and RS485Serial Port Address (01).

© Copyright 2022 ATEN @ International Co., Ltd.

2. Fill in the fields according to the information provided under *Device Configuration*, page 58.

Changing the Administrator Login

To change the default administrator username and password, do the following:

1. Click **User**.

Once users have been added to the system, the Accounts page displays a detailed list of users—with more information about them in the large central panel:

Administrator information

Administrator:

Name: Password:

SNMPv3 account information

Name: Auth-password: Priv-Password:

SNMPv1/v2c community

Read community: Write community:

Telnet

Name: Password:

SSH

Name: Password:

User information

ManagementName	Password	[C01]Outlet								
		All	01	02	03	04	05	06	07	08
Disable ▾		✕	✕	✕	✕	✕	✕	✕	✕	✕
Disable ▾		✕	✕	✕	✕	✕	✕	✕	✕	✕
Disable ▾		✕	✕	✕	✕	✕	✕	✕	✕	✕
Disable ▾		✕	✕	✕	✕	✕	✕	✕	✕	✕
Disable ▾		✕	✕	✕	✕	✕	✕	✕	✕	✕
Disable ▾		✕	✕	✕	✕	✕	✕	✕	✕	✕
Disable ▾		✕	✕	✕	✕	✕	✕	✕	✕	✕
Disable ▾		✕	✕	✕	✕	✕	✕	✕	✕	✕

2. In the **Administrator Information** section at the top, reset the name and password fields to something unique, then click **Save** (at the bottom of the page.)

Moving On

After setting up the network and changing the default administrator username and password, you can proceed to other administration activities, including adding users, which is covered in the next chapter.

This Page Intentionally Left Blank

Chapter 4

Logging In

Logging In

The eco PDU can be accessed via a supported Internet browser from any platform.

Note: Browsers must support TLS 1.0.

To access the eco PDU do the following:

1. Open your browser and specify the IP address of the eco PDU you want to access in the browser's URL location bar.

Note: You can get the IP address from the eco PDU administrator, or see *IP Address Determination*, page 129, for information about setting it up yourself.

2. If a security alert dialog box appears, accept the certificate—it can be trusted. The login page appears.

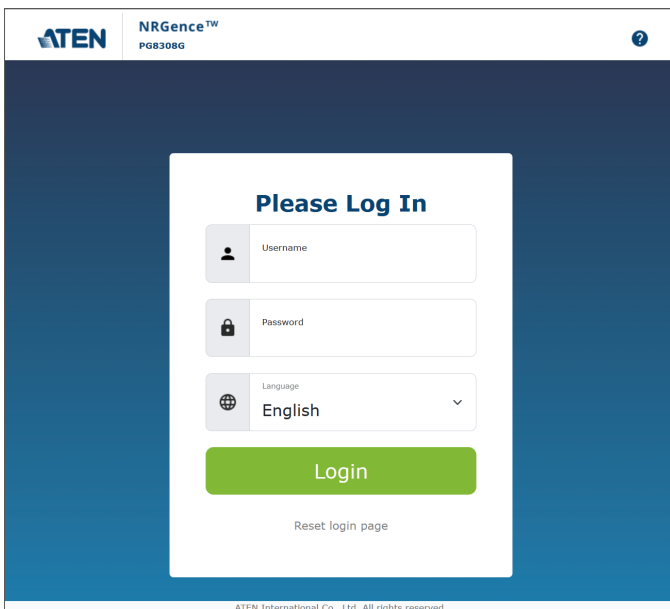

The screenshot shows the login interface for the ATEN NRGence™ PG8308G. The header includes the ATEN logo and the product name. The main content area is a white box with a green 'Login' button and a 'Reset login page' link. The login form includes fields for Username, Password, and Language (set to English).

3. Provide a valid **Username** and **Password** (set by the eco PDU administrator).
4. Select your preferred **Language** from the drop-down menu.
5. Click **Login** to bring up the browser main page.

The eco PDU Main Page

After you have successfully logged in, the eco PDU main page comes up with the Energy *Connections* page displayed:

The screenshot shows the ATEN eco PDU main page. The top navigation bar includes 'Energy', 'User', 'Log', 'Setup', and 'PDU' buttons. The main content area is divided into several sections: 'Station List', 'PDU Status', 'Environment Sensor Status', 'Bank Status', and 'Outlet Status'. Callouts 1 through 6 point to specific elements: 1 points to the ATEN logo, 2 to the 'Connections' tab, 3 to the 'Station List' on the left, 4 to the help icon, 5 to the refresh icon, and 6 to the 'Reboot' button in the PDU Status table.

Station List

Station	Name
[01]	PGS308G
[02]	PGS308G
[03]	PGS308G
[04]	PGS308G
[05]	PGS308G
[06]	PGS308G
[07]	PGS308G
[08]	PGS308G

PDU Status

PDU Name	Measurement	Min Threshold	Max Threshold	PDU Status
PGS308G	Aggregate current	0.00 A		ON OFF <input type="checkbox"/> Reboot
	Voltage	108.25 V		
	Power	0.0000 W		
	Aggregate power dissipation	0.0034 KWH		

Environment Sensor Status

No.	Name	Model	Measurement
No Sensor Hub Added			

Bank Status

Bank	Bank Name	Measurement	Min Threshold	Max Threshold	Bank Status
[01]		Current	0.00 A		ON OFF <input type="checkbox"/> Reboot
		Voltage	108.25 V		
		Power	0.0000 W		
		Power Dissipation	0.0034 KWH		
		Voltage frequency	59.99 Hz		
		Breaker	ON		
[02]		Current	0.00 A		ON OFF <input type="checkbox"/> Reboot
		Voltage	108.27 V		
		Power	0.0000 W		
		Power Dissipation	0.0000 KWH		
		Voltage frequency	59.97 Hz		
		Breaker	ON		

Outlet Status

Outlet	Outlet Name	Auto Ping Status	Measurement	Min Threshold	Max Threshold	Outlet Status	Outlet Switching
--------	-------------	------------------	-------------	---------------	---------------	---------------	------------------

© Copyright 2022 ATEN @ International Co., Ltd.

Note: The screen depicts an administrator’s page. Depending on the type of user logged in and its permissions, and your PG model, not all of these elements may appear.

Page Components

The web page screen components are described in the table below:

No.	Item	Description
1	Tab Bar	The tab bar contains the eco PDU's main operation categories. The items that appear in the tab bar are determined by the user's type, and the setting permissions that were selected when the user's account was created.
2	Menu Bar	The menu bar contains operational subcategories within the item selected on the tab bar. The items that appear in the menu bar are determined by the user's type, and the setting permissions that were selected when the user's account was created.
3	Sidebar	The sidebar provides a tree view listing of outlets that relate to the various tab bar and menu bar selections.
4	Help	Connects to the online help section on the ATEN website for the device's configuration and operation.
5	Logout	Click this button to log out of your eco PDU session.
6	Interactive Display Panel	This is your main work area. The screens that appear reflect your menu choices and the sidebar node selection.

The Energy page has the following tabs: *Connections*, *Configuration*, and *Sensor Config*, as described in the chapters that follow.

This Page Intentionally Left Blank

Chapter 5 Energy

Connection

When you log in to the eco PDU, the interface opens with its default selection of *Energy > Connections*, with the **PDU Status**, **Sensor Status**, **Bank Status**, and **Outlet Status** sections displayed in the main panel.

ATEN PG8308G

Energy User Log Setup PDU

Connections | Configuration | Sensor Config

Station List

- [01] PG8308G | PG8308G

PDU Status

PDU Name	Measurement	Min Threshold	Max Threshold	PDU Status
PG8308G	Aggregate current	0.00 A		ON OFF <input type="checkbox"/> Reboot
	Voltage	108.85 V		
	Power	0.0000 W		
	Aggregate power dissipation	0.0034 KWH		

Environment Sensor Status

No.	Name	Model	Measurement
No Sensor Hub Added			

Bank Status

Bank	Bank Name	Measurement	Min Threshold	Max Threshold	Bank Status
[01]		Current	0.00 A		ON OFF <input type="checkbox"/> Reboot
		Voltage	108.85 V		
		Power	0.0000 W		
		Power Dissipation	0.0034 KWH		
		Voltage frequency	60.09 Hz		
		Breaker	ON		
[02]		Current	0.00 A		ON OFF <input type="checkbox"/> Reboot
		Voltage	108.87 V		
		Power	0.0000 W		
		Power Dissipation	0.0000 KWH		
		Voltage frequency	60.02 Hz		
		Breaker	ON		

Outlet Status

Outlet/Outlet Name	Auto Ping Status	Measurement	Min Threshold	Max Threshold	Outlet Status	Outlet Switching
[01]	N/A	Current	0.00 A		OFF	ON OFF <input type="checkbox"/> Reboot
		Voltage	0.00 V			
		Power	0.0000 W			
		Power Dissipation	0.0000 KWH			
		Power factor	1.00			
[02]	N/A	Current	0.00 A		ON	ON OFF <input type="checkbox"/> Reboot
		Voltage	108.85 V			
		Power	0.0000 W			
		Power Dissipation	0.0000 KWH			
		Power factor	1.00			
[03]	N/A	Current	0.00 A		ON	ON OFF <input type="checkbox"/> Reboot
		Voltage	108.85 V			
		Power	0.0000 W			

Power Dissipation: 0.0034 KWH

© Copyright 2022 ATEN @ International Co., Ltd.

PDU Status

All eco PDU models support PDU device level monitoring. The **PDU Status** section allows you to set up a power management configuration for the PDU device as a whole:

PDU Status					
PDU Name	Measurement		Min Threshold	Max Threshold	PDU Status
PG8308G	Aggregate current	0.00 A	<input type="text"/>	<input type="text"/>	<input type="button" value="ON"/> <input type="button" value="OFF"/> <input type="checkbox"/> Reboot
	Voltage	108.67 V	<input type="text"/>	<input type="text"/>	
	Power	0.0000 W	<input type="text"/>	<input type="text"/>	
	Aggregate power dissipation	0.0034 KWH	<input type="text"/>	<input type="text"/>	

◆ PDU Threshold Settings

These fields are used to set the maximum threshold settings for the Power, and Aggregate Power Dissipation. If any of them falls below the minimum setting or exceeds the maximum setting, an alarm is triggered.

◆ On / Off / Reboot

You can manually turn the device on or off from this page by clicking the ON / OFF buttons. To Reboot the device, enable the *Reboot* checkbox and click **OFF** (reboot only works on the eco PDUs with PDU Outlet Status ON).

Note: PG5308 does not support On / Off / Reboot functions.

Environment Sensor Status

All eco PDU models support sensor monitoring. The **Sensor Status** section allows you to set up a sensor management configuration for the PDU device:

Sensor Status				
Sensor Port	Address	Temperature	Humidity	Pressure
Sensor1	1	N/A	N/A	N/A
	Max Threshold	40.0	<input type="text"/>	<input type="text"/>
	Min Threshold	30.0	<input type="text"/>	<input type="text"/>

◆ Sensor 1

If you have sensors installed in your installation, use these fields to set the maximum and minimum threshold settings for Temperature, Humidity, and/or Pressure.

To add a sensor to be monitored, click on the search button  to open the Search Device popup window, and follow the on-screen instruction to complete.

Note: Sensors are optional accessories. Check with your dealer for details.

Bank Status

All eco PDU models support Bank level monitoring. The **Bank Status** section allows you to set up a power management configuration for each of the individual banks:

Bank Status						
Bank	Bank Name	Measurement	Value	Min Threshold	Max Threshold	Bank Status
[01]		Current	0.00 A	<input type="text"/>	<input type="text"/>	<input type="button" value="ON"/> <input type="button" value="OFF"/> <input type="checkbox"/> Reboot
		Voltage	109.50 V	<input type="text"/>	<input type="text"/>	
		Power	0.0000 W	<input type="text"/>	<input type="text"/>	
		Power Dissipation	0.0034 KWH	<input type="text"/>	<input type="text"/>	
		Voltage frequency	60.06 Hz	<input type="text"/>	<input type="text"/>	
		Breaker	ON	<input type="text"/>	<input type="text"/>	
[02]		Current	0.00 A	<input type="text"/>	<input type="text"/>	<input type="button" value="ON"/> <input type="button" value="OFF"/> <input type="checkbox"/> Reboot
		Voltage	109.53 V	<input type="text"/>	<input type="text"/>	
		Power	0.0000 W	<input type="text"/>	<input type="text"/>	
		Power Dissipation	0.0000 KWH	<input type="text"/>	<input type="text"/>	
		Voltage frequency	60.02 Hz	<input type="text"/>	<input type="text"/>	
		Breaker	ON	<input type="text"/>	<input type="text"/>	

◆ Threshold Settings

These fields are used to set the maximum and minimum threshold settings for the Aggregate Current, Voltage, Power, and Power Dissipation. If any of them falls below the minimum setting or exceeds the maximum setting, an alarm is triggered.

- ◆ **Voltage Frequency** is displayed here in Hz.
- ◆ **Breaker** status (ON / OFF) displays here.

Note: This function is inapplicable to PG8208G.

◆ On / Off / Reboot

You can manually turn the device on or off from this page by clicking the ON / OFF buttons. To Reboot the device, enable the *Reboot* checkbox and click **OFF** (reboot only works on the eco PDUs with Bank Outlet Status ON).

Note: PG5308 does not support On / Off / Reboot functions.

Outlet Status

Only PG8208G and PG8308 series support Outlet level monitoring. The **Outlet Status** section allows you to set up a power management configuration for each of the individual outlets:

Outlet Status								
Outlet	Outlet Name	Auto Ping Status	Measurement	Min Threshold	Max Threshold	Outlet Status	Outlet Switching	
[01]		N/A	Current	0.00 A	<input type="text"/>	<input type="text"/>	OFF	<input type="button" value="ON"/> <input type="button" value="OFF"/> <input type="checkbox"/> Reboot
			Voltage	0.00 V	<input type="text"/>	<input type="text"/>		
			Power	0.0000 W	<input type="text"/>	<input type="text"/>		
			Power Dissipation	0.0000 KWH	<input type="text"/>	<input type="text"/>		
			Power factor	1.00	<input type="text"/>	<input type="text"/>		
[02]		N/A	Current	0.00 A	<input type="text"/>	<input type="text"/>	ON	<input type="button" value="ON"/> <input type="button" value="OFF"/> <input type="checkbox"/> Reboot
			Voltage	108.72 V	<input type="text"/>	<input type="text"/>		
			Power	0.0000 W	<input type="text"/>	<input type="text"/>		
			Power Dissipation	0.0000 KWH	<input type="text"/>	<input type="text"/>		
			Power factor	1.00	<input type="text"/>	<input type="text"/>		
[03]		N/A	Current	0.00 A	<input type="text"/>	<input type="text"/>	ON	<input type="button" value="ON"/> <input type="button" value="OFF"/> <input type="checkbox"/> Reboot
			Voltage	108.72 V	<input type="text"/>	<input type="text"/>		
			Power	0.0000 W	<input type="text"/>	<input type="text"/>		
			Power Dissipation	0.0034 KWH	<input type="text"/>	<input type="text"/>		
			Power factor	1.00	<input type="text"/>	<input type="text"/>		

◆ Threshold Settings

These fields are used to set the maximum and minimum threshold settings for the Aggregate Current, Voltage, Power, and Power Dissipation. If any of them falls below the minimum setting or exceeds the maximum setting, an alarm is triggered.

◆ Outlet Status

Indicates each outlet status (ON / OFF / POP).

◆ On / Off / Reboot

You can manually turn the outlet on or off from this page by clicking the ON / OFF buttons. To Reboot the device, enable the *Reboot* checkbox and click **OFF** (reboot only works on the eco PUDs with Outlet Status ON).

Configuration

The *Configuration* page is used to configure the settings of the eco PDU at the bank and individual power outlet level:

The screenshot shows the ATEN PG8308G Configuration page. The top navigation bar includes 'Energy', 'User', 'Log', 'Setup', and 'PDU'. The main content area is titled 'Configuration | Sensor Config' and features a 'Station List' on the left with outlets [01] through [08]. The main configuration area is divided into several sections:

- POP Settings:** Contains three checkboxes: 'Enable Outlet POP' (checked), 'Enable Bank POP LIFO Mode' (checked), and 'Enable Bank POP Priority Mode' (unchecked).
- Power On Time Schedule Settings:** Contains one checkbox: 'Enable Power On Time Schedule' (unchecked).
- Bank Configuration:** A table with columns 'Bank' and 'Bank Name'. It shows two banks, [01] and [02], with empty 'Bank Name' fields.
- Bank POP Priority List:** A table with columns 'Bank 1' and 'Bank 2'. It lists priority outlets for each bank:

Bank 1	Bank 2
Priority1 Outlet 1	Priority1 Outlet 5
Priority2 Outlet 2	Priority2 Outlet 6
Priority3 Outlet 3	Priority3 Outlet 7

© Copyright 2022 ATEN @ International Co., Ltd.

POP Settings

This section allows you to configure the settings for ATEN's exclusive Proactive Overload Protection (POP) technology. Effective on all non-critical outlets, this added safety feature automatically powers off when a current overload occurs. Check the checkbox and click Save to enable the selected POP mode(s).

POP Settings

Enable Outlet POP

Enable Bank POP LIFO Mode

Enable Bank POP Priority Mode

- ◆ **Enable Outlet POP Mode:** Automatically powers off the outlets when a current overload occurs.
- ◆ **Enable Bank POP LIFO Mode:** Automatically powers off the outlets in a last-in first-out sequence when a current overload occurs.

- ◆ **Enable Bank POP Priority Mode:** Automatically powers off the outlets according to a pre-configured Bank POP Priority List. See *Bank POP Priority List*, **page 42**.

Note: PG5308 does not support POP function.

Power On Time Schedule Settings

Check the Enable Power On Time Schedule box to use the Power ON Delay setting to set the amount of time the eco PDU waits before powering on an outlet. See Power ON Delay in the table on the next page.

Power On Time Schedule Settings

Enable Power On Time Schedule

Note: PG5308 does not support Enable Power On Time Schedule.

Bank Configuration

Each bank can be given a distinctive name (3 banks for PG98230 series, and the maximum number of characters is 15).

Bank Configuration	
Bank	Bank Name
[01]	test
[02]	a01b02c03d04

Bank POP Priority List

This field allows you to set up a POP priority list that the eco PDU powers off the outlets according to sequence configured in this list.

Bank POP Priority List			
Bank 1		Bank 2	
Priority1 Outlet 1	▼	Priority1 Outlet 5	▼
Priority2 Outlet 2	▼	Priority2 Outlet 6	▼
Priority3 Outlet 3	▼	Priority3 Outlet 7	▼
Priority4 Outlet 4	▼	Priority4 Outlet 8	▼

Outlet Configuration

Outlet Configuration lets you set up the power management configuration for the selected outlet. The meanings of the field headings are described in the following table. When you have finished making your configuration settings, click **Save**.

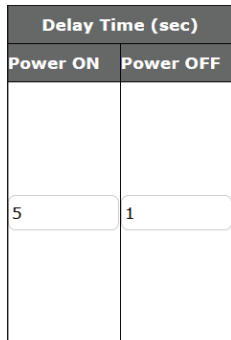
Control/Display	Description
Outlet	Shows the port number of the listed outlet.
Outlet Name	Each outlet can be given a distinctive name. The maximum number of characters is 48.
Confirmation Required	<p>If this option is enabled (there is a check in the checkbox), a dialog box comes up asking you to confirm a power operation before it is performed. If it is disabled (there is no check in the checkbox), the operation is performed without confirmation.</p> 
Delay Time (sec) Power ON	<p>Sets the amount of time the eco PDU waits after the Power Button is clicked (see <i>Outlet Status</i>, page 40), before it turns on the power to the outlet.</p> <p>Note: The default delay time is 5 seconds; the maximum is 999 seconds.</p> 
Delay Time (sec) Power OFF	<p>Sets the amount of time the eco PDU waits after the Power Button is clicked (see <i>Outlet Status</i>, page 40), before it turns off the power to the outlet.</p> <p>The default delay time is 1 seconds. The maximum delay time is 999 seconds.</p>

Control/Display	Description
<p>Remote Turn ON Method</p>	<p>Use the drop-down menu to select one of the choices, below:</p> <div data-bbox="440 199 813 507" style="border: 1px solid black; padding: 10px; margin: 10px 0;"> <p style="text-align: center; background-color: #444; color: white; padding: 5px;">Remote Turn ON Method</p> <p>Method: Kill the Power ▼</p> <p>MAC Address: 000000000000</p> </div> <ul style="list-style-type: none"> <li data-bbox="285 526 968 981"> <p>◆ Wake on LAN</p> <p>This is a safe shutdown and restart option. If this is selected, when an outlet is turned Off, the eco PDU first sends a message to the computer telling it to prepare for a shutdown; it then waits for the amount time set in the <i>Power Off Delay</i> field to give the OS time to close down before the computer is powered down to standby mode.</p> <p>Likewise, when the outlet is turned On, the eco PDU waits for the amount time set in the <i>Power On Delay</i> field, then sends an Ethernet message to the computer connected to the outlet telling the computer to turn itself On.</p> <p>Note: For safe shutdown and restart, the computer must be running Windows (98 or higher), or Linux, and the <i>Safe Shutdown</i> program (available by download from our website), must be installed and running on the computer.</p> <li data-bbox="285 981 968 1380"> <p>◆ System after AC Back</p> <p>This is a safe shutdown and restart option. If this is selected, when an outlet is turned Off, the eco PDU first sends a message to the computer telling it to prepare for a shutdown; it then waits for the amount time set in the <i>Power Off Delay</i> field to give the OS time to close down before the computer is powered down.</p> <p>When the outlet is turned On, the eco PDU waits for the amount time set in the <i>Power On Delay</i> field, then sends power to the server. When the server receives the power, it turns itself on.</p> <p>Note: For safe shutdown and reboot, the computer must be running Windows (98 or higher), or Linux, and the <i>Safe Shutdown</i> program (available by download from our website), must be installed and running on the computer.</p> <p style="text-align: right; margin-top: 20px;"><i>(Continues on next page.)</i></p>

Control/Display	Description
	<p><i>(Continued from previous page.)</i></p> <ul style="list-style-type: none"> ◆ Kill the Power If this option is selected, the eco PDU waits for the amount time set in the <i>Power Off Delay</i> field, and then turns the outlet's power Off. Turning the power off performs a cold (non-safe) shutdown.
MAC Address	In order to use either of the safe shutdown and restart methods, the MAC address of the computer connected to the outlet must be filled in here.
Auto Ping Method	<p><i>Auto Ping Method</i> defines the mechanism which the eco PDU uses to ping a device and to reboot the outlet. To enable this setting, check the Enable checkbox, or check the Disable checkbox to disable.</p> <div data-bbox="390 507 936 826" style="border: 1px solid black; padding: 5px; margin: 10px 0;"> <p>Autoping Monitoring</p> <p> <input type="radio"/> Enable <input checked="" type="radio"/> Disable </p> <p>Outlet control: <input type="radio"/> Enable <input checked="" type="radio"/> Disable</p> <p>Ping interval: <input type="text" value="60"/> sec(s)</p> <p>Wait time before first ping: <input type="text" value="10"/> sec(s)</p> <p>Consecutive failed pings (Reboot outlet): <input type="text" value="1"/> time(s)</p> <p>Max outlet reboot times: <input type="text" value="1"/> time(s)</p> <p>IP Address: <input type="text" value="0.0.0.0"/></p> </div> <ul style="list-style-type: none"> ◆ Outlet Control Enable this setting to reboot the outlet when the eco PDU fails to ping the device for the specified number of times, as set in the Cont. Failed Pings (Reboot Outlet) field. ◆ Ping Interval Enter the number of seconds to elapse between each auto-ping that is sent to test the network device. ◆ Wait Time Before First Ping Enter the duration to wait before the outlet is powered on during a reboot. ◆ Cont. Failed Pings (Reboot Outlet) Enter the maximum number of times that the eco PDU pings the specified device after an initial failure. ◆ Max Outlet Reboot Times Enter the maximum number of times that the eco PDU reboots the specified device after the consecutive pings, as specified in the Cont. Fail Reset field. ◆ IP Address Enter the IP address of the device you want to ping.

Sensor Config

Sensor Config page allows you to configure the alarm for the EA1640 Temperature & Humidity Sensor(s) that connects to the PG8308 unit, and other sensor(s) that connects to the aforementioned EA1640 sensor.

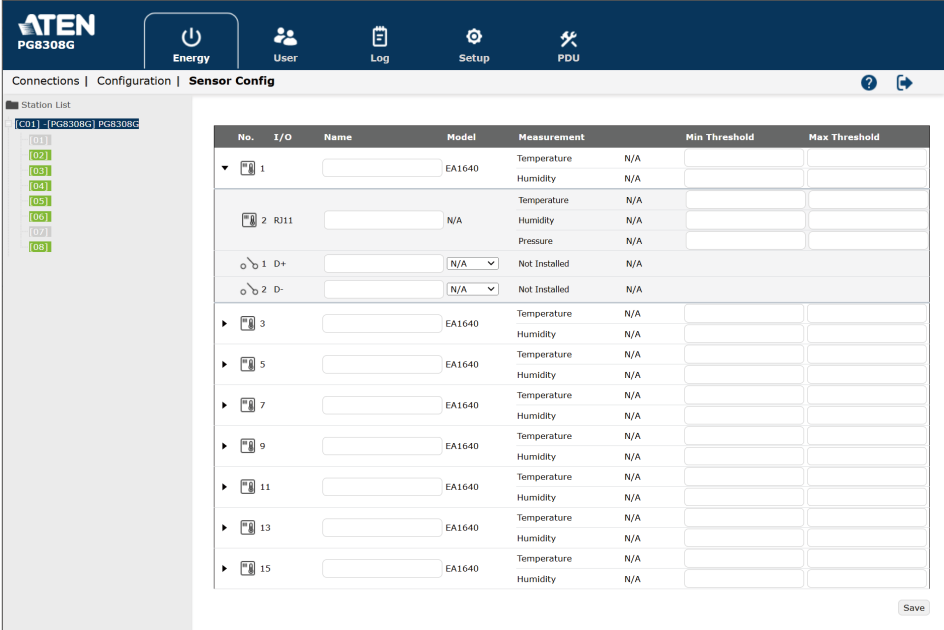

Item	Description
I/O	Shows the port type of the connected EA1640 unit.
Name	Define the name for the connected sensor.
Model	Shows the model name of the connected sensor.
Measurement	Shows the physical phenomena in the environment that this connected sensor detects and monitors.
Threshold	Set the minimum and maximum thresholds that trigger the alarm.

Sensor Installation

You can cascade up to eight EA1640 units when each EA1640 unit is not connected with sensors of other models. If you do install sensors of a different model, note the maximum number of cascade connections, as specified below.

Number of Sensors to be Connected to Each EA1640 via		Maximum Number of EA1640 Sensors
RJ-11 Sensor Port	4-Pin Terminal Block	
0	0	8
0	1	3
1	0	7
1	1	3

- Note:**
1. The maximum transmission distance for eight EA1640 units connected in series is 40 meters.
 2. We use the highest power consumption models, EA1340 (for RJ-11 sensor port) and EA1440 (for 4-pin terminal block), as the connected sensor(s) to estimate the maximum number of EA1640 unit.
 3. The sensors are sold separately. Please contact your ATEN dealer or go to ATEN website for product information.

The diagrams below illustrate the examples about sensor installation.

◆ Connecting One EA1640 Sensor

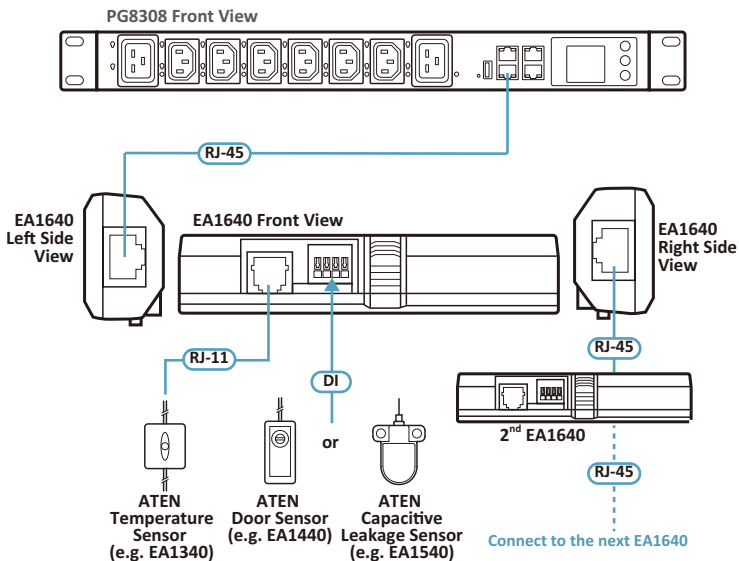

◆ Cascading EA1640 Sensors

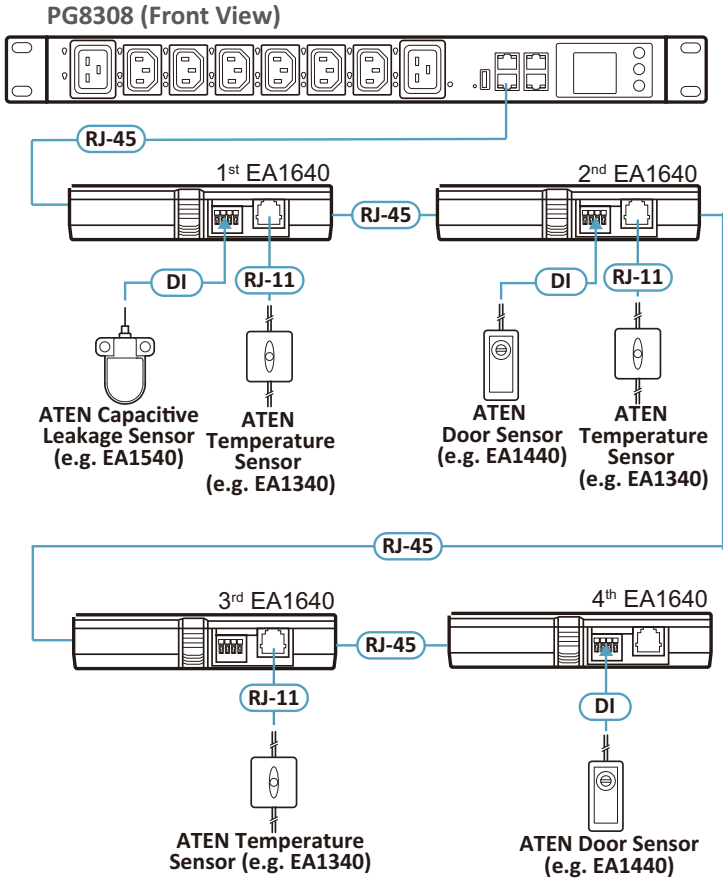

Chapter 6

User Management

Overview

Selecting the *User* tab brings up the *Accounts* menu, with the *Administrator Information* and *User Information* displayed in the main panel.

The screenshot shows the ATEN PG8308G web interface. The top navigation bar includes 'Energy', 'User', 'Log', 'Setup', and 'PDU' tabs. The 'User' tab is selected. The main content area is titled 'Accounts' and contains two sections: 'Administrator information' and 'User information'.

Administrator information

Administrator:

Name: administrator Password:

SNMPv3 account information

Name: administrator Auth-password: Priv-Password:

SNMPv1/v2c community

Read community: administrator Write community: administrator

Telnet

Name: teladmin Password:

SSH

Name: sshadmin Password:

User information

Management	Name	Password	[C01]Outlet									
			All	01	02	03	04	05	06	07	08	
Disable ▾			ⓧ	ⓧ	ⓧ	ⓧ	ⓧ	ⓧ	ⓧ	ⓧ	ⓧ	ⓧ
Disable ▾			ⓧ	ⓧ	ⓧ	ⓧ	ⓧ	ⓧ	ⓧ	ⓧ	ⓧ	ⓧ
Disable ▾			ⓧ	ⓧ	ⓧ	ⓧ	ⓧ	ⓧ	ⓧ	ⓧ	ⓧ	ⓧ
Disable ▾			ⓧ	ⓧ	ⓧ	ⓧ	ⓧ	ⓧ	ⓧ	ⓧ	ⓧ	ⓧ
Disable ▾			ⓧ	ⓧ	ⓧ	ⓧ	ⓧ	ⓧ	ⓧ	ⓧ	ⓧ	ⓧ
Disable ▾			ⓧ	ⓧ	ⓧ	ⓧ	ⓧ	ⓧ	ⓧ	ⓧ	ⓧ	ⓧ
Disable ▾			ⓧ	ⓧ	ⓧ	ⓧ	ⓧ	ⓧ	ⓧ	ⓧ	ⓧ	ⓧ

Note: There is a pre-installed administrator account. It can be used to set up the device and to begin creating users and groups. The username and password for this account is *administrator* and *password*. For security purposes, we strongly recommend changing these to something unique.

Administrator Information

This section is used to set the administrator username and password. Only administrators can view this section. For details, see *Changing the Administrator Login*, page 30.

Administrator information

Administrator:

Name: Password:

SNMPv3 account information

Name: Auth-password: Priv-Password:

SNMPv1/v2c community

Read community: Write community:

Telnet

Name: Password:

SSH

Name: Password:

- ◆ **Administrator**
Define the user name and password for the administrator.
- ◆ **SNMPv3 Account Information**
Enter values for Name, Auth-Password and Priv-Password for SNMPv3 authentication, if required.
- ◆ **SNMPv1/v2c Community**
Enter values Read community and Write community for SNMPv1/V2c authentication, if required.
- ◆ **Telnet**
Use the Name and Password fields to change the account used to login via Telnet sessions.
- ◆ **SSH**
Enter values in the required fields to change the account used to login via SSH.

When you have finished making your configuration settings, click **Save**.

User Information

User information

ManagementName	Password	[C01]Outlet								
		All	01	02	03	04	05	06	07	08
Disable ▾		<input checked="" type="checkbox"/>	<input checked="" type="checkbox"/>	<input checked="" type="checkbox"/>	<input checked="" type="checkbox"/>	<input checked="" type="checkbox"/>	<input checked="" type="checkbox"/>	<input checked="" type="checkbox"/>	<input checked="" type="checkbox"/>	<input checked="" type="checkbox"/>
Disable ▾		<input checked="" type="checkbox"/>	<input checked="" type="checkbox"/>	<input checked="" type="checkbox"/>	<input checked="" type="checkbox"/>	<input checked="" type="checkbox"/>	<input checked="" type="checkbox"/>	<input checked="" type="checkbox"/>	<input checked="" type="checkbox"/>	<input checked="" type="checkbox"/>
Disable ▾		<input checked="" type="checkbox"/>	<input checked="" type="checkbox"/>	<input checked="" type="checkbox"/>	<input checked="" type="checkbox"/>	<input checked="" type="checkbox"/>	<input checked="" type="checkbox"/>	<input checked="" type="checkbox"/>	<input checked="" type="checkbox"/>	<input checked="" type="checkbox"/>
Disable ▾		<input checked="" type="checkbox"/>	<input checked="" type="checkbox"/>	<input checked="" type="checkbox"/>	<input checked="" type="checkbox"/>	<input checked="" type="checkbox"/>	<input checked="" type="checkbox"/>	<input checked="" type="checkbox"/>	<input checked="" type="checkbox"/>	<input checked="" type="checkbox"/>
Disable ▾		<input checked="" type="checkbox"/>	<input checked="" type="checkbox"/>	<input checked="" type="checkbox"/>	<input checked="" type="checkbox"/>	<input checked="" type="checkbox"/>	<input checked="" type="checkbox"/>	<input checked="" type="checkbox"/>	<input checked="" type="checkbox"/>	<input checked="" type="checkbox"/>
Disable ▾		<input checked="" type="checkbox"/>	<input checked="" type="checkbox"/>	<input checked="" type="checkbox"/>	<input checked="" type="checkbox"/>	<input checked="" type="checkbox"/>	<input checked="" type="checkbox"/>	<input checked="" type="checkbox"/>	<input checked="" type="checkbox"/>	<input checked="" type="checkbox"/>
Disable ▾		<input checked="" type="checkbox"/>	<input checked="" type="checkbox"/>	<input checked="" type="checkbox"/>	<input checked="" type="checkbox"/>	<input checked="" type="checkbox"/>	<input checked="" type="checkbox"/>	<input checked="" type="checkbox"/>	<input checked="" type="checkbox"/>	<input checked="" type="checkbox"/>
Disable ▾		<input checked="" type="checkbox"/>	<input checked="" type="checkbox"/>	<input checked="" type="checkbox"/>	<input checked="" type="checkbox"/>	<input checked="" type="checkbox"/>	<input checked="" type="checkbox"/>	<input checked="" type="checkbox"/>	<input checked="" type="checkbox"/>	<input checked="" type="checkbox"/>



To add a user, do the following:

1. Set the Management field to *Enable*.
2. Key in a name and password in the Name and Password fields.
3. Set the outlet-by-outlet permissions of the user in the Outlet field.
4. Click *Save* to save your settings.

Note: Values must be entered in both the Name and Password fields in order to enable an account.

The available options are explained in the following table:

Field	Description
Management	The Management field allows you to enable or disable a user's account: <ul style="list-style-type: none"> ◆ Enable—stores the user account ◆ Disable—disables the user account
Name	From 1 to 16 characters are allowed.
Password	From 1 to 16 characters are allowed.

Field	Description
Outlet	This field allows you to set the outlet-by-outlet permissions of the user. Click on the user/port icon to cycle through the three permissions options, as follows:
	 User has complete access to this outlet.
	 User has read-only access to this outlet.
	 User has no access to this outlet.
Save	Click this button to save your operation or changes

Chapter 7

Log

Overview

The eco PDU keeps a record of all transactions that take place on its installation, and stores up to 1024 events at a any given time.

The screenshot displays the ATEN PG8308G System Log interface. The top navigation bar includes icons for Energy, User, Log (selected), Setup, and PDU. The main content area is titled 'System Log | Notification Settings' and shows a 'Station List' on the left with a selected station 'C01 - PG8308G PG8308G'. The main log table has columns for No., Date/Time, Category, Severity, Station ID, User, and Description. The log entries show various authentication and system events, including session timed out, login failed, and security settings modifications. The interface also includes a 'Refresh' button, 'Event(s) per Page' dropdown, and pagination controls at the bottom.

No.	Date/Time	Category	Severity	Station ID	User	Description
00001	2024-12-08 21:41:08	Authentication	Information	1	administrator	administrator 10.3.52.39 session timed out
00002	2024-12-08 21:38:08	Authentication	Information	1	administrator	administrator 10.3.52.39 logged in
00003	2024-12-08 21:34:22	Authentication	Information	1	administrator	administrator 10.3.52.39 session timed out
00004	2024-12-08 21:31:22	Authentication	Information	1	administrator	administrator 10.3.52.39 logged in
00005	2024-12-08 20:27:57	Authentication	Notification	1	administrator	administrator 10.3.200.63 login failed
00006	2024-12-08 20:27:49	Authentication	Notification	1	administrator	administrator 10.3.200.63 login failed
00007	2024-12-08 20:27:43	Authentication	Notification	1	administrator	administrator 10.3.200.63 login failed
00008	2024-12-08 17:38:18	Authentication	Information	1	administrator	administrator 10.3.66.84 logged in
00009	2024-12-08 17:00:07	Authentication	Information	1	administrator	administrator 10.3.66.84 session timed out
00010	2024-12-08 15:45:47	Authentication	Information	1	administrator	administrator 10.3.66.84 logged in
00011	2024-12-04 23:20:41	Authentication	Information	1	administrator	administrator 10.3.66.84 session timed out
00012	2024-12-04 17:43:42	System	Information	1	administrator	Security settings were modified by administrator
00013	2024-12-04 17:42:50	Authentication	Information	1	administrator	administrator 10.3.66.84 logged in
00014	2024-12-04 17:42:37	Authentication	Information	1	administrator	administrator 10.3.66.84 logged out
00015	2024-12-04 17:42:31	Authentication	Information	1	administrator	administrator 10.3.66.84 logged in
00016	2024-12-04 17:41:02	Authentication	Information	1	administrator	administrator 10.3.66.84 session timed out
00017	2024-12-04 17:39:01	System	Information	1	administrator	Security settings were modified by administrator
00018	2024-12-04 17:37:37	Authentication	Information	1	administrator	administrator 10.3.66.84 logged in

The System Log Event List

The System Log page provides a powerful array of filters and functions that allow you to view and export the log file data, as well as be informed by SNMP Trap / Syslog / SMTP of specified events as they occur.

Refresh Event(s) per Page
Page 1 of 41

No.	Date/Time	Category	Severity	Station ID	User	Description
00001	2024-12-08 21:41:08	Authentication	Information	1	administrator	administrator 10.3.52.39 session timed out
00002	2024-12-08 21:38:08	Authentication	Information	1	administrator	administrator 10.3.52.39 logged in
00003	2024-12-08 21:34:22	Authentication	Information	1	administrator	administrator 10.3.52.39 session timed out
00004	2024-12-08 21:31:22	Authentication	Information	1	administrator	administrator 10.3.52.39 logged in
00005	2024-12-08 20:27:57	Authentication	Notification	1	administrator	administrator 10.3.200.63 login failed
00006	2024-12-08 20:27:49	Authentication	Notification	1	administrator	administrator 10.3.200.63 login failed
00007	2024-12-08 20:27:43	Authentication	Notification	1	administrator	administrator 10.3.200.63 login failed
00008	2024-12-08 17:38:18	Authentication	Information	1	administrator	administrator 10.3.66.84 logged in
00009	2024-12-08 17:00:07	Authentication	Information	1	administrator	administrator 10.3.66.84 session timed out
00010	2024-12-08 15:45:47	Authentication	Information	1	administrator	administrator 10.3.66.84 logged in
00011	2024-12-04 23:20:41	Authentication	Information	1	administrator	administrator 10.3.66.84 session timed out
00012	2024-12-04 17:43:42	System	Information	1	administrator	Security settings were modified by administrator
00013	2024-12-04 17:42:50	Authentication	Information	1	administrator	administrator 10.3.66.84 logged in
00014	2024-12-04 17:42:37	Authentication	Information	1	administrator	administrator 10.3.66.84 logged out
00015	2024-12-04 17:42:31	Authentication	Information	1	administrator	administrator 10.3.66.84 logged in
00016	2024-12-04 17:41:02	Authentication	Information	1	administrator	administrator 10.3.66.84 session timed out
00017	2024-12-04 17:39:01	System	Information	1	administrator	Security settings were modified by administrator

Clear First Page Previous Page Next Page Last Page Save

- ◆ Clicking on a device in the sidebar displays its log events in the main panel's log event list.
- ◆ Clicking the **Refresh** button updates the log list with the latest events.
- ◆ The entry box to the right of the Refresh button lets you set the number of events displayed per page.
- ◆ The top right of the main panel shows the total number of pages in the log file, and the number of the page you are currently viewing.

- ◆ The buttons in the bottom row function as follows:
 - ◆ **Clear:**
Click to erase the contents of the log event list
 - ◆ **First Page:**
Click to go to the first page of the log event list
 - ◆ **Previous Page:**
Click to move to the previous page of the log event list
 - ◆ **Next Page:**
Click to move to the next page of the log event list
 - ◆ **Last Page:**
Click to move to the last page of the log event list
 - ◆ **Save:**
Click to export and save the contents of the log event list as an exported file. Select to save as a .csv file or a .txt file, and click Save again to export it.

Notification Settings

The Notification Settings page is used to specify which of the eco PDU's components will receive notification of a log event. When you click the Notification Settings menu item, a page similar to the one below appears:

Event Log Settings

Event List			
Event	Syslog	E-mail	SNMP
> Enable all system events	<input checked="" type="checkbox"/>	<input checked="" type="checkbox"/>	<input checked="" type="checkbox"/>
∨ Enable all Authentication events	<input checked="" type="checkbox"/>	<input checked="" type="checkbox"/>	<input checked="" type="checkbox"/>
User login	<input checked="" type="checkbox"/>	<input checked="" type="checkbox"/>	<input checked="" type="checkbox"/>
User login failure	<input checked="" type="checkbox"/>	<input checked="" type="checkbox"/>	<input checked="" type="checkbox"/>
User logout	<input checked="" type="checkbox"/>	<input checked="" type="checkbox"/>	<input checked="" type="checkbox"/>
Session timeout	<input checked="" type="checkbox"/>	<input checked="" type="checkbox"/>	<input checked="" type="checkbox"/>
User locked	<input checked="" type="checkbox"/>	<input checked="" type="checkbox"/>	<input checked="" type="checkbox"/>
User unlocked	<input checked="" type="checkbox"/>	<input checked="" type="checkbox"/>	<input checked="" type="checkbox"/>
> Enable all User Management events	<input checked="" type="checkbox"/>	<input checked="" type="checkbox"/>	<input checked="" type="checkbox"/>
> Enable all Device Management events	<input checked="" type="checkbox"/>	<input checked="" type="checkbox"/>	<input checked="" type="checkbox"/>

Save

- ◆ The event categories are listed in the left column.

- ◆ When you first open the page, only the main category items appear. (Main category item rows have a gray background.)
- ◆ Subcategory items are nested under the main category headings. Click the accordion in front of the main category headings to display the subcategory items. (Subcategory item rows have a white background.)
- ◆ Click the checkboxes under the column headings to select which component(s) will receive notification of the log events.
 - ◆ Clicking on a main category heading's row automatically selects all the subcategory items nested below it.
 - ◆ If you only want to set notification for some of the subcategory events, don't put a check in the main category row. Instead, drop down the subcategory list, and only check the subcategory events you want.
- ◆ When you have finished making your setting choices, click Save. When a specified log event occurs, notification of that event will be sent to the selected component.

When you have finished making your configuration settings, click **Save**.

Chapter 8 Setup

Device Management

The *Setup* page allows administrators and users with device management permission to configure and control the overall eco PDU operations.

The screenshot displays the ATEN PG8308G Setup interface. The top navigation bar includes icons for Energy, User, Log, Setup (active), and PDU. Below the navigation bar, the breadcrumb trail reads: Device Configuration | Security | Wireless Network | Cascade | Rules | Scheduler | Python Script. The main content area is titled 'Station List' and shows a list of stations with IDs [01] through [08]. The selected station is [01] - [PG8308G] PG8308G. The configuration page is divided into several sections:

- General:** PDU Name: PG8308G; MAC Address: 00:10:74:25:DD:22; MAC Address: 00:10:74:25:DD:23; Firmware Version: 1.0.092; Rack Location name: (empty field).
- Service Ports:** Radio buttons for 'Only HTTPs' (selected) and 'HTTP / HTTPs'. Input fields for HTTP: 80 and HTTPS: 443.
- Serial Settings:** Console Mode: RS232; RS485Serial Port Address: 01.
- IPv4 Configuration:** Checkboxes for 'Enable bridge' (unchecked) and 'Obtain IP address automatically [DHCP]' (selected).

© Copyright: 2022 ATEN @ International Co., Ltd.

Device Configuration

This page presents information about the device selected, as described in the following sections:

General

General

PDU Name:

MAC Address: 00:10:74:25:DD:22

MAC Address: 00:10:74:25:DD:23

Firmware Version: 1.0.092

Rack Location name:

Item	Meaning
PDU Name	This field lets you rename the device as desired. Simply key in the name of your choice. Click Save (located at the bottom of the page) to save the new name.
MAC Address	This item displays the eco PDU's MAC address.
Firmware Version	This item displays the current firmware version. You can check if there are any newer versions available on the ATEN website.
Rack Location Name	This field lets you give the rack location a unique name for easy reference.

Service Ports

As a security measure, if a firewall is being used, the administrator can specify the port numbers that the firewall will allow. If a port other than the default is used, users must specify the port number as part of the IP address when logging in. If an invalid port number (or no port number) is specified, the eco PDU will not be found.

Select whether to allow only secure browser logins, as shown below:

Service Ports

Only HTTPS HTTP / HTTPS

HTTP:

HTTPS:

An explanation of the fields is given in the table below:

Field	Explanation
HTTP	The port number for a browser login. The default is 80.
HTTPS	The port number for a secure browser login. The default is 443.

Note: 1. Valid entries for all of the service ports are from 1 to 65535.

2. The service ports cannot have the same value. You must set a different value for each.
3. If there is no firewall (on an Intranet, for example), it doesn't matter what these numbers are set to, since they have no effect.

Serial Settings

In this field, you can configure the console mode and RS-485 serial port address for remote control from the hardware and software controller.

Serial Settings

Console Mode ▼

RS485Serial Port Address: ▼

IPv4 Configuration

The eco PDU's IPv4 IP and DNS addresses (the traditional method of specifying IP addresses) can either be assigned automatically (DHCP), or manually, by specifying a fix IP address.

IPv4 Configuration

Enable bridge

Ethernet1

Obtain IP address automatically [DHCP]

Set IP address manually [Fixed IP]

IP Address:

Subnet Mask:

Default Gateway:

Obtain DNS server address automatically

Set DNS server address manually

Preferred DNS Server:

Alternate DNS Server:

Ethernet2

Obtain IP address automatically [DHCP]

Set IP address manually [Fixed IP]

IP Address:

Subnet Mask:

Default Gateway:

Obtain DNS server address automatically

Set DNS server address manually

Preferred DNS Server:

Alternate DNS Server:

Enable DHCP server

IP Pool Starting Address:

IP Pool Ending Address:

◆ For dynamic IP address assignment, select the *Obtain IP address automatically* radio button. (This is the default setting.)

◆ To specify a fixed IP address, select the *Set IP address manually* radio button and fill in the IP address with values appropriate for your network.

◆ For automatic DNS Server address assignment, select the *Obtain DNS Server address automatically* radio button.

◆ To specify the DNS Server address manually, select the *Set DNS server address manually* radio button, and fill in the addresses for the Preferred and Alternate DNS servers with values appropriate for your network.

Note: 1. If you choose *Obtain IP address automatically*, when the device starts up, it shall wait for its assigned IP address from the DHCP server. If it hasn't obtained an IP address after one minute, it automatically reverts to its default IP address (192.168.0.60.)

2. If the device is on a network that uses DHCP to assign network addresses, and you need to ascertain its IP address, see *IP Address Determination*, page 129.
3. Specifying the Alternate DNS Server address is optional.

IPv6 Configuration

The eco PDU's IPv6 IP and DNS addresses (the traditional method of specifying IP addresses) can either be assigned automatically (DHCP), or manually, by specifying a fix IP address.

IPv6 Configuration

Ethernet1

Enable autoconfiguration

Set configuration manually

IP Address:

Static Prefix Length:

Default Gateway:

Use DHCPv6 to obtain DNS Server Addresses

Set DNS server address manually

Preferred DNS Server:

Alternate DNS Server:

Ethernet2

Enable autoconfiguration

Set configuration manually

IP Address:

Static Prefix Length:

Default Gateway:

Use DHCPv6 to obtain DNS Server Addresses

Set DNS server address manually

Preferred DNS Server:

Alternate DNS Server:

- ◆ For dynamic IP address assignment, select the *Enable autoconfiguration* radio button. (This is the default setting.)

- ◆ To specify a fixed IP address, select the *Set configuration manually* radio button and fill in the IP address with values appropriate for your network.
- ◆ For automatic DNS Server address assignment, select the *Use DHCPv6 to obtain DNS Server Addresses* radio button.
- ◆ To specify the DNS Server address manually, select the *Set DNS server address manually* radio button, and fill in the addresses for the Preferred and Alternate DNS servers with values appropriate for your network.

-
- Note:**
1. If you choose *Obtain IP address automatically*, when the device starts up, it shall wait for its assigned IP address from the DHCP server. If it hasn't obtained an IP address after one minute, it automatically reverts to its default IP address (192.168.0.60.)
 2. If the device is on a network that uses DHCP to assign network addresses, and you need to ascertain its IP address, see *IP Address Determination*, page 129.
 3. Specifying the Alternate DNS Server address is optional.
-

Event Notification

The Event Notification section is divided into three sections: SMTP Settings, SNMP Trap Receivers, and Syslog Server. Each section is described below.

Note: SMTP communications are supported on Port 25.

SMTP Server

Event Notification

SMTP Server

Enable report from the following SMTP Server

SMTP Server:

SMTP Port Number:

Server requires authentication

Account Name:

Password:

Enable secure connection (STARTTLS)

From:

To:

To have the eco PDU device send e-mail reports from the SMTP server, do the following:

1. Check *Enable report from the following SMTP server*, and key in the IP address of your SMTP server.
2. If your server requires authentication, check the *My server requires authentication* checkbox.
3. Key in the appropriate account information in the *Account Name*, *Password*, and *From* fields.

Note: Only one email address is allowed in the *From* field, and it cannot exceed 64 characters.)

4. (Optional) To enable TLS encryption on your notifications, check the *Enable secure connection (STARTTLS)* checkbox. We support TLS1.0, TLS1.1, and TLS1.2.
5. Key in the e-mail address(es) of where you want the event reports to be sent in the *To* field.

Note: If you are sending the report to more than one e-mail address, separate the addresses with a semicolon or comma, depending on the specified mail server. The total cannot exceed 256 characters.

SNMP Trap Receivers

Up to four SNMP management stations can be specified. If you want to send out SNMP trap notifications, do the following:

SNMP Trap Receiver

Enable SNMP Trap SNMPv3 SNMPv2c SNMPv1

Receiver IP 1:

Service Port 1:

Community 1:

User name 1:

Auth-password 1:

Priv-Password 1:

Receiver IP 2:

Service Port 2:

Community 2:

User name 2:

Auth-password 2:

Priv-Password 2:

1. Check *Enable SNMP Trap*.
2. Select which version of SNMP you want to use.
3. Key in the IP address(es) and the service port number(s) of the computer(s) to be notified by the SNMP trap events. The valid port range is 1–65535, with the default port value being 162.

Note: Make sure that the port number you specify here matches the port number used by the SNMP receiver computer.

4. Key in the community value(s) if required by the version of SNMP (SNMPv1 and SNMPv2c) used.
5. Key in the auth/privacy password(s) that correspond to each of the stations by the version of SMP (SNMPv3) used.

Syslog Server

To record all events that take place on the eco PDU devices, and write them to the eco PDU Syslog server, do the following:

Syslog Server
 Enable Syslog Server
Server IP:
Service Port:

1. Check **Enable Syslog Server**.
2. Key in the IP address and port number of the Syslog server. The valid port range is 1–65535. The default port value is 514.

Date/Time

Set the parameters according to the information described below.

Date Time

Time Zone

 Daylight Savings Time

Time Zone

- ◆ To establish the time zone that the eco PDU is located in, use the *Time Zone* drop-down menu to choose the city that most closely corresponds to where it is at.
- ◆ If your country or region employs daylight saving time (summer time), check the corresponding checkbox.

Manual Input

Manually Input

Date: (YYYY-MM-DD) 

Time: (HH:MM:SS)

Sync with PC

Use this section to specify the eco PDU's date and time manually.

- ◆ Click the calendar icon and select a calendar entry for the date.
- ◆ Key the time into the *Time* field, using the HH:MM:SS (hours, minutes, seconds) format.

Note: This section is only enabled when *auto adjustment* (in the *Network Time* section) is disabled (unchecked).

As an alternative to specifying the date and time by entering them into the date and time fields, you can check the *Sync with PC* checkbox, where the eco PDU will take its date and time settings from the locally connected PC.

Network Time

To have the time automatically synchronized to a network time server, do the following:

Network Time

Enable auto adjustment

AU | ntp1.cs.mu.OZ.AU ▼

Preferred custom server IP:

Alternate time server:

AU | ntp1.cs.mu.OZ.AU ▼

Alternate custom server IP:

Adjust time every days

1. Check the *Enable auto adjustment* checkbox.

2. Select your preferred time server

– or –

Check the *Preferred custom server IP* checkbox, and key in the IP address of the time server of your choice.

3. If you want to configure an alternate time server, check the *Alternate time server* checkbox, and repeat step 2 for the alternate time server entries.
4. Key in your choice for the number of days between synchronization procedures.

Finishing Up

When you have finished making your settings on this page, click **Save**.

After you have saved your changes, click **Adjust Time Now** to synchronize immediately according to the time settings.

Security

The Security page controls access to the eco PDU.

The screenshot shows the ATEN PG8308G PDU web interface. The top navigation bar includes 'Energy', 'User', 'Log', 'Setup', and 'PDU'. The main content area is titled 'Security' and contains the following sections:

- Login Failures:** 'Allowed: 3' and 'Timeout: 30 min'.
- Working Mode:**
 - Enable Telnet Server
 - Enable Modbus
 - Enable SSH
- TLS Support:**
 - Enable TLS1.0/TLS1.1
- IPInstaller Setting:**
 - Disable
 - Read-only
 - Read-write
- Session Timeout:**
 - Enable Web Session Timeout in 2 Minute(s)
- Account Policy:**
 - Minimum Username Length: 6
 - Minimum Password Length: 6

© Copyright 2022 ATEN® International Co., Ltd.

Login Failures

Login Failures allows you to set your account lockout policy.

Login Failures

Allowed:

Timeout: min

For *Allowed* field, enter the number of failed login attempts that will cause a user account to be locked. For *Timeout* field, enter the account lockout duration.

Working Mode

Working Mode

Enable Telnet Server

Enable Modbus

Enable SSH

- ◆ If Enable Telnet Server is checked, the eco PDU is accessible via a Telnet sessions using the Telnet username and password (see Telnet, page 25).
- ◆ If Enable Modbus is checked, the eco PDU is accessible and the measurements of the eco PDU such as current, voltage, power, temperature, humidity, and pressure can be read via the Modbus communications protocol.
- ◆ If Enable SSH is checked, the PDU is accessible and the measurements of the PDU such as current, voltage, power, temperature, humidity, and pressure can be read via the SSH cryptographic network protocol.

TLS Support

TLS Support

Enable TLS1.0/TLS1.1

If TLS Support is checked, the PDU is accessible on older computers or older web browsers that support TLS1.0 or TLS1.1 data encryption.

IPInstaller Setting

IPInstaller Setting

Disable Read-only Read-write

- ◆ If Disable is checked, the IP address of the eco PDU cannot be found by the IP Installer software.
- ◆ If Readonly is checked, the IP address of the eco PDU can be found but not configurable by the IP Installer software.
- ◆ If Read-write is checked, the IP address of the eco PDU can be found and configurable by the IP Installer software.

Session Timeout

Session Timeout

Enable Web Session Timeout in Minute(s)

If *Enable Web Session Timeout* is checked, a user's web session will logout due to inactivity after the number of Minute(s) entered (1–5) is surpassed.

Account Policy

The Account Policy section governs policies in regard to the login usernames and passwords.

Account Policy

Minimum Username Length:

Minimum Password Length:

Password Must Contain at Least:

- One Upper Case
- One Lower Case
- One Number

Disable Duplicate Login

Check a policy and enter the required information in the appropriate fields.

Item	Description
Minimum Username Length	Sets the minimum number of characters required for a username. Acceptable values are from 1 to 16.
Minimum Password Length	Sets the minimum number of characters required for a password. Acceptable values are from 1 to 16.
Password Must Contain At Least	Checking any of these items requires users to include at least one of the specified items in their password. Note: This policy does not affect existing user accounts. Only new user accounts created after this policy has been enabled, and users required to change their passwords are affected.
Disable Duplicate Login	Check this to prevent users from logging in with the same account at the same time.

IP Filter / MAC Filter

If any filters have been configured, they appear in the IP Filter and/or MAC Filter list boxes.

IP and MAC Filters control access to the eco PDU based on the IP and/or MAC addresses of the client computers attempting to connect. A maximum of 5 IP filters and 5 MAC filters are allowed.

To enable IP and/or MAC filtering, check the *IP Filter Enable* and/or *MAC Filter Enable* checkbox.

- ◆ If the include button is checked, all addresses within the filter range are allowed access, while all other addresses are denied access.
- ◆ If the exclude button is checked, all addresses within the filter range are denied access, while all other addresses are allowed access.

Adding Filters

- ◆ To add an IP filter, do the following:
 1. Click **Add**. A dialog box similar to the one below appears:

2. Specify the start filter address in the dialog box (for example, 192.168.0.200), then click **OK**.

3. To filter a single IP address, key in the same address as the start IP. To filter a continuous range of addresses, key in the end number of the range (for example, 192.168.0.225).
 4. After filling in the address, click **OK**.
 5. Repeat these steps for any additional IP address ranges you want to filter.
- ◆ To add a MAC filter, do the following:
 1. Click **Add**. A dialog box similar to the one below appears:

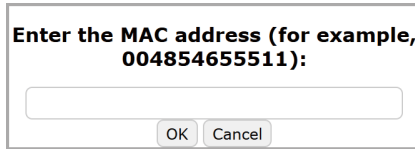

2. Specify the MAC address in the dialog box (for example, 001074670000), then click **OK**.
3. Repeat these steps for any additional MAC addresses you want to filter.

IP Filter / MAC Filter Conflict

If there is a conflict between an IP and MAC filter—for example, where a computer’s IP address is allowed by the IP filter but its MAC address is excluded by the MAC filter—then that computer’s access is blocked. In other words, if either filter blocks a computer, then the computer is blocked, no matter what the other filter is set to.

Modifying Filters

To modify a filter, select it in the IP Filter or MAC Filter list box and click **Modify**. The Modify dialog box is similar to the Add dialog box. When it comes up, simply delete the old address(es) and replace it with the new one(s).

Deleting Filters

To delete a filter, select it in the IP Filter or MAC Filter list box and click **Delete**.

Authentication & Authorization

The Authentication & Authorization field is used to set up login authentication and authorization management from external sources.

Authentication & Authorization

Auth Type:

RADIUS Settings

To allow authentication and authorization for the eco PDU device through a RADIUS server, do the following:

Authentication & Authorization

Auth Type:

RADIUS Settings

Preferred RADIUS Server IP:

Preferred RADIUS Service Port:

Alternate RADIUS Server IP:

Alternate RADIUS Server Port:

Timeout: sec

Retries:

Shared Secret (at least 6 characters):

1. Use the drop-down menu and select **RADIUS**.
2. Fill in the IP addresses and service port numbers for the Preferred and Alternate RADIUS servers. The default port number for the Preferred server is 1812; the default port number for the Alternate server is 1645.

Note: Make sure that the port numbers you specify here match the port numbers used by the RADIUS servers.

3. In the *Timeout* field, set the time in seconds that the eco PDU device shall wait for the RADIUS server to reply before it times out. The default timeout is 3 seconds.

4. In the *Retries* field, set the number of allowed retries for attempting to connect to the RADIUS server. The default retries is 3 times.
5. In the *Shared Secret* field, key in the character string that you want to use for authentication between the eco PDU device and the RADIUS Server.
6. On the RADIUS server, set the entry for each user as follows:

su/xxxx

Where *xxxx* represents the username given to the user when the account was created on the eco PDU device. The user's access rights equivalent to the ones assigned for the eco PDU device. (See *Device Management*, page 57.)

Note: su/user supports view ports only; su/administrator supports all eco PDU functions.

LDAP Settings

To allow authentication and authorization for the eco PDU device through a LDAP server, do the following:

Authentication & Authorization

Auth Type:

LDAP Settings

Type of LDAP Server:

Security:

IP address/hostname:

Port:

Bind DN:

Password:

Login Name Attribute:

Base DN:

User entry object class:

Login Attribute:

Timeout: sec

1. Use the drop-down menu and select **LDAP**.

2. Select a Type of LDAP Server and Security option and fill in the IP addresses/hostname, port numbers, Bind DN, Password, Login Name Attribute, Base DN, User entry object class, and Login Attribute for the LDAP servers. The default port number is 389.

Note: Make sure that the port numbers you specify here match the port numbers used by the LDAP servers.

3. In the *Timeout* field, set the time in seconds that the eco PDU device shall wait for the LDAP server to reply before it times out. The default timeout is 3 seconds.
4. On the LDAP server, set the entry for each user as follows:

su/xxxx

Where *xxxx* represents the username given to the user when the account was created on the eco PDU device. The user's access rights equivalent to the ones assigned for the eco PDU device. (See *Device Management*, page 57.)

Note: su/user supports view ports only; su/administrator supports all eco PDU functions.

TACACS+ Settings

To allow authentication and authorization for the eco PDU device through a TACACS+ server, do the following:

Authentication & Authorization

Auth Type: ▼

TACACS PLUS Settings

Preferred TACACS PLUS Server IP:

Preferred TACACS PLUS Service Port:

Alternate TACACS PLUS Server IP:

Alternate TACACS PLUS Server Port:

Timeout: sec

Retries:

Shared Secret (at least 6 characters):

1. Use the drop-down menu and select **TACACS+**.
2. Fill in the IP addresses and service port numbers for the Preferred and Alternate TACACS+ servers. The default port number for the Preferred server is 49; the default port number for the Alternate server is 49.

Note: Make sure that the port numbers you specify here match the port numbers used by the TACACS+ servers.

3. In the *Timeout* field, set the time in seconds that the eco PDU device shall wait for the TACACS+ server to reply before it times out. The default timeout is 3 seconds.
4. In the *Retries* field, set the number of allowed retries for attempting to connect to the TACACS+ server. The default retries is 3 times.
5. In the *Shared Secret* field, key in the character string that you want to use for authentication between the eco PDU device and the TACACS+ Server.
6. On the TACACS+ server, set the entry for each user as follows:

`su/xxxx`

Where `xxxx` represents the username given to the user when the account was created on the eco PDU device. The user's access rights equivalent to the ones assigned for the eco PDU device. (See *Device Management*, page 57.)

Note: `su/user` supports view ports only; `su/administrator` supports all eco PDU functions.

Private Certificate

When logging in over a secure (SSL) connection, a signed certificate is used to verify that the user is logging in to the intended site. For enhanced security, the *Private Certificate* section allows you to use your own private encryption key and signed certificate, rather than the default ATEN certificate.

Private Certificate

Private Key:

Certificate:

There are two methods for establishing your private certificate: generating a self-signed certificate or importing a third-party certificate authority (CA) signed certificate.

Generating a Self-Signed Certificate

If you wish to create your own self-signed certificate, a free utility—`openssl.exe`—is available for download over the web.

Obtaining a CA Signed SSL Server Certificate

For better ensured security, we recommend using a third-party certificate authority (CA) signed certificate. To obtain a third-party signed certificate, go to a CA (Certificate Authority) website to apply for an SSL certificate. After the CA sends you the certificate and private encryption key, save them to a convenient location on your computer.

Importing the Private Certificate

To import the private certificate, do the following:

1. Click **Browse** to the right of *Private Key* to locate the location path of the private encryption key file, and select it.
2. Click **Browse** to the right of *Certificate* to locate the location path of the certificate file, and select it.
3. Click **Upload** to complete the procedure.

Note: 1. Clicking **Restore Default** returns the device to using the default ATEN certificate.

2. Both the private encryption key and the signed certificate must be imported at the same time.
-

When you have finished making your settings on this page, click **Save**.

Wireless Network

The Wireless Network page allows you to enable the Wi-Fi capability of the eco PDU.

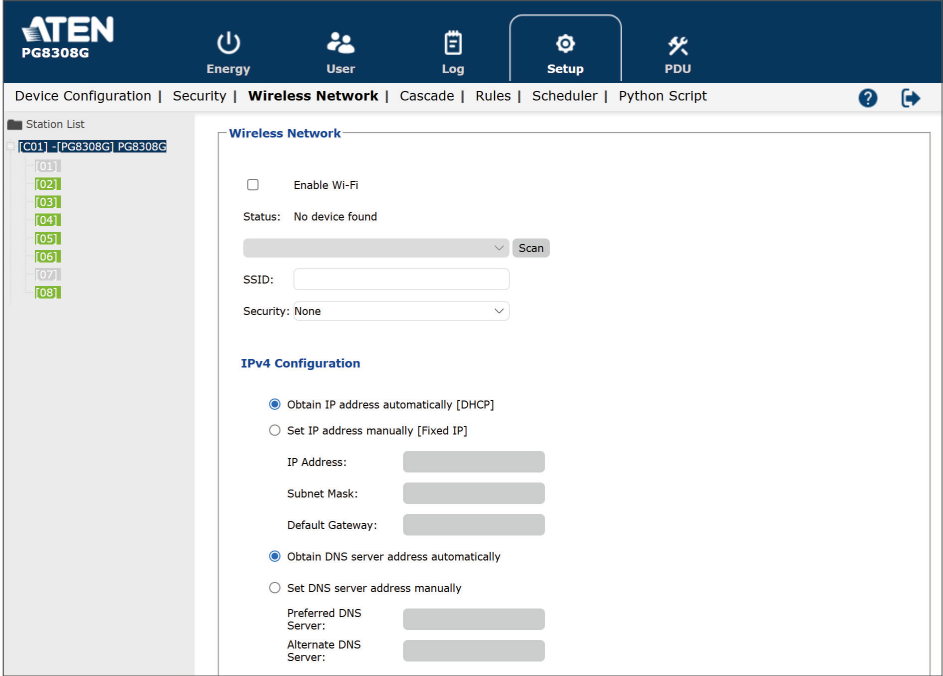

Item	Description
Enable Wi-Fi	Check to enable the Wi-Fi function on the eco PDU.
Scan	Once the Wi-Fi adapter is connected to the eco PDU's USB Type-A port, click Scan to scan for any available wireless network in your area.
SSID	Manually key in the SSID of the wireless network you want to connect to.
Security	Use the drop-down menu to select a security type for your wireless network, and manually key in the password.

IPv4 Configuration

The eco PDU's IPv4 IP and DNS addresses (the traditional method of specifying IP addresses) can either be assigned automatically (DHCP), or manually, by specifying a fix IP address.

IPv4 Configuration

Obtain IP address automatically [DHCP]

Set IP address manually [Fixed IP]

IP Address:

Subnet Mask:

Default Gateway:

Obtain DNS server address automatically

Set DNS server address manually

Preferred DNS Server:

Alternate DNS Server:

- ◆ For dynamic IP address assignment, select the *Obtain IP address automatically* radio button. (This is the default setting.)
- ◆ To specify a fixed IP address, select the *Set IP address manually* radio button and fill in the IP address with values appropriate for your network.
- ◆ For automatic DNS Server address assignment, select the *Obtain DNS Server address automatically* radio button.
- ◆ To specify the DNS Server address manually, select the *Set DNS server address manually* radio button, and fill in the addresses for the Preferred and Alternate DNS servers with values appropriate for your network.

Note: 1. If you choose *Obtain IP address automatically*, when the device starts up, it shall wait for its assigned IP address from the DHCP server. If it hasn't obtained an IP address after one minute, it automatically reverts to its default IP address (192.168.0.60.)

2. If the device is on a network that uses DHCP to assign network addresses, and you need to ascertain its IP address, see *IP Address Determination*, page 129.

3. Specifying the Alternate DNS Server address is optional.

IPv6 Configuration

The eco PDU's IPv6 IP and DNS addresses (the traditional method of specifying IP addresses) can either be assigned automatically (DHCP), or manually, by specifying a fix IP address.

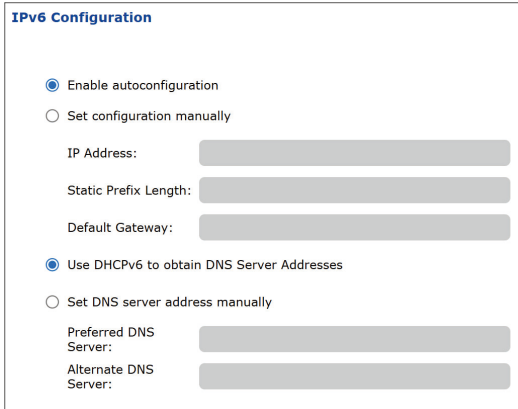

The screenshot shows a web form titled "IPv6 Configuration". It contains two radio button options: "Enable autoconfiguration" (selected) and "Set configuration manually". Below these are three input fields: "IP Address:", "Static Prefix Length:", and "Default Gateway:". There are two more radio button options: "Use DHCPv6 to obtain DNS Server Addresses" (selected) and "Set DNS server address manually". Below these are two input fields: "Preferred DNS Server:" and "Alternate DNS Server:".

- ◆ For dynamic IP address assignment, select the *Enable autoconfiguration* radio button. (This is the default setting.)
- ◆ To specify a fixed IP address, select the *Set configuration manually* radio button and fill in the IP address with values appropriate for your network.
- ◆ For automatic DNS Server address assignment, select the *Use DHCPv6 to obtain DNS Server Addresses* radio button.
- ◆ To specify the DNS Server address manually, select the *Set DNS server address manually* radio button, and fill in the addresses for the Preferred and Alternate DNS servers with values appropriate for your network.

-
- Note:**
1. If you choose *Obtain IP address automatically*, when the device starts up, it shall wait for its assigned IP address from the DHCP server. If it hasn't obtained an IP address after one minute, it automatically reverts to its default IP address (192.168.0.60).
 2. If the device is on a network that uses DHCP to assign network addresses, and you need to ascertain its IP address, see *IP Address Determination*, page 129.
 3. Specifying the Alternate DNS Server address is optional.
-

Cascade

The Cascade page allows you to manage and cascade eco PDU in your installation. Check *Manage other PDUs over Ethernet* checkbox to start the settings.

Cascade

Manage other PDUs over Ethernet ¹

Add Device Remove Connect Discover Interface LAN1 Protocol: IPv4

ID	State	Model	Name	IP	MAC	Status
-	Standalone	PG8308G	PG8308G	-	-	-

Save

Adding a PDU

To add a cascade PDU, do the following:

1. Click **Add Device**. A dialog box similar to the one below appears:

Add PDU Test Connection

ID: 02

IP:

Username:

Password:

Add Cancel

2. Specify the ID, IP address, username, and password in the dialog box, then click **Add**.
3. (Optional) You may test the connection between to cascade eco PDU before you click Add.

Deleting a PDU

To delete a cascaded PDU, do the following:

1. Check the checkbox(s) beside the ID column of the eco PDU(s) you want to remove.
2. Click **Remove**.

Connecting a PDU

To connect to a cascaded PDU, do the following:

1. Check the checkbox(s) beside the ID column of the eco PDU(s) you want to connect.
2. Click **Connect**.

Discovering

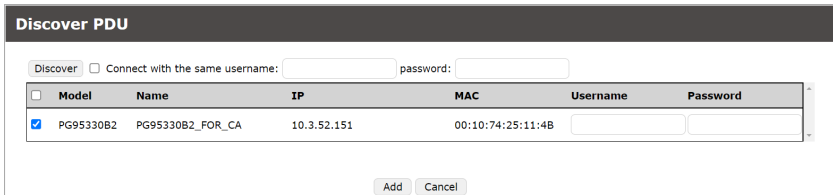

Discover Connect with the same username: password:

<input type="checkbox"/>	Model	Name	IP	MAC	Username	Password
<input checked="" type="checkbox"/>	PG95330B2	PG95330B2_FOR_CA	10.3.52.151	00:10:74:25:11:4B	<input type="text"/>	<input type="text"/>

To discover a cascaded PDU in your installation, do the following:

1. Check the checkbox beside discover and key in the username and password information.
2. Click **Discover**.

Rules

The Rules page allows you to manage and set rules for the eco PDU in your installation.

Add a New Rule

To add a new rule, do the following:

The image shows three sequential screenshots of the 'Rules' page interface, illustrating the steps to add a new rule:

- Step 1:** The 'Rules' page shows an 'Add' button highlighted with a red circle and the number 1. An arrow points down to the next screenshot.
- Step 2:** The 'Rule1' rule is expanded. A 'Detail' button (represented by a right-pointing chevron) is highlighted with a red circle and the number 2. An arrow points down to the next screenshot.
- Step 3:** The expanded rule configuration is shown. It includes a table for 'Station' and 'Event', and a table for 'Sequence'. Two 'Add' buttons are highlighted with red circles and the numbers 2a and 2b respectively. An arrow points down to the final screenshot.
- Step 4:** The final configuration is shown. A 'Save' button is highlighted with a red circle and the number 3. A red circle with the number 4 highlights the 'Add' button at the bottom left of the configuration area.

1. Click on the *Add* button to continue.
2. Click the Detail button to expand the fields to specify the rule.
 - a) To add more station, click *Add*.
 - b) To add more sequence, click *Add*.
3. Click on the Save button to finish.
4. To add more rules, repeat the aforementioned steps.

Edit the Rules

You can edit the rules using the elements:

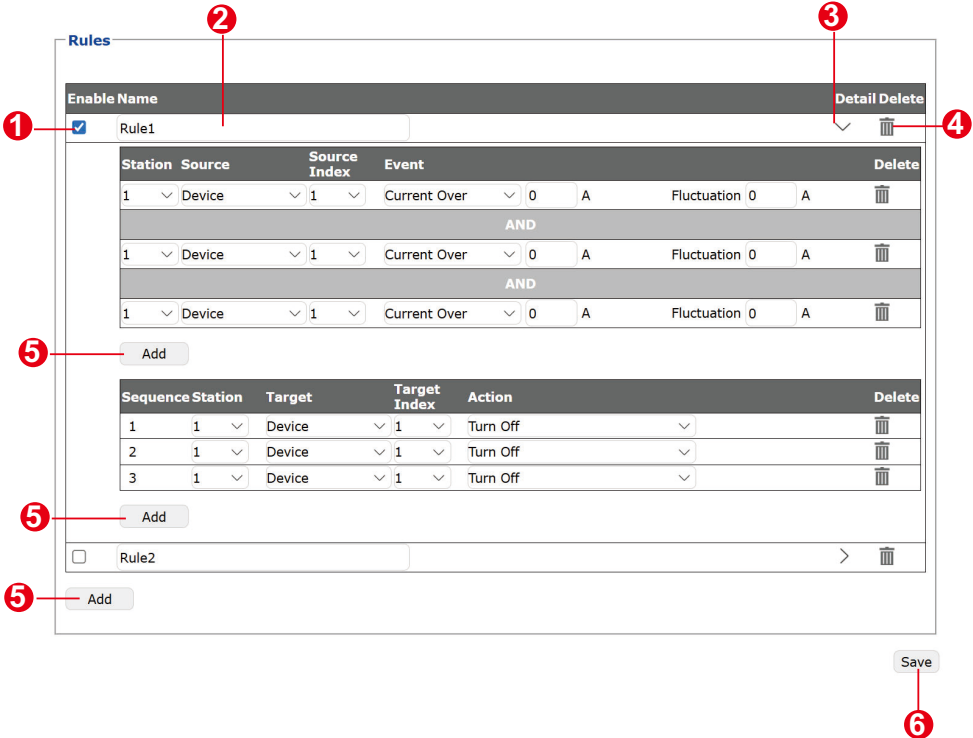

No.	Item	Description
1	Enable	Check to enable the rule you configured for your eco PDU.
2	Name	Enter the name for the rules.
3	Detail	Click to bring up more options to configure the rules.
4	Delete	Click the bin icon to remove the rules.
5	Add	Click to add more Station Source, Sequence Station, or Rules.
6	Save	Click to save the changes you just made.

Scheduler

Use the *Scheduler* page to power on, power off, or reboot the eco PDU.

The screenshot shows the ATEN PG8308G Scheduler interface. The top navigation bar includes 'Energy', 'User', 'Log', 'Setup' (selected), and 'PDU'. The breadcrumb trail is 'Device Configuration | Security | Wireless Network | Cascade | Rules | Scheduler | Python Script'. On the left, a 'Station List' shows 'C01 - PG8308G' selected. The main area is titled 'Scheduler' and contains two sections: 'Events' and 'Actions'. Both sections have a '+ Create Event' and '+ Create Action' button respectively. The 'Events' table has columns 'Event Name', 'Frequency', and 'Actions', and currently displays 'No Scheduler Event'. The 'Actions' table has columns 'Action Name', 'Operation Time', and 'Action', and currently displays 'No Scheduler Action'. A copyright notice '© Copyright 2022 ATEN © International Co., Ltd.' is at the bottom.

Creating an Event

To create an event, do the following:

1. Go to *Setup > Scheduler*.
2. Create one or more power-on, power-off, and/or reboot actions. These actions will be selectable when configuring an event.
 - a) Click +Create Action.

The screenshot shows the 'Actions' table in the Scheduler interface. The table has three columns: 'Action Name', 'Operation Time', and 'Action'. One action is listed: 'Working days power on' with 'Immediately' operation time and 'Power ON outlet 01,02,03' action. A '+ Create Action' button is highlighted with a red dashed box.

Action Name	Operation Time	Action
Working days power on	Immediately	Power ON outlet 01,02,03

- b) In the pop-up screen, name the action, and use the drop-down lists to configure the action and the target outlet(s).

← Create Action

Action Name

Action 

outlets

- c) Click Save. The action is added to the list.

Actions			+ Create Action
Action Name	Operation Time	Action	
Working days power on	Immediately	Power ON outlet 01,02,03	
Working day power off	Immediately	Power OFF outlet 01,02,03	

3. Create an event.

- a) Click +Create Event.
- b) In *Create Event* page, name the event, and then configure the schedule and action as needed.

← Create Event

Event Name

Scheduled Time  :

Actions

Action Name	Operation Time	Action

- c) Click Save. The event is added to the event list. Use the toggle button to enable/disable created events.

Scheduler

Events + Create Event

Event Name	Frequency	08:00	Mon,Tue,Wed,Thu,Fri	Actions	
Daily Power On	Weekly	08:00	Mon,Tue,Wed,Thu,Fri	Working days power on	<input checked="" type="checkbox"/>
Working days power off	Weekly	19:00	Mon,Tue,Wed,Thu,Fri	Working day power off	<input checked="" type="checkbox"/>

Actions + Create Action

Action Name	Operation Time	Action
Working days power on	Immediately	Power ON outlet 01,02,03
Working day power off	Immediately	Power OFF outlet 01,02,03

Python Script

Python Script allows users to read the status of ports / connected sensors and control the outlets using the python script integrated with ATEN Python library.

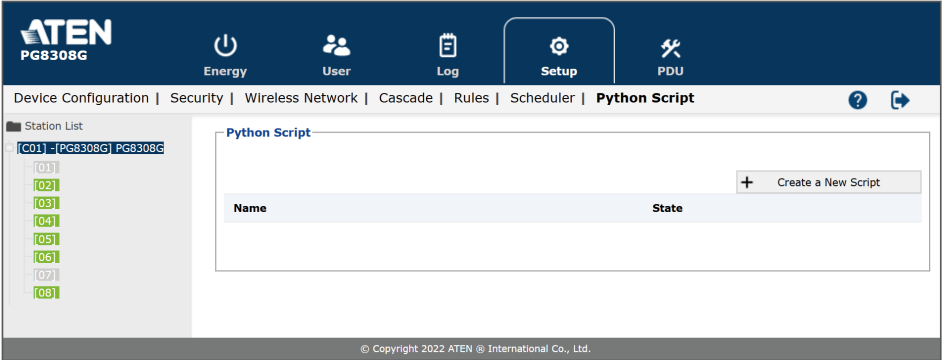

Add a New Script

To add a new script, do the following:

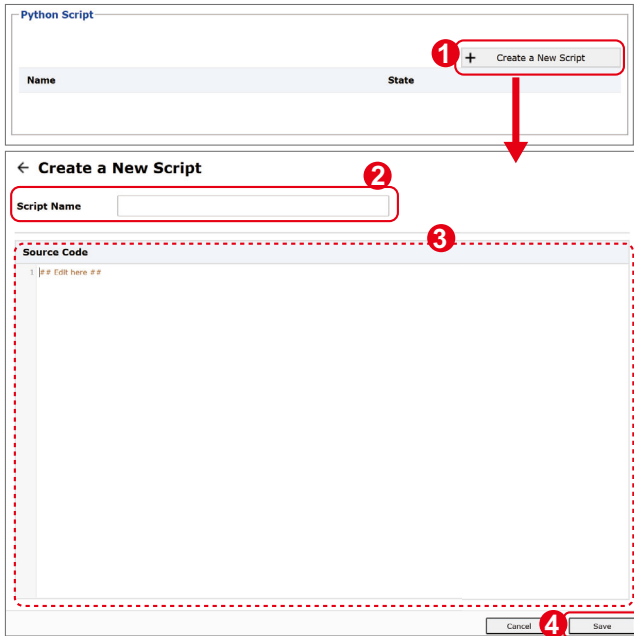

1. Click on Create a New Script button.
2. Enter the script name.
3. Enter your source code.
4. Save your script.

Note: You can create up to 4 scripts.

Script Management

From the script list, click on the script you'd like to run to enter the script.

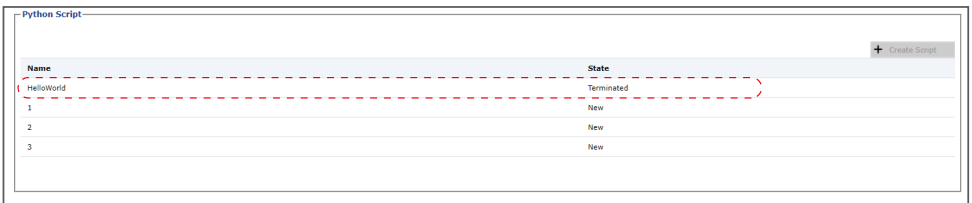

The script detail page offers you the following function and information:

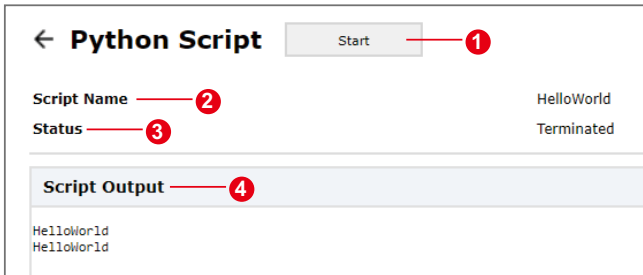

No.	Item	Description
1	Start	Click the button to run the script.
2	Script Name	Shows the name of this script.
3	Status	Shows the status of this script. <ul style="list-style-type: none"> ♦ New: A new script that has never been executed. ♦ Terminated: The script has been successfully executed, and its returned result is displayed in Script Output field. ♦ Run: The script is in running process.

No.	Item	Description
4	Script Output	Displays the messages detailing the success or failure of each operation.

ATEN Python Library

Use the following to write your Python script.

Get Outlet Info

To get the information about current, voltage, power, frequency, or status of the outlet.

- ◆ **Syntax**

```
atenPythonLib.getOutletInfo(port, target, station=1)
```

- ◆ **Example**

1. To get the status of station 1 outlet 1:

```
atenPythonLib.getOutletInfo(1, "status", 1)
```

2. To get the current information about station 1 outlet 1:

```
atenPythonLib.getOutletInfo(1, "curr")
```

Get inlet Info

To get the information about current, voltage, power, or frequency of the inlet.

- ◆ **Syntax**

```
atenPythonLib.getInletInfo(port, target, station=1)
```

- ◆ **Example**

1. To get the power information of station 1 inlet 1:

```
atenPythonLib.getInletInfo(1, "pow", 1)
```

2. To get the current information of station 1 inlet 1:

```
atenPythonLib.getInletInfo(1, "curr")
```

Get Bank Info

To get the information about current, voltage, power, or frequency of the bank.

- ◆ Syntax

```
atenPythonLib.getBankInfo(port, target,  
station=1)
```

- ◆ Example

1. To get the power information of station 1 bank 1:

```
atenPythonLib.getBankInfo(1, "pow")
```

2. To get the current information of station 1 bank 1:

```
atenPythonLib.getBankInfo(1, "curr")
```

Change Outlet Status

To turn on or off the outlet.

- ◆ Syntax

```
atenPythonLib.changeOutletStatus(port, action,  
station=1)
```

- ◆ Example

1. To turn on the outlet 1 of station 1:

```
atenPythonLib.changeOutletStatus(1, "on")
```

2. To turn off the outlet 1 of station 1:

```
atenPythonLib.changeOutletStatus(1, "off")
```

Get Sensor Info

To get the information about the temperature, humidity, and press of the connected sensor.

- ◆ Syntax

```
atenPythonLib.getSensorInfo(port, target,  
extPort=1, station=1)
```

◆ Example

1. To get the temperature information of the sensor connected to station 1's sensor port:

```
atenPythonLib.getSensorInfo(1, "temp", 1)
```

2. To get the humidity information of the sensor connected to station 1's sensor port:

```
atenPythonLib.changeOutletStatus(1, "hum", 2)
```

This Page Intentionally Left Blank

Chapter 9

PDU

Overview

The *PDU* function is used to upgrade the eco PDU's firmware, and to backup and restore the device's configuration settings.

ATEN PG8308G

Energy User Log Setup **PDU**

Upgrade Main Firmware | Backup/Restore

Station List

- [C01] - [PG8308G] PG8308G
 - [01]
 - [02]
 - [03]
 - [04]
 - [05]
 - [06]
 - [07]
 - [08]

Firmware File

Check Main Firmware Version

Energy Box Name	Firmware Version
<input type="checkbox"/> 01. PG8308G [PG8308G]	Firmware Version: 1.0.092

MMCu version: 1.2.116

Filename:

GE Sensor

Energy Box Name	Firmware Version
<input type="checkbox"/> 01. PG8308G [PG8308G]	Firmware Version: 1.0.092

Filename:

Upgrade Main Firmware

The *Upgrade Main Firmware* page is used to upgrade the firmware of the eco PDU. When you click the Upgrade Main Firmware tab, the display opens with the Firmware file menu page, which looks similar to the one below:

Firmware File

Check Main Firmware Version

Energy Box Name	[PG8308G]	Firmware Version
<input type="checkbox"/> 01. PG8308G	[PG8308G]	Firmware Version: 1.0.092

MMCu version:1.2.116

Filename:

GE Sensor

Energy Box Name	[PG8308G]	Firmware Version
▼ <input type="checkbox"/> 01. PG8308G	[PG8308G]	Firmware Version: 1.0.092

Filename:

A description of the items shown in this panel are given in the table below:

Item	Description
Check Main Firmware Version	If you enable <i>Check Main Firmware Version</i> , the eco PDU’s current firmware compared with that of the upgrade file. If the current version is equal to or higher than the upgrade version, a popup message appears, to inform you of the situation and stops the upgrade procedure.
Energy Box Name	Lists all of the eco PDU devices. Check the checkboxes of the devices for which you want to upgrade.
F/W Version	Displays the eco PDU’s current firmware version.
Filename	As new versions of the firmware become available, they are posted onto our website for users to download. Click the <i>Browse</i> button to select the downloaded upgrade file.
Upgrade	Click this button to upgrade the firmware of the selected devices.
GE Sensor	Shows the information about the firmware of the eco PDU’s GE sensor.

Upgrading the Firmware

To upgrade the firmware / GE sensor firmware, refer to the UI snapshot on the preceding page, and do the following:

1. Go to our website and download the firmware upgrade file to a convenient location on your computer.
2. Click the *Browse* button to locate and select the downloaded firmware upgrade file.
3. Click **Upgrade** to start the upgrade procedure.
 - ◆ If you enabled *Check Main Firmware Version*, the current firmware is compared with that of the upgrade file. If the current version is equal to or higher than the upgrade version, a popup message appears, to inform you of the situation and stops the upgrade procedure.
 - ◆ If you didn't enable *Check Main Firmware Version*, the upgrade file is installed without comparing.
 - ◆ Once the upgrade completes successfully, the switch restarts automatically.
4. Log in again, and check the firmware version to be sure it is the new one.

Firmware Upgrade Recovery

When the eco PDU becomes unusable after a failed firmware upgrade, use the following firmware recovery procedure:

1. Power off the device.
2. Press and hold the Select button (see page 7).
3. While holding the Select button, do the following:
 - ◆ For PG5308 / PG6308 / PG8308, connect the power cord to an AC power source.
 - ◆ For PG8208, plug in the inlet cable, and then connect it to the external power source.

This procedure forces the device to boot using the factory default firmware. After normal operation is restored, the firmware upgrade process can be performed again.

Backup/Restore

Selecting Backup/Restore on the menu bar gives you the ability to back up the switch’s configuration and user profile information:

Station List

Energy Box Name	Filename
<input type="checkbox"/> 01. PG8308G [PG8308G]	Please select a file to restore ▾

Backup

Password:

Restore

Auto Mapping

Password:

Filename:

Station List

Station List lists the eco PDU only.

Station List

Energy Box Name	Filename
<input type="checkbox"/> 01. PG8308G [PG8308G]	Please select a file to restore ▾

Backup

To backup the device’s settings, do the following:

Backup

Password:

1. In the **Password** field, key in a password for the setting file to be backed up.

Note: Entering a password is optional. If you do enter a password, make a note of it, since you will need it to be able to restore the file.

2. Click **Save**.
3. When the browser asks what you want to do with the file, select **Save to disk**; then save it in a convenient location.

Restore

To restore a previous backup, do the following:

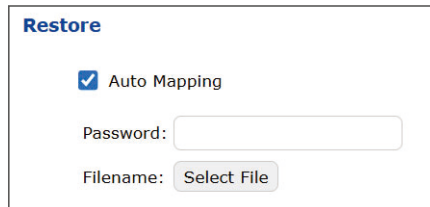

Restore

Auto Mapping

Password:

Filename:

1. Click **Browse**, navigate to the file and select it.

Note: If you have renamed the file, you can leave the new name as is. There is no need to return it to its original name.

2. In the *Password* field, key in the same password that you used to save the file.

Note: If you did not set a password when you created the backup file, you can omit this step.

3. Select as many of the options presented as you wish to restore.
4. Click **Restore**.

After the file is restored, a message appears to inform you that the procedure has completed successfully.

This Page Intentionally Left Blank

Chapter 10

LCD Menu

Readout Section on eco PDU

The readout section on ATEN eco PDU contains an LCD display for users to check the settings of the unit, and 3 buttons that deliver the following functions:

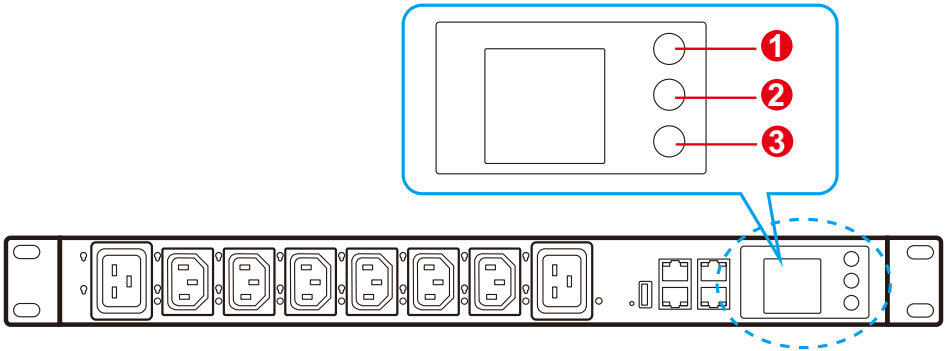

No.	Button	Description
1	MENU / BACK	Press the button to return to the previous page. Press and hold the button for 2 seconds to go back to the main menu.
2	SELECT	Press the button to cycle through the menu items.
3	ENTER	<ul style="list-style-type: none">◆ On home screen: Press the button to enter the main menu.◆ On main menu screen: Press the button to enter the page of the selected item for more information.

Home Screen

Once the unit is connected to an AC power source and turned on, home screen shows on the LCD display.

```

Device      (Standalone)
-IP1       -
-IP2       10.3.52.129
           0.00    A
           109.64  V
           0.0000  W
           0.0034  KWH
  
```

Item	Description	Supported Model		
		PG5308	PG6308	PG8208G PG8308
Device	Shows the unit status: <ul style="list-style-type: none"> ◆ Standalone The unit is without being connected to other PG series PDUs. ◆ Primary The unit is the master unit among the cascaded devices. ◆ Secondary The unit is the slave unit among the cascaded devices. 	✓	✓	✓
IP1 / IP2	Indicates the IP address of LAN 1 / LAN 2.	✓	✓	✓
A / V/ W / KWH	Provides the information about the current (A), the voltage (V), the wattage (W), and the power consumption (KWH) of the unit.	✓	✓	✓

Press ENTER button to enter the main menu page. See the following sections for more information and operation about the functions listed on the main menu.

Alert

On main menu screen, select **Alert** and press ENTER button to enter its page to check your alert settings. All eco PDU models support **Alert** function.



NO ALERT means that you have not set any threshold yet. To set alert(s), access the eco PDU via a supported Internet browser, log in with your username and password, go to **Energy > Connections**, and set the threshold(s) that triggers the alarm.

Measure

Users are able to check the following information about your eco PDU.

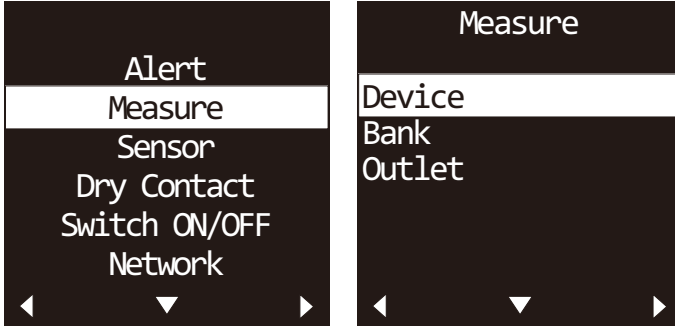

Item	Description	Supported Model		
		PG5308	PG6308	PG8208G PG8308
Device	Indicates the current (A), the voltage (V), the wattage (W), and the power consumption (KWH).	✓	✓	✓
Bank	Indicates the circuit breaker status, the load, the current (A), the voltage (V), the wattage (W), and the power consumption (KWH) of each of the individual banks.	✓	✓	✓
Outlet	Shows whether the outlet status is on, and the load, the current (A), the voltage (V), the wattage (W), and the power consumption (KWH) of each outlet.			✓

Sensor

Select **Sensor** on the main menu screen and enter its page to check the threshold settings of your installed sensor(s).

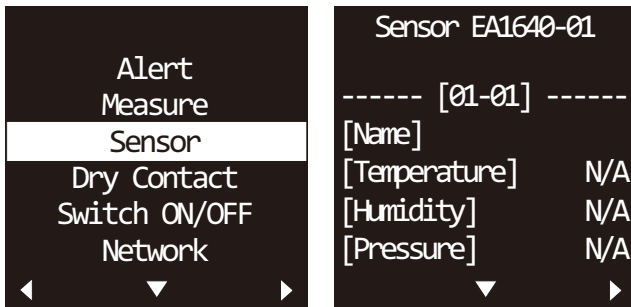

Access your eco PDU via a supported Internet browser, go to **Energy > Connections**, find **Sensor Status** to configure your settings.

Dry Contact

Dry Contact shows the status of the sensor that connected to the installed sensor, EA1640. Refer to *Sensor Config*, page 46 for how to set up the sensor(s) connected to EA1640.

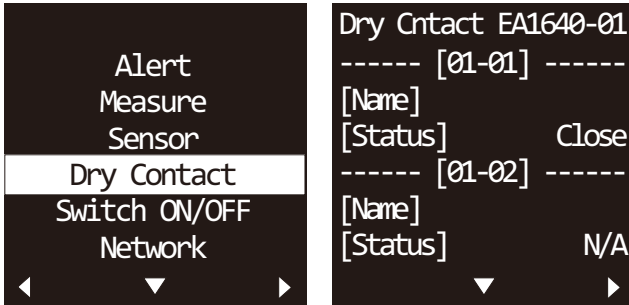

Item	Description	Supported Model		
		PG5308	PG6308	PG8208G PG8308
Name	The name you set for this connected sensor. See <i>Name</i> , page 46 for details.	✓	✓	✓
Status	The status of the connected sensor.	✓	✓	✓

Switch ON/OFF

Switch On/OFF is the function for user to change the power status of the eco PDU.

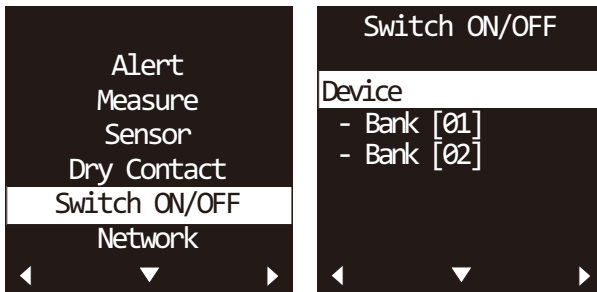

Item	Description	Supported Model		
		PG5308	PG6308	PG8208G PG8308
Switch ON/OFF	Change the power status of the unit / a bank / an outlet on the eco PDU.		✓	✓

On the main menu screen, select **Switch ON/OFF** and then press ENTER button to enter the detailed page, and depending on the model, you may enter the following subpages:

Device

Press ENTER button to enter **Device** detailed page. Press SELECT to choose the action and then press ENTER to take the selected action.

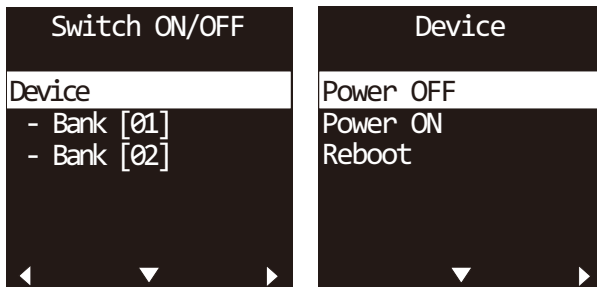

Item	Description	Supported Model		
		PG5308	PG6308	PG8208G PG8308
Power ON	Turn the unit on.		✓	✓
Power OFF	Turn the unit off.		✓	✓
Reboot	Reboot the unit.		✓	✓

Bank

On bank selection list, press SELECT button to select the bank you'd like to check, and then press ENTER button to select the following actions:

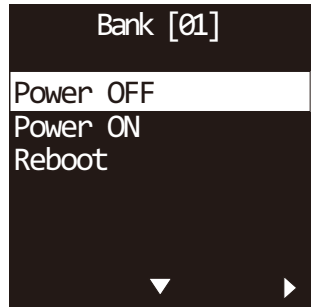
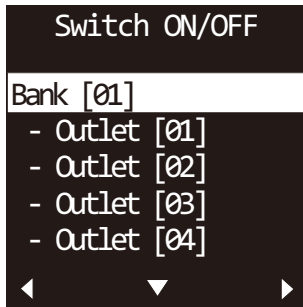
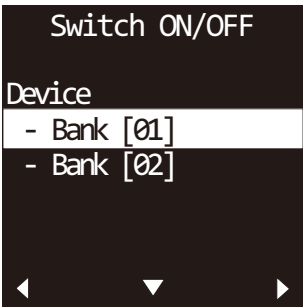

Item	Description	Supported Model		
		PG5308	PG6308	PG8208G PG8308
Power ON	Turn the bank on.		✓	✓
Power OFF	Turn the bank off.		✓	✓
Reboot	Reboot the bank.		✓	✓

Outlet

Press SELECT button to select the outlet to be checked and press ENTER button to enter the outlet detailed page to select the action to be taken:

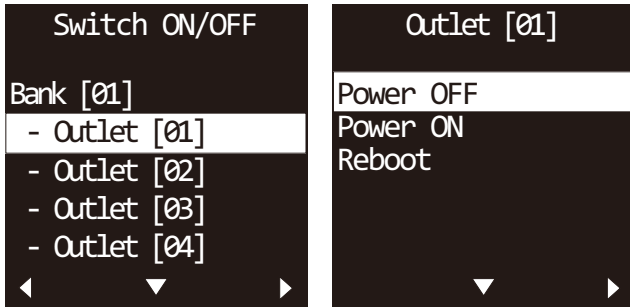

Item	Description	Supported Model		
		PG5308	PG6308	PG8208G PG8308
Power ON	Turn the outlet on.		✓	✓
Power OFF	Turn the outlet off.		✓	✓
Reboot	Reboot the outlet.		✓	✓

Network

Network page contains 2 subpages, **IP** and **Bridge**.

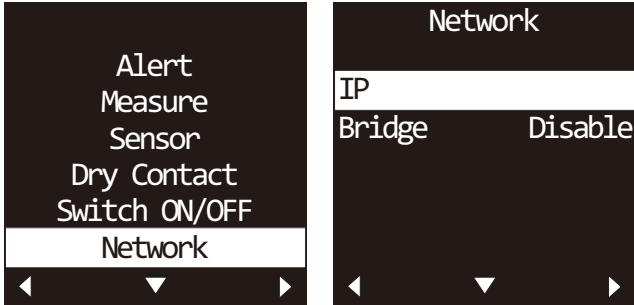

Item	Description	Supported Model		
		PG5308	PG6308	PG8208G PG8308
IP	The IPv4 or IPv6 configuration of LAN1, LAN 2, and Wi-Fi.	✓	✓	✓
Bridge	To cascade or bridge your eco PDUs, you have to enter the Bridge page to manually get the settings configured in advanced: <ul style="list-style-type: none"> ◆ Enable: For slave unit(s), enable the function Bridge. ◆ Disable: For master unit, please disable the function Bridge. 	✓	✓	✓

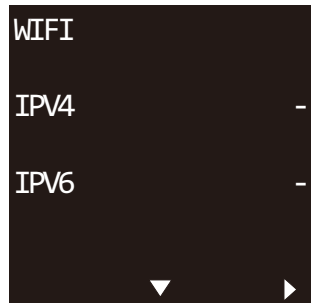
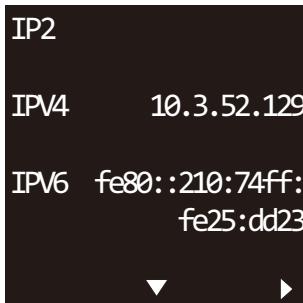

Cascade

Cascade page displays the eco PDU's status as illustrated below:

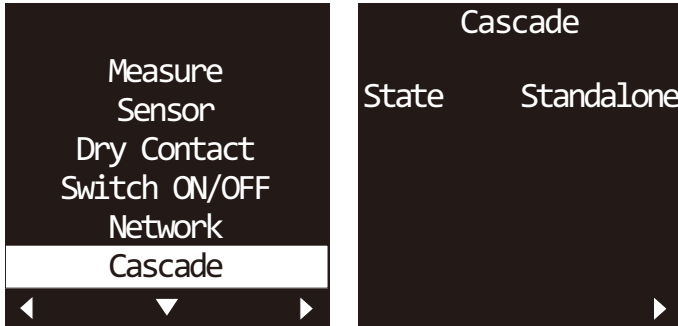

Item	Description	Supported Model		
		PG5308	PG6308	PG8208G PG8308
State	State shows which mode this eco PDU is in: <ul style="list-style-type: none"> ◆ Standalone: The unit is without being connected to other PG series PDUs. ◆ Primary: The unit is the master unit among the cascaded devices. ◆ Secondary: The unit is the slave unit among the cascaded devices. 	✓	✓	✓
ID	ID indicates the order of the unit among the cascaded device. This item is only available when the unit's status is Primary or Secondary.	✓	✓	✓

Settings

Enter the Settings page to configure the following:

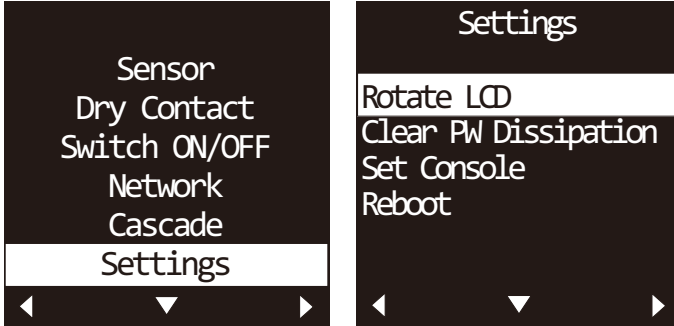

Item	Description	Supported Model		
		PG5308	PG6308	PG8208G PG8308
Rotate LCD	Enter the page to set the degree to rotate the LCD.	✓	✓	✓
Clear PW Dissipation	Enter the detailed page to select Clear to clear the power dissipation information.	✓	✓	✓
Set Console	Select the console mode between RS232 , RS485 , and PON . See <i>Serial Settings</i> for details.	✓	✓	✓
Reboot	Reboot the eco PDU.	✓	✓	✓
Reset to Default	Reset the eco PDU to factory default settings.	✓	✓	✓

Log

To download the event log of your eco PDU, please insert a USB drive to USB Type-A port in advanced. See *USB Type-A port*, page 13 for details.

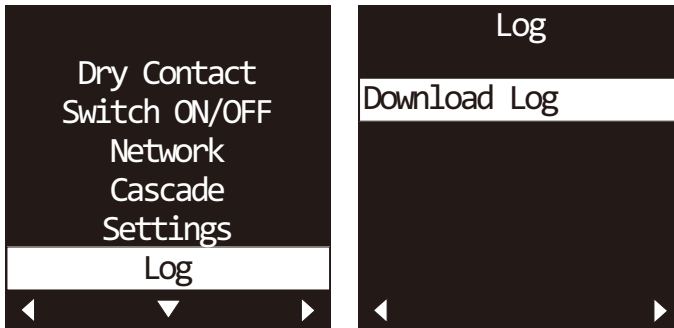

Item	Description	Supported Model		
		PG5308	PG6308	PG8208G PG8308
Download Log	Download the event logs of this unit and save the log file to the connected USB drive. Please note that the log file is encrypted and only for trouble shooting purpose.	✓	✓	✓

PDU

To back up or restore the configurations of the eco PDU, or to perform firmware upgrade, please insert a USB drive to USB Type-A port in advanced. See *USB Type-A port*, page 13 for details.

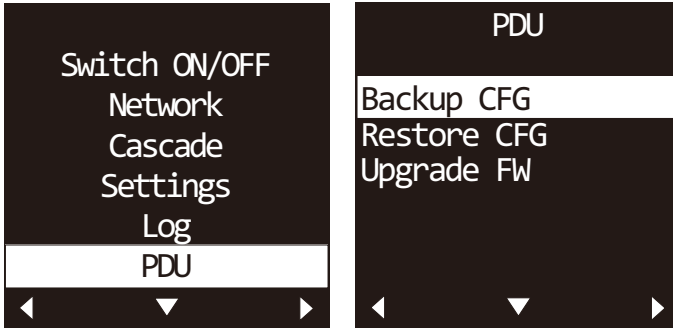

Item	Description	Supported Model		
		PG5308	PG6308	PG8208G PG8308
Backup CFG	Back up the configurations of your eco PDU and save it to the connected USB drive.	✓	✓	✓
Restore CFG	Import the file saved on the connected USB drive to restore the configurations of your eco PDU.	✓	✓	✓
Upgrade FW	Use the file saved on the connected USB drive to upgrade the firmware of the eco PDU.	✓	✓	✓

Chapter 11

Telnet Commands

Remote Terminal Operations

With ATEN eco PDU you can log in remotely from a computer using Telnet interface that allows system control through a high-end controller or PC.

Telnet

Telnet is a program that connects to a device over a network to provide text-based management and control. Telnet provides some of the same management features found in the eco PDU's web GUI. You can reference the eco PDU's web GUI functions by downloading the user manual from our website (www.aten.com). This can help you as you work your way through the text-based commands used to control the eco PDU that are discussed in this guide.

Telnet is available on all eco PDUs installed with the latest firmware. You can log in to the eco PDU via Telnet from any computer connected to the same network.

Setup

Log in to the eco PDU's web GUI, go to the **Setup** tab and click **Security** from the menu bar. Under **Working Mode**, check *Enable Telnet Server* and then click **Save** at the bottom of the page.

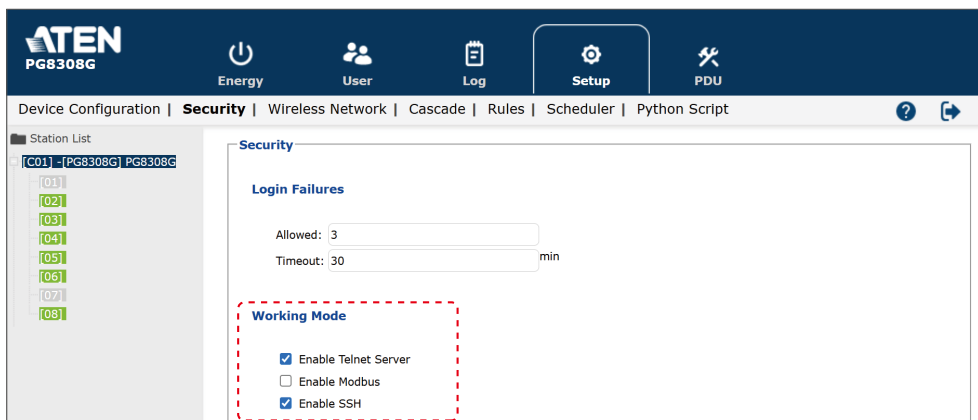

Note: If the *Enable Telnet Server* option is not available, please download the latest firmware from our website.

Logging In

To log in to the eco PDU via Telnet, do the following:

1. On your computer, open the start menu and select *Run*, type *cmd* into Open field, and click *OK*.

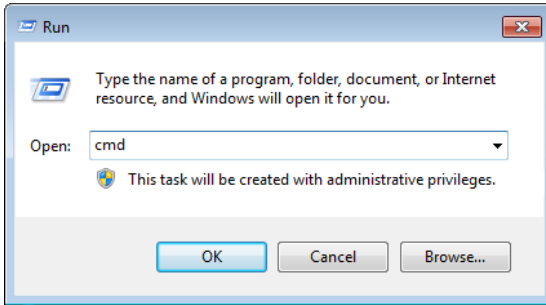

2. At the command prompt, key in *telnet* and the IP Address of the PDU, as follows:

```
telnet [IP Address]
```

3. Press *Enter*. The login screen appears:

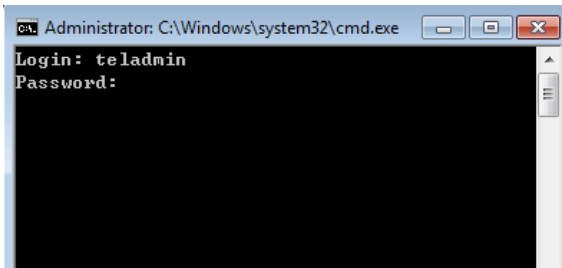

4. At the login prompt, enter the following:
 - ◆ username: **teladmin**
 - ◆ password: **telpwd**

Note: The Telnet username and password can be configured on the User tab of the eco PDU's web GUI.

- When the Telnet session is established, *Logged in successfully* appears along with the command line prompt:

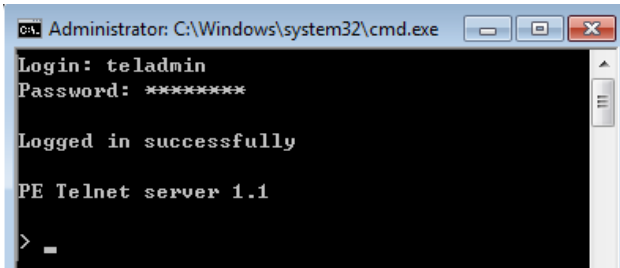
A screenshot of a Windows command prompt window titled "Administrator: C:\Windows\system32\cmd.exe". The window has a black background with white text. The text displayed is: "Login: teladmin", "Password: ****", "Logged in successfully", "PE Telnet server 1.1", and a prompt ">".

```
Administrator: C:\Windows\system32\cmd.exe
Login: teladmin
Password: ****
Logged in successfully
PE Telnet server 1.1
>
```

Session Timeout

A live Telnet connection would be terminated if there is no incoming data with 60 Seconds.

Commands

Use the Telnet commands to view and configure the eco PDU as described in each section. The text-based command line provides some of the same functions found under the Energy tab of the eco PDU's web-based GUI. Commands to view and configure the eco PDU are provide in the following sections. You can reference information provided in the user manual for the functions as you use the commands.

Verification

After sending an incorrect command, a verification message appears at the end of the command line.

- ◆ **Invalid command or exceed max command length:** The command has the wrong format and/or values. Try typing in the command string again using the correct format and/or values.

Read Power Outlet Status

The Read Power Outlet Status command allows you to view the power status of an outlet on the eco PDU.

The formula for Read Outlet Status commands is as follows:

Command + Outlet + Number + Option + [Enter]

1. For example, if you want to read the status of outlet 01 with a simple return string, type the following:

```
read status o01 simple [Enter]
```

2. For example, if you want to read the status of outlet 12 with a format return string, type the following:

```
read status o12 format [Enter]
```

The following tables show the possible values for the Read Outlet Status commands:

Command	Description
read status	Read status command

Outlet	Description
o	Outlet command
xx	PDU Outlet number xx: Outlet on PDU (01–04) Example: o02

Option	Description
simple	Return simple string of the selected power outlet status
format	Return format string of the selected power outlet status

The following table lists the available Read Outlet Status commands:

Command	Outlet	Option	Enter	Description
read status	oXX	simple	[Enter]	Read the status of outlet XX with a simple return string. XX: Outlet number (01–04)
read status	oXX	format	[Enter]	Read the status of outlet XX with a format return string. XX: Outlet number (01–04)

Note: 1. Each command string can be separated with a space.

2. The **Option** command string can be skipped and **format** will be used by default.

Switch Outlet Status

The Switch Outlet Status command allows you to change the power status of an outlet on the eco PDU.

The formula for Switch Outlet Status commands is as follows:

Command + Outlet + Number + Option + Control + [Enter]

1. For example, if you want to switch off outlet 04 immediately, type the following:

```
sw o04 imme off [Enter]
```
2. For example, if you want to switch on outlet 01 with the time delay set for the outlet, type the following:

```
sw o01 delay on [Enter]
```
3. For example, if you want to reboot outlet 03, type the following:

```
sw o03 reboot [Enter]
```

The following tables show the possible values for the Switch Outlet Status commands:

Command	Description
sw	Switch outlet status command

Outlet	Description
o	Outlet command
xx	PDU Outlet number xx: Outlet on PDU (01–04) Example: o02

Option	Description
imme	Switch outlet status immediately
delay	Switch outlet status with pre-configured delay time

Control	Description
on	Switch outlet on
off	Switch outlet off
reboot	Switch outlet off and then switch outlet on

The following table lists the available Switch Outlet Status commands:

Command	Outlet	Option	Control	Enter	Description
sw	oXX	imme delay	on	[Enter]	Switch outlet XX on with option imme or delay. XX: Outlet number (01-04)
sw	oXX	imme delay	off	[Enter]	Switch outlet XX off with option imme or delay. XX: Outlet number (01-04)
sw	oXX		reboot	[Enter]	Switch outlet XX off and on. XX: Outlet number (01-04)

Note: 1. Each command string can be separated with a space.

2. The **Option** command string can be skipped and **delay** will be used by default.

Read Environmental Value

The Read Environmental Value command allows you to view measurements from the eco PDU's environmental sensors.

The formula for Read Environmental Value commands is as follows:

Command + Outlet + Number + Option + [Enter]

1. For example, if you want to read environmental sensor 02 with a simple return string, type the following:

```
read sensor o02 simple [Enter]
```

2. For example, if you want to read environmental sensor 01 with a format return string, type the following:

```
read sensor o01 format [Enter]
```

The following tables show the possible values for the Read Environmental Value commands:

Command	Description
<code>read sensor</code>	Read environmental sensor value command.

Outlet	Description
<code>o</code>	Outlet with environmental sensor installed command
<code>xx</code>	PDU Outlet number with environmental sensor installed <code>xx</code> : Outlet on PDU (01-04) Example: <code>o02</code>

Option	Description
<code>simple</code>	Return simple string of the environmental sensor value on the selected power outlet with environmental sensor installed.
<code>format</code>	Return format string of the environmental sensor value on the selected power outlet with environmental sensor installed.

The following table lists the available Read Environmental Value commands:

Command	Sensor	Option	Enter	Description
read sensor	oXX	simple format	[Enter]	Read the environmental sensor value on the selected power outlet with environmental sensor installed. Outlet XX with option simple or format. XX: Outlet number (01–04).

Note: 1. Each command string can be separated with a space.

2. The **Option** command string can be skipped and **format** will be used by default.

Close Telnet Session

The Close Telnet Session command allows you to disconnect the telnet session from the eco PDU.

The formula for the Close Telnet Session command is as follows:

Command + [Enter]

1. For example, if you want to disconnect the telnet session, type the following:

quit [Enter]

The following table shows the value for the Close Telnet Session command:

Command	Description
quit	Close telnet session command

The following table lists the Close Telnet Session command:

Command	Enter	Description
quit	[Enter]	Disconnects telnet session with PG95 / PG96 / PG98 3-Phase 30-Outlet 0U PDU.

Reboot PDU Device

The Reboot PDU Device command allows you to reboot the eco PDU.

The formula for Reboot PDU Device commands is as follows:

Command + [Enter]

1. For example, if you want to reboot the eco PDU, type the following:

reboot [Enter]

The following tables show the possible values for the Read Environmental Value commands:

Command	Description
reboot	Reboot PDU device command

The following table lists the available Reboot PDU Device command:

Command	Enter	Description
reboot	[Enter]	Reboots the eco PDU.

Safety Instructions

General

- ◆ This product is for indoor use only.
- ◆ Read all of these instructions. Save them for future reference.
- ◆ Follow all warnings and instructions marked on the device.
- ◆ Do not place the device on any unstable surface (cart, stand, table, etc.). If the device falls, serious damage will result.
- ◆ Do not use the device near water.
- ◆ Do not place the device near, or over, radiators or heat registers.
- ◆ The device cabinet is provided with slots and openings to allow for adequate ventilation. To ensure reliable operation, and to protect against overheating, these openings must never be blocked or covered.
- ◆ The device should never be placed on a soft surface (bed, sofa, rug, etc.) as this will block its ventilation openings. Likewise, the device should not be placed in a built in enclosure unless adequate ventilation has been provided.
- ◆ Never spill liquid of any kind on the device.
- ◆ Unplug the device from the wall outlet before cleaning. Do not use liquid or aerosol cleaners. Use a damp cloth for cleaning.
- ◆ The device should be operated from the type of power source indicated on the marking label. If you are not sure of the type of power available, consult your dealer or local power company.
- ◆ To prevent damage to your installation it is important that all devices are properly grounded.
- ◆ The device is equipped with a 3-wire grounding type plug. This is a safety feature. If you are unable to insert the plug into the outlet, contact your electrician to replace your obsolete outlet. Do not attempt to defeat the purpose of the grounding-type plug. Always follow your local/national wiring codes.
- ◆ The equipment should be installed near the wall socket outlet and the disconnect device (appliance coupler on detachable power supply cord or plug on non-detachable power supply cord) should be readily accessible.

- ◆ Do not allow anything to rest on the power cord or cables. Route the power cord and cables so that they cannot be stepped on or tripped over.
- ◆ To help protect your system from sudden, transient increases and decreases in electrical power, use a surge suppressor, line conditioner, or uninterruptible power supply (UPS).
- ◆ Position system cables and power cables carefully; Be sure that nothing rests on any cables.
- ◆ When connecting or disconnecting power to hot pluggable power supplies, observe the following guidelines:
 - ◆ Install the power supply before connecting the power cable to the power supply.
 - ◆ Unplug the power cable before removing the power supply.
 - ◆ If the system has multiple sources of power, disconnect power from the system by unplugging all power cables from the power supplies.
- ◆ Never push objects of any kind into or through cabinet slots. They may touch dangerous voltage points or short out parts resulting in a risk of fire or electrical shock.
- ◆ Do not attempt to service the device yourself. Refer all servicing to qualified service personnel.
- ◆ If the following conditions occur, unplug the device from the wall outlet and bring it to qualified service personnel for repair.
 - ◆ The power cord or plug has become damaged or frayed.
 - ◆ Liquid has been spilled into the device.
 - ◆ The device has been exposed to rain or water.
 - ◆ The device has been dropped, or the cabinet has been damaged.
 - ◆ The device exhibits a distinct change in performance, indicating a need for service.
 - ◆ The device does not operate normally when the operating instructions are followed.
- ◆ Only adjust those controls that are covered in the operating instructions. Improper adjustment of other controls may result in damage that will require extensive work by a qualified technician to repair.
- ◆ Do not connect the RJ-11 connector marked “Sensor” to a public telecommunication network.
- ◆ Caution: Double pole, neutral fusing. Disconnect mains before servicing.
- ◆ Information prior to installation and initial use

- ◆ Instructions for installation and interconnection
- ◆ Equipment intended for use only in restricted access area
- ◆ Protective earthing used as a safeguard
- ◆ Protective conductor current exceeding ES2 limits
- ◆ Plugs as disconnect devices
- ◆ CAUTION: Risk of Explosion if Battery is replaced by an Incorrect Type. Dispose of Used Batteries According to the Instructions.

Rack Mounting

- ◆ Before working on the rack, make sure that the stabilizers are secured to the rack, extended to the floor, and that the full weight of the rack rests on the floor. Install front and side stabilizers on a single rack or front stabilizers for joined multiple racks before working on the rack.
- ◆ Always load the rack from the bottom up, and load the heaviest item in the rack first.
- ◆ Make sure that the rack is level and stable before extending a device from the rack.
- ◆ Use caution when pressing the device rail release latches and sliding a device into or out of a rack; the slide rails can pinch your fingers.
- ◆ After a device is inserted into the rack, carefully extend the rail into a locking position, and then slide the device into the rack.
- ◆ Do not overload the AC supply branch circuit that provides power to the rack. The total rack load should not exceed 80 percent of the branch circuit rating.
- ◆ Make sure that all equipment used on the rack – including power strips and other electrical connectors – is properly grounded.
- ◆ Ensure that proper airflow is provided to devices in the rack.
- ◆ Ensure that the operating ambient temperature of the rack environment does not exceed the maximum ambient temperature specified for the equipment by the manufacturer
- ◆ Do not step on or stand on any device when servicing other devices in a rack.

The eco PDU's Main Power Cord

Use the power cord supplied with this package. If it becomes necessary to replace the cord supplied with this package, be sure to use a cord of at least the same standard as the one provided.



Securing the Power Cables

To secure the cables in the eco PDU's power outlets, use only the ATEN Lock-Your-Plug cable holders that have been specifically designed to work with the eco PDU. Using any other kind of cable securing device could be highly dangerous. Please contact your ATEN dealer for information about ATEN Lock-Your-Plugs.

Resetting the Circuit Breaker

Before switching the circuit breaker to reset a trip, power down and disconnect all devices connected to the eco PDU's power outlets to prevent damage caused by a sudden power surge. If a power surge causes the eco PDU's circuit breaker to switch off the power and it needs to be reset, follow the instructions below.

Recovery Procedure:

1. Safely power down and disconnect all devices connected to the eco PDU's power outlets.
2. Switch off the circuit breaker for the source that is providing power to the eco PDU.
3. Switch the eco PDU's circuit breaker to reset the trip.
4. Switch on the circuit breaker for the source that is providing power to the eco PDU.
5. Reconnect the devices to the eco PDU's power outlets, and power them on.

Technical Support

International

- ◆ For online technical support – including troubleshooting, documentation, and software updates: <http://eservice.aten.com>
- ◆ For telephone support, see *Telephone Support* on page iv.

North America

Email Support		support@aten-usa.com
Online Technical Support	Troubleshooting Documentation Software Updates	http://www.aten-usa.com/ support
Telephone Support		1-888-999-ATEN ext 4988

When you contact us, please have the following information ready beforehand:

- ◆ Product model number, serial number, and date of purchase.
- ◆ Your computer configuration, including operating system, revision level, expansion cards, and software.
- ◆ Any error messages displayed at the time the error occurred.
- ◆ The sequence of operations that led up to the error.
- ◆ Any other information you feel may be of help.

IP Address Determination

If you are an administrator logging in for the first time, you need to access the eco PDU in order to give it an IP address that users can connect to. There are two methods to choose from. In each case, your client computer must be on the same network segment as the eco PDU. After you have connected and logged in, you can give the device a fixed network address. (See *Device Management*, page 57.)

Method 1

For computers running Windows, an IP address can be determined and/or assigned with the IP Installer utility. The utility can be obtained from the *Download* area of our website or from the software CD. Look under *Driver/SW*, and the model of your device. After downloading the utility to your computer, do the following:

1. Unzip the contents of *IPInstaller.zip* to a directory on your hard drive.
2. Go to the directory that you unzipped the IPInstaller program to and run *IPInstaller.exe*. A dialog box similar to the one below appears:

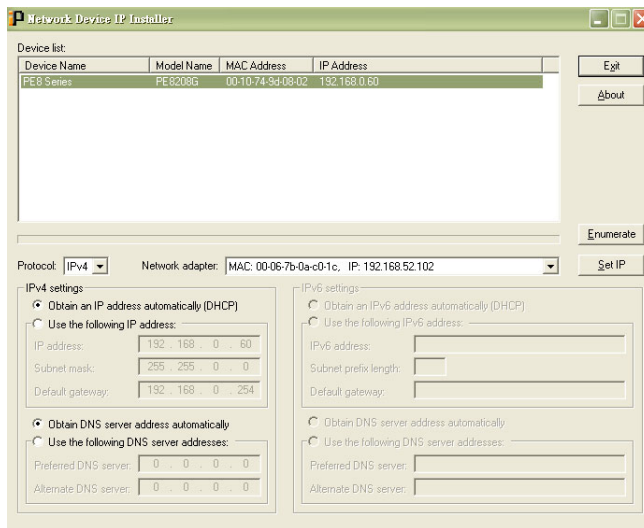

3. Select the device from the *Device List*.

Note: 1. If the list is empty, or your device doesn't appear, click **Enumerate** to refresh the Device List.

2. If there is more than one device in the list, use the MAC address to pick the one you want. The eco PDU's MAC address is located on its bottom panel.

4. Select either *Obtain an IP address automatically (DHCP)*, or *Specify an IP address*. If you chose the latter, fill the IP Address, Subnet Mask, and Gateway fields with the information appropriate to your network.
5. Click **Set IP**.
6. After the IP address shows up in the Device List, click **Exit** to end the program.

Method 2

1. Set your computer's IP address to 192.168.0.XXX
Where XXX represents any number or numbers except 60 (192.168.0.60 is the default address of the eco PDU).
2. Specify the device's default IP address (192.168.0.60) in your browser to access it.
3. Assign a fixed IP address for the device (see *IPv4 Configuration*, page 59), that is suitable for the network segment that it resides on.
4. After you log out, reset your computer's IP address to its original value.
5. Once you have logged in, go to Network Settings to set up the permanent IP environment (see *IPv4 Configuration*, page 59).

Method 3

ATEN eco DC allows you to determine/assign an IP address in order to configure a PDU device and monitor power status of the equipment connected to it. ATEN eco DC can be obtained from the Download area of the ATEN website.

Specifications

PG5308A / PG5308B / PG5308G

Function	PG5308A	PG5308B	PG5308G
Electrical			
Nominal Input Voltage	100–120 VAC	100–240 VAC	100–240 VAC
Maximum Input Current	30A Max, 24A (UL)	30A Max, 24A (UL)	32A Max
Input Frequency	50–60 Hz		
Input Connection	NEMA L5-30P	NEMA L6-30P	IEC 60309 32A
Input Power	3600VA (Max), 2880VA (UL)	7200VA (Max), 5760VA (UL)	7680VA (Max)
Outlet Type	8 × NEMA 5-20R	6 × IEC320 C13 2 × IEC320 C19	6 × IEC320 C13 2 × IEC320 C19
Nominal Output Voltage	100–120 VAC	100–240 VAC	100–240 VAC
Maximum Output Current (Outlet)	20A (Max), 16A (UL)	C13: 12A (UL) C19: 16A (UL)	C13: 10A (Max) C19: 16A (Max)
Breakers	UL489 × 2		
Metering	Bank level Current, Voltage, PF and kWh Monitoring		
Outlet Switching	No		
Environment Sensor Ports	1 × RJ-45		
USB 2.0 Type-A Port	Yes		
Ethernet Port	10/100/1000M		
PON + COM Port	1 × RJ-45		
Metering Accuracy	1%		
Physical Properties			
Dimensions (L × W × H)	43.24 × 21.00 × 4.40 cm (17.02 × 8.27 × 1.73 in.)		

Function	PG5308A	PG5308B	PG5308G
Weight	4.27 kg (9.41 lb)	4.57 kg (10.08 lb)	3.99 kg (8.80 lb)
Power Cord Length	3M (SR + NEMA L5-30P)	3M (SR + NEMA L6-30P)	3M (SR + IEC60309 32A)
Environmental			
Temperature (Operating / Storage)	0–60°C/ –20–60°C		
Humidity (Operating & Storage)	0–80% RH, Non-Condensing		
Compliance			
EMC Verification	FCC	FCC	CE
Safety Verification	UL, PSE	UL, PSE	CE, UKCA

PG6308A / PG6308B / PG6308G

Function	PG6308A	PG6308B	PG6308G
Electrical			
Nominal Input Voltage	100–120 VAC	100–240 VAC	100–240 VAC
Maximum Input Current	30A Max, 24A (UL)	30A Max, 24A (UL)	32A Max
Input Frequency	50–60 Hz		
Input Connection	NEMA L5-30P	NEMA L6-30P	IEC 60309 32A
Input Power	3600VA (Max), 2880VA (UL)	7200VA (Max), 5760VA (UL)	7680VA (Max)
Outlet Type	8 × NEMA 5-20R	6 × IEC320 C13 2 × IEC320 C19	6 × IEC320 C13 2 × IEC320 C19
Nominal Output Voltage	100–120 VAC	100–240 VAC	100–240 VAC
Maximum Output Current (Outlet)	20A (Max), 16A (UL)	C13:12A (UL) C19:16A (UL)	C13:10A (UL) C19:16A (UL)
Breakers	UL489 × 2		
Metering	Bank level Current, Voltage , PF and KWh Monitoring		
Outlet Switching	Yes		
Environment Sensor Ports	1 × RJ-45		
USB 2.0 Type-A Port	Yes		
Ethernet Port	10/100/1000M		
PON + COM Port	1 × RJ-45		
Metering Accuracy	1%		
Physical Properties			
Dimensions (L × W × H)	43.24 × 21.00 × 4.40 cm (17.02 × 8.27 × 1.73 in.)		
Weight	4.37 kg (10.24 lb)	4.68 kg (10.32 lb)	4.09 kg (9.02 lb)

Function	PG6308A	PG6308B	PG6308G
Power Cord Length	3M (SR + NEMA L5-30P)	3M (SR + NEMA L6-30P)	(SR + IEC60309 32A)
Environmental			
Temperature (Operating / Storage)	0–60°C/ –20–60°C		
Humidity (Operating & Storage)	0–80% RH, Non-Condensing		
Compliance			
EMC Verification	FCC	FCC	CE
Safety Verification	UL, PSE	UL, PSE	CE, UKCA

PG8308A / PG8308B / PG8308G

Function	PG8308A	PG8308B	PG8308G
Electrical			
Nominal Input Voltage	100–120 VAC	100–240 VAC	100–240 VAC
Maximum Input Current	30A Max, 24A (UL)	30A Max, 24A (UL)	32A Max
Input Frequency	50–60 Hz		
Input Connection	30A Max, 24A (UL)	NEMA L6-30P	IEC 60309 32A
Input Power	3600VA (Max), 2880VA (UL)	7200VA (Max), 5760VA (UL)	7680VA (Max)
Outlet Type	8 × NEMA 5-20R	6 × IEC320 C13 2 × IEC320 C19	6 × IEC320 C13 2 × IEC320 C19
Nominal Output Voltage	100–120 VAC	100–240 VAC	100–240 VAC
Maximum Output Current (Outlet)	20A (Max), 16A (UL)	C13: 15A (Max), 12A (UL) C19: 20A (Max), 16A (UL)	C13: 10A (Max) C19: 16A (Max)
Breakers	UL489 × 2		
Metering	Per Outlet level Current, Voltage, PF and KWh Monitoring		
Outlet Switching	Yes		
Environment Sensor Ports	1 × RJ-45		
USB 2.0 Type-A Port	Yes		
Ethernet Port	10/100/1000M		
PON + COM Port	1 × RJ-45		
Metering Accuracy	1%		
Physical Properties			
Dimensions (L × W × H)	43.24 × 21.00 × 4.40 cm (17.02 × 8.27 × 1.73 in.)		

Function	PG8308A	PG8308B	PG8308G
Weight	4.35 kg (9.59 lb)	4.65 kg (10.24 lb)	4.07 kg (8.97 lb)
Power Cord Length	3M (SR+NEMA L5-30P)	3M (SR + NEMA L6-30P)	3M (SR + IEC60309 32A)
Environmental			
Temperature (Operating / Storage)	0–60°C/ –20–60°C		
Humidity (Operating & Storage)	0–80% RH, Non-Condensing		
Compliance			
EMC Verification	FCC	FCC	CE
Safety Verification	UL, PSE	UL, PSE	CE, UKCA

PG8208G

Function	PG8208G
Electrical	
Nominal Input Voltage	100–240 VAC
Maximum Input Current	16A Max
Input Frequency	50–60 Hz
Input Connection	IEC 60320 C20
Input Power	3840VA (Max)
Outlet Type	7 × IEC320 C13 1 × IEC320 C19
Nominal Output Voltage	100–240 VAC
Maximum Output Current (Outlet)	C13:10A (Max) C19:16A (Max)
Breakers	N/A
Metering	Per Outlet level Current, Voltage, PF and KWh Monitoring
Outlet Switching	Yes
Environment Sensor Ports	1 × RJ45
USB 2.0 Type-A Port	Yes
Ethernet Port	10/100/1000M
PON + COM Port	1 × RJ-45
Metering Accuracy	1%
Physical Properties	
Dimensions (L x W x H)	43.24 × 22.04 × 4.40 cm (17.02 × 8.68 × 1.73 in.)
Weight	2.7kg
Power Cord Length	3M (C19 + C20)
Environmental	
Temperature (Operating / Storage)	0–60°C/ –20–60°C
Humidity (Operating & Storage)	0–80% RH, Non-Condensing

Function	PG8208G
Compliance	
EMC Verification	CE
Safety Verification	CE, UKCA, PSE, UL

ATEN Warranty Policy

The warranty policy may vary by product category and region of purchase. For details, please visit ATEN's official website, select your purchase counties/regions and then go to the Support Center, or contact your local ATEN sales representative for further assistance.

Copyright © 2025–2026 ATEN® International Co., Ltd.

Released: 2026-01-20

ATEN and the ATEN logo are registered trademarks of ATEN International Co., Ltd. All rights reserved. All other brand names and trademarks are the registered property of their respective owners.