



Simply Better Connections

ATEN RBS Equipment & RBS Configurator

ATEN Room Booking System
User Manual

Compliance Statements

FEDERAL COMMUNICATIONS COMMISSION INTERFERENCE STATEMENT

This equipment has been tested and found to comply with the limits for a Class A digital device, pursuant to Part 15 of the FCC Rules. These limits are designed to provide reasonable protection against harmful interference when the equipment is operated in a commercial environment. This equipment generates, uses, and can radiate radio frequency energy and, if not installed and used in accordance with the instruction manual, may cause harmful interference to radio communications. Operation of this equipment in a residential area is likely to cause harmful interference in which case the user will be required to correct the interference at his own expense.

The device complies with Part 15 of the FCC Rules. Operation is subject to the following two conditions: (1) this device may not cause harmful interference, and (2) this device must accept any interference received, including interference that may cause undesired operation.

FCC Caution

Any changes or modifications not expressly approved by the party responsible for compliance could void the user's authority to operate this equipment.

Warning

Operation of this equipment in a residential environment could cause radio interference.

Achtung

Der Gebrauch dieses Geräts in Wohnumgebung kann Funkstörungen verursachen.



KCC Statement

유선 제품용 / A 급 기기 (업무용 방송 통신 기기)
이 기기는 업무용 (A 급) 전자파적합기기로서 판매자 또는 사용자는 이
점을 주의하시기 바라며, 가정 외의 지역에서 사용하는 것을 목적으로
합니다.

Industry Canada Statement

This Class A digital apparatus complies with Canadian ICES-003.

CAN ICES-003 (A) / NMB-003 (A)

RoHS

This product is RoHS compliant.

User Information

Online Registration

Be sure to register your product at our online support center:

International	http://eservice.aten.com
---------------	---

Telephone Support

For telephone support, call this number:

International	886-2-8692-699
China	86-400-810-0-810
Japan	81-3-61-811
Korea	82-2-467-6789
North America	1-888-999-ATEN ext 4988 1-949-428-1111

User Notice

All information, documentation, and specifications contained in this manual are subject to change without prior notification by the manufacturer. The manufacturer makes no representations or warranties, either expressed or implied, with respect to the contents hereof and specifically disclaims any warranties as to merchantability or fitness for any particular purpose. Any of the manufacturer's software described in this manual is sold or licensed *as is*. Should the programs prove defective following their purchase, the buyer (and not the manufacturer, its distributor, or its dealer), assumes the entire cost of all necessary servicing, repair and any incidental or consequential damages resulting from any defect in the software.

The manufacturer of this system is not responsible for any radio and/or TV interference caused by unauthorized modifications to this device. It is the responsibility of the user to correct such interference.

The manufacturer is not responsible for any damage incurred in the operation of this system if the correct operational voltage setting was not selected prior to operation. PLEASE VERIFY THAT THE VOLTAGE SETTING IS CORRECT BEFORE USE.

Product Information

For information about all ATEN products and how they can help you connect without limits, visit ATEN on the Web or contact an ATEN Authorized Reseller. Visit ATEN on the Web for a list of locations and telephone numbers:

International	http://www.aten.com
North America	http://www.aten-usa.com

Package Contents

Check to make sure that all components are in working order. If you encounter any problem, please contact your dealer.

VK401

- ◆ VK401 Access Inspector
- ◆ 2 screws
- ◆ 1 user instructions

VK430

Due to a package contents change, you may receive one of the following package editions:

Latest Package Edition

- ◆ 1 VK430 10.1" RBS Panel with 2 x LED light bars
- ◆ 1 wall mount kit
- ◆ 2 3M glass mount tape
- ◆ 1 90° RJ-45 cable adapter
- ◆ 1 user instructions

Previous Package Edition

- ◆ 1 VK430 10.1" RBS Panel with wall mount
- ◆ 2 LED bars
- ◆ 4 LED bar screws
- ◆ 4 hard wall mount screws + screw anchors
- ◆ 2 3M glass mount tape 1 user instructions

VR610

- ◆ 1 VR610 infoPlayer
- ◆ 1 PIR cable
- ◆ 1 user instructions

Contents

Compliance Statements	ii
User Information	iv
Online Registration	iv
Telephone Support	iv
User Notice	iv
Product Information	v
Package Contents	vi
VK401	vi
VK430	vi
VR610	vi
Contents	vii
About this Manual	xii
Conventions	xiii

1. Introduction

Overview	1
ATEN Access Inspector (VK401)	1
ATEN infoPlayer (VR610)	3
Features	4
RBS Configurator	4
ATEN Access Inspector (VK401)	4
VK430 10.1" RBS Panel	5
ATEN infoPlayer (VR610)	6
Requirements	7
Getting Started	8
Setting Up ATEN RBS Panels and Calendar Servers	8
Setting Up the infoPlayer	9
Setting Up Access Inspector	10
Accessories	12

2. Hardware Setup

ATEN Access Inspector	13
Components	13
Installing an Access Inspector to an RBS Panel	14
Obtaining Card Numbers	15
ATEN RBS Panel	16
Components	16
Installing an RBS Panel	18
ATEN infoPlayer	20
Components	20
Installing the infoPlayer	21

3. Configuring RBS Profiles

Installing/Updating RBS Configurator	23
The Main Screen of RBS Configurator	25
infoPlayer Profiles	27
Adding a new infoPlayer Profile	27
Configuring infoPlayer Profiles	29
Configuration Panel Overview	29
Configuring the infoPlayer Display Settings	31
Setting Up a Map View for the infoPlayer Display	37
Why Using the Map View	37
Switching between List View and Map View	39
Configuring a Map	40
Map & Widget Size	44
1080p Display	44
4K Display	45
Supported Widget Resolution from Different Input Source	46
Supported HDMI In Resolutions	46
RBS Panel Profiles	47
Adding New Panel Profiles	47
Adding Meeting Rooms	47
Adding Classrooms	48
Editing Profile Names, Duplicating and Deleting Profiles	50
Configuring Panel Profiles.	51
GUI Design	52
Overview	52
Blurring the Background	54
Booking Settings	56

4. Calendar Server

Microsoft 365	57
Setup Overview	57
Microsoft 365 Admin Center	58
Adding User Accounts.	58
Deciding the Authentication Method	59
Adding a Room (Resource) Account	60
Adding a User Account as Delegate	62
Turning Off Multifactor Authentication (MFA)	63
Configuring Microsoft Entra (for using Account Credentials)	65
Registering Application	65
Adding API Permissions	67
Configuring Microsoft Entra (for using Client Secret Keys)	70
Registering the Application	70
Adding API Permissions	74
Setting Up Microsoft 365 in ATEN RBS Configurator	77
Account Settings	77
Configuring Room Grouping	78
Microsoft Exchange Server	82

Setup Overview	82
Checking the Version of Your Microsoft Exchange Server	82
Microsoft Exchange 2013 / 2016 / 2019	84
Finding the Host Name	84
Creating a Room Mailbox	87
Adding the Room Mailbox to a Room List (Distribution Group) ..	89
Deciding the Authentication Method	93
Creating a Delegate Mailbox	94
Resetting Room Password	95
Configuring Impersonation Rights	96
Microsoft Exchange 2010	99
Finding the Host Name	99
Creating a Room Mailbox	102
Adding the Room Mailbox to a Room Distribution Group	104
Deciding the Authentication Method	107
Creating a Delegate Mailbox	107
Setting up a Password for the Room Mailbox	109
Configuring Impersonation Rights	112
Setting Up Microsoft Exchange in ATEN RBS Configurator	113
Account Settings	113
Setting Up Room Grouping	114
Google Workspace	116
Setting Up Google Workspace for Room Management	117
Adding Rooms, Buildings, and Users	117
Enabling Google Calendar and Admin API	122
Creating a Service Account	124
Authorizing Access from Third-party Applications	125
Setting Up Google Workspace in ATEN RBS Configurator	126
DingTalk	128
Panel Message	129
Disconnection Message	129
Support Contact	130

5. infoPlayer and RBS Panel Operation

Operating RBS Panels	131
Meeting Room Panel Main Page	131
Classroom Panel Main Page	134
Viewing Meeting Schedule	135
Today's Scheduled Meetings	135
Meetings Scheduled on Other Dates / for Other Rooms	136
Booking a Room	137
Using the Calendar	137
Scan & PIN Function	138
Splitting Room Name using Break Symbol	138
Using the Suggest Room Function Without Unizon	139
Using the Suggest Room Function With Unizon	141

Using Sign-on for Attendance Record with Unizon	144
Canceling a Reservation	145
Submitting User Request	146
Quick Submitting / Closing User Request	149
Administrator Settings	152
Enabling / Disabling Access to Basic Panel Settings	152
Configuring Network Settings	153
Setting the Password	154
Account Lockout	154
Obtaining Card Numbers	155
Enabling Demo Mode	156
Disabling Demo Mode	157
Operating an infoPlayer Display	158
Components Overview	158
Normal Mode	158
Spotlight Mode	159
Reserving a Meeting Room from an infoPlayer Display	160

6. Device Management

Managing the infoPlayer and RBS Panels via RBS Configurator	163
Loading Devices to RBS Configurator	163
Device Configuration Options	164
Adding RBS Panels to infoPlayer	168
Uploading Profiles to infoPlayer/RBS Panels	169
Batch Configure	171
Upgrading the RBS Panel Firmware	173
Upgrading the infoPlayer Firmware via RBS Configurator	175
Recovery Mode for infoPlayer	177
Updating the RBS Panel App	178
Managing Login Password Setting Panel Passwords	180
Panel Login	180
Changing Panel Passwords	181
Managing infoPlayer via the Web Console	183
Web Console Overview	183
The Dashboard	184
General Settings	184
Exporting System Logs	186
Configuring the Access Key and Lock Settings	186
Configuring the Device Network Settings	187
Configuring Display Resolution and Rotation	188
Viewing the Connection Status of RBS Panels	188
Enabling SSL	189

Appendix

Safety Instructions	191
General	191

Troubleshooting 193
 Microsoft 365 & Exchange 193
 Meeting Title and Details Cannot Be Shown on RBS Panels . . . 193
Specifications 195
 VK401 195
 VK430 195
 VR610 197
Technical Support 199
 International 199
 North America 199
ATEN Warranty Policy 200

About this Manual

This user manual is provided to help you get the most out of your ATEN Room Booking System. It covers all aspects of the system, including installation and operation of RBS equipment (as listed below) and interface configuration using RBS Configurator. Devices and software covered in this manual include:

Models	Product Names
VK401	Access Inspector
VK430	10.1" Room Booking System (RBS) Panel
VR610	infoPlayer
RBS Configurator	Room Booking System (RBS) Configurator

An overview of the information found in the manual is provided below.

Chapter 1, Introduction

Introduces you to ATEN Room Booking System, its purpose, features, and components.

Chapter 2, Hardware Setup

Provides a hardware overview of ATEN RBS equipment, and the necessary steps to set up the equipment.

Chapter 3, Configuring RBS Profiles

Provides installation instructions of the ATEN RBS Configurator, an overview of the interface, and detailed information on the available functions.

Chapter 4, Calendar Server

Guides you through the implementation of your ATEN Room Booking System to calendar servers, such as Microsoft 365 Calendar, Microsoft Exchange, and Google Workspace for convenient scheduling management of all conference rooms in the system.

Chapter 5, infoPlayer and RBS Panel Operation

Guides you through the operations that can be done on infoPlayer-connected display and ATEN RBS Panels, such as viewing schedules, booking or checking into rooms, and canceling meetings.

Chapter 6, Device Management

Provides information on how to remotely perform management tasks such as switching profiles, upgrading device firmware, configuring system & network settings.

Appendix

Provides specifications and other technical information regarding the ATEN Room Booking System.

Note:

- ◆ Read this manual thoroughly and follow the installation and operation procedures carefully to prevent any damage to the unit or connected devices.
 - ◆ ATEN regularly updates its product documentation for new features and fixes. For an up-to-date ATEN RBS documentation, visit <http://www.aten.com/global/en/>
-

Conventions

This manual uses the following conventions:

- | | |
|---|--|
| Monospaced | Indicates text that you should key in. |
| [] | Indicates keys you should press. For example, [Enter] means to press the Enter key. If keys need to be chorded, they appear together in the same bracket with a plus sign between them: [Ctrl+Alt]. |
| 1. | Numbered lists represent procedures with sequential steps. |
| ◆ | Bullet lists provide information, but do not involve sequential steps. |
| > | Indicates consecutive selecting options (such as on a menu or dialog box). For example, Start > Run means to open the <i>Start</i> menu, and then select <i>Run</i> . |
|  | Indicates critical information. |

This Page Intentionally Left Blank

Chapter 1

Introduction

Overview

Room Booking System and RBS Panels

The ATEN Room Booking System is an Ethernet-based room management system that works in conjunction with a calendar server, such as Microsoft 365 Calendar, Microsoft Exchange, Google Workspace, DingTalk, and ATEN Unizon Timetable to provide convenient scheduling, availability allocation, reservation, and status indication for all of the rooms managed in your organization.

ATEN Room Booking System consists of VK430 RBS Panels, 1 for each room managed, and an RBS Configurator used to configure the RBS Panels and calendar server.

Through ATEN Room Booking System, users can check for the availability of every room, book the desired rooms while scheduling meetings, as well as cancel or extend their room booking.

On each VK430 RBS Panel, you can check the time slots the corresponding room is available for and reserve immediately or for a desired time with a few simple taps.

Using RBS Configurator, the administrator can adjust the theme style and setting profiles of each VK430 RBS Panel.

The ATEN Room Booking System is the perfect solution for any meeting and conference room, boardroom, classroom, and any other room booking management through streamlined Ethernet-based management system in conjunction with a calendar server for optimum efficiency and performance.

ATEN Access Inspector (VK401)

As an add-on accessory designed to complement ATEN 's touch panel series (VK430 10.1" RBS Panel and VK330 10.1" Touch Panel), the VK401 Access Inspector enhances security and prevents unauthorized usage for credential-based applications. Operating at a frequency 13.56 MHz, this compact access

control unit supports multiple standards such as ISO 14443A/B and ISO 15693 and reads smart cards including Mifare and Felica.

When user profiles are being created by administrators on ATEN Unizon, the data will be used as a basis to authenticate users scanning cards via the VK401 attached to the VK430 / VK330, and thereby allow authorized personnel to check in. In addition, the authorized users are allowed to lock / unlock meeting rooms and facilitate conference room automation solutions when the space management ecosystem is integrated with the VK control system. Meanwhile, the VK401 helps the collection of valuable data, including meeting attendance list and meeting duration. Consequently, meeting records can be tracked for centralized management, and the reports can be sent to designated users on a daily / weekly / monthly / quarterly basis, elevating overall operational efficiency.

The VK401 is a critical role in maintaining high levels of security and hygiene and operational excellence when it comes to meeting room management solutions in a post-pandemic era where contactless access control is in essential. It also serves as an extension of the existing access control system to your meeting room management to complete the security coverage.

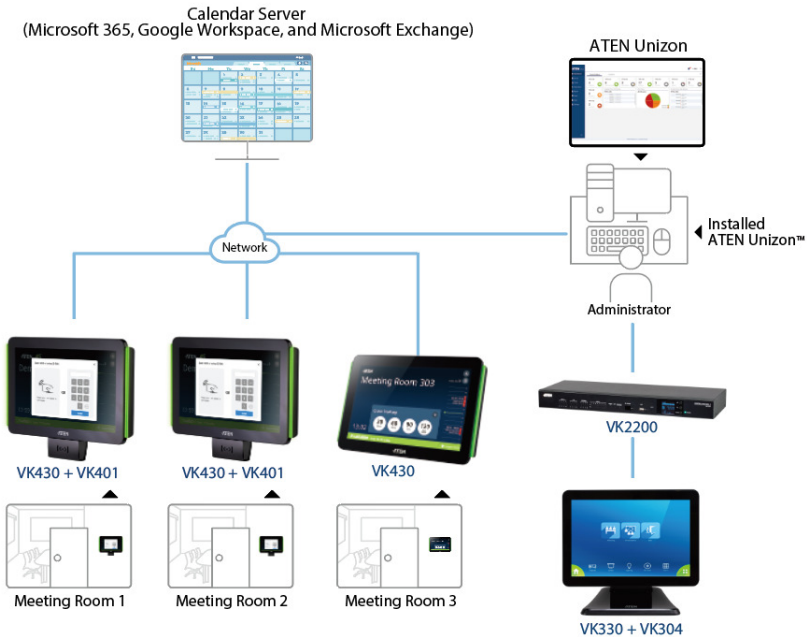

ATEN infoPlayer (VR610)

The ATEN VR610 infoPlayer is a network device that pulls in room availability information and displays the information through a connected touch or non-touch display for room booking. Room status information can be easily switched between list view or map view on the display device.

On top of room availability, infoPlayer can also display news and announcements in the form of text, videos, images, or web pages.

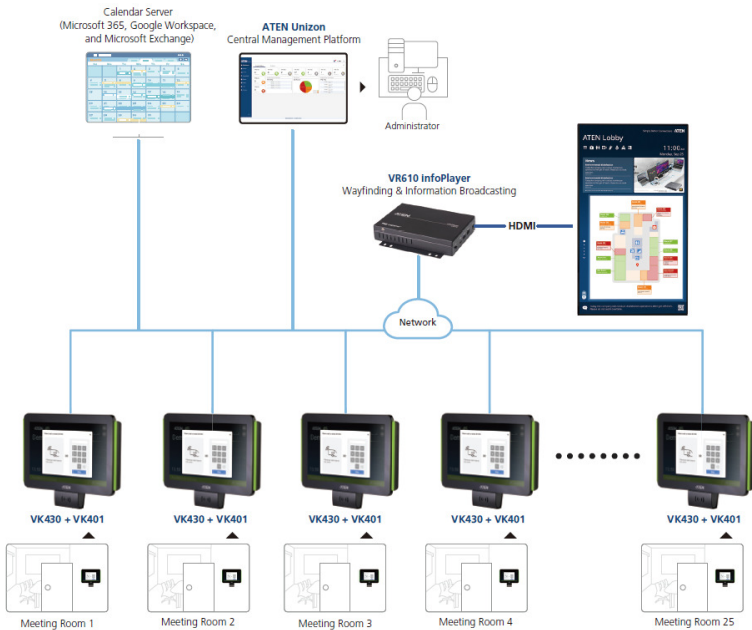

Features

RBS Configurator

- ◆ Easy configuration via intuitive GUI
 - ◆ Profile setup (logo, background, calendar layout, etc.)
 - ◆ System settings (language, sleep mode, brightness, volume, etc.)
 - ◆ VK430 RBS Panels and VR610 RBS infoPlayer management (firmware updates and profile uploads, etc.)
- ◆ Simulator to simulate and preview the customized GUI before uploading
- ◆ Flexible booking options for different application scenarios and user preferences
- ◆ Flexible choose identity checkup methods by PIN code or employee card
- ◆ Supports mainstream calendar servers, including Microsoft 365 Calendar and Google Workspace Calendar, Microsoft Exchange Server, DingTalk, and ATEN Unizon Timetable

ATEN Access Inspector (VK401)

- ◆ An add-on compact accessory that works with ATEN VK430 10.1” RBS Panel and VK330 10.1” Touch Panel
- ◆ Operates at 13.56 MHz
- ◆ Supports multiple standards — ISO 14443A/B and ISO 15693
- ◆ Reads smart cards — Mifare and Felica
- ◆ Contactless access control with high levels of security and hygiene
 - ◆ Only authorized users can scan cards to book, check in, lock, or unlock meeting rooms and facilitate conference room automation
 - ◆ Helps collect valuable data, including meeting attendance list and meeting duration
 - ◆ Keeps track of meeting records for centralized management
 - ◆ Reports can be sent to designated users regularly on a daily, weekly, monthly, or quarterly basis

Note: This is only available and configured through ATEN Unizon.
For more information, see *ATEN Unizon User Manual*.

VK430 10.1” RBS Panel

- ◆ 10.1” capacitive touch-screen panel
- ◆ Supports integration with calendar servers, such as Microsoft 365 Calendar, Google Workspace Calendar, Microsoft Exchange Server, DingTalk, and ATEN Unizon Timetable
- ◆ Supports RBS Configurator for batch upgrade, customizable booking options, and calendar settings.
- ◆ Works with a VR610 RBS infoPlayer to provide users a glimpse of room status and floor plan through the VR610-connected display
- ◆ In conjunction with the VK401, the system enables exclusive card-access functionality; only authorized users can scan cards to book and check in meeting rooms and facilitate conference room automation
- ◆ Supports central management through ATEN Unizon to allow administrators to monitor managed devices in real time, generate room usage analyses, and update app in batch
- ◆ Supports TCP for third-party system integration
- ◆ Supports Power over Ethernet (PoE), which allows the RBS panel to receive power and communication over a single Ethernet cable
- ◆ LED light bars illuminating user-defined colors to indicate the room’s availability at a glance
- ◆ Pre-installed with a wall mount kit and provided with 3M VHB™ Tape for easy mounting onto a hard or glass wall
- ◆ 75*75 mm VESA-compliant for flexible mounting across various installation scenarios
- ◆ TCP CLI compliant

Note:

- ◆ To manage RBS panels using ATEN Unizon™, make sure to update the RBS App to v1.3.123 or later.
 - ◆ To use VK401 Access Inspector, make sure to update/upgrade RBS Configurator and RBS app (installed on RBS panels) to v1.6 or later.
 - ◆ To use VR610 infoPlayer, make sure to update/upgrade RBS Configurator and RBS app (installed on RBS panels) to v1.7 or later.
 - ◆ For more information on ATEN Unizon™, refer to *ATEN Unizon™ User Manual*.
-

ATEN infoPlayer (VR610)

- ◆ Centrally displays room availability and news/announcements on a connected HDMI display
- ◆ Supports two view types for displaying room booking status:
 - ◆ List View: displays reservation details in an easy-to-read list
 - ◆ Map View: displays reservation details on an uploaded map to help users navigate through the spaces intuitively
- ◆ Supports customization of display content (logos, text, images, videos, web pages, and screen layouts) via RBS Configurator or remotely via VR610's HDMI-in signals
- ◆ Supports touchscreen operation (e.g. quick booking or reservation checks) via the built-in USB-C or USB Type-A ports
- ◆ Equipped with dual CPUs – performs multiple tasks simultaneously, including inter-communication with RBS Configurator and RBS Panels and displaying room booking status and multimedia sources
- ◆ 4K crystal-clear clarity – gives a vivid, unambiguous display of the content
- ◆ Power over Ethernet (PoE) – VR610 receives power and data via an Ethernet cable
- ◆ Detachable bracket guarantees flexible mounting to the back of a monitor

Requirements

Prepare the following equipment and make sure your equipment meets the minimum requirements specified below.

- ◆ **Rooms to be managed by your ATEN Room Booking System, with the following equipment**
 - ◆ 1 VK430 ATEN 10.1" RBS Panel per room
 - ◆ 1 available PoE+ port per room, from a PoE switch / injector or 1 power adapter (available for purchase, see *Accessories*, page 12)
- ◆ **A computer (for running ATEN RBS Configurator), with the following spec**
 - ◆ OS: Windows 7 / 8 / 10 (32/64-bit)
 - ◆ Processor: 1 GHz
 - ◆ Memory: 1 GB RAM
 - ◆ Storage: 500 MB available hard disk space

Getting Started

Setting Up ATEN RBS Panels and Calendar Servers

Complete the following tasks to start setting up your ATEN Room Booking System and managing your room resources.

No.	Getting Started Tasks	Detailed Procedure
Hardware Install		
1	Install an ATEN RBS Panel to each of the room to be managed by your ATEN Room Booking System.	<i>Installing an RBS Panel</i> , page 18
Software Install		
2	Install the configuration tool, ATEN RBS Configurator to a computer that has network access to the installed RBS panel(s).	<i>Installing/Updating RBS Configurator</i> , page 23
Panel Interface & Calendar Server Configuration		
3	Define a desired layout and theme style for the installed ATEN RBS Panels.	<i>RBS Panel Profiles</i> , page 47
4	By default, the RBS panel is DHCP-enabled. Configure the network settings if needed.	<i>Configuring Network Settings</i> , page 153
5	Set up the calendar server for ATEN Room Booking System.	Chapter 4, <i>Calendar Server</i>
6	Upload the configured profiles and settings to the ATEN RBS Panels.	<i>Uploading Profiles to infoPlayer/RBS Panels</i> , page 169

Setting Up the infoPlayer

Follow the steps below to set up your infoPlayer.

No.	Getting Started Tasks	Detailed Procedure
Preparation		
1	Make sure to upgrade the installed RBS panels to firmware v.1.11.18e or later. and their RBS app to v1.7 or later.	<i>Upgrading the RBS Panel Firmware, page 173</i> in this user manual
2.	Make sure to update RBS Configurator to v.1.7 or later.	<i>Installing/Updating RBS Configurator, page 23</i>
Hardware Install		
3	Install the infoPlayer and a display monitor.	<i>Installing the infoPlayer, page 21</i>
Display Layout Configuration		
4	Design and configure a profile (display layout) for the infoPlayer display.	<i>Configuring RBS Profiles, page 23</i>
5	Add RBS panels to the infoPlayer.	
6	Upload the configured profile to infoPlayer.	<i>Uploading Profiles to infoPlayer/RBS Panels, page 169</i>

Setting Up Access Inspector

Complete the following tasks to start setting up your Access Inspector (VK401) to your ATEN Room Booking System.

No.	Getting Started Tasks	Detailed Procedure
<i>Preparation</i>		
1	Make sure you have set up ATEN Unizon and added RBS panels into the Unizon platform.	<i>ATEN Unizon User Manual</i>
2	Make sure the following systems and devices have been updated to a supported version.	-
	♦ RBS panel firmware (v1.11.17k or later)	<i>Upgrading the RBS Panel Firmware, page 173 in this user manual</i>
	♦ RBS panel app (v1.6.152 or later)	<i>Updating the RBS Panel App, page 178 in this user manual</i>
	♦ RBS Configurator (v1.6 or later)	<i>Installing/Updating RBS Configurator, page 23</i>
	♦ ATEN Touch Panel firmware (v.1.1.17n or later)	<i>Chapter 2 Hardware Setup, ATEN Control System User Manual</i>
	♦ ATEN Touch Panel app (v.3.7.362 or later)	
	♦ ATEN Unizon (v2.4 or later)	<i>ATEN Unizon User Manual</i>
	♦ ATEN Control System (v3.7 or later)	<i>ATEN Control System User Manual</i>
<i>Hardware Install</i>		
3	Install RBS panels.	<i>Installing an RBS Panel, page 18</i>
4	To rooms that require access inspection via access cards , install an Access Inspector to each RBS panel of these rooms.	<i>Installing an Access Inspector to an RBS Panel, page 14</i>
<i>System Configuration</i>		
5	On ATEN Unizon, add users and groups.	<i>ATEN Unizon User Manual</i>

No.	Getting Started Tasks	Detailed Procedure
6	In RBS Configurator, configure the following settings for each room. <ul style="list-style-type: none">◆ Select a method for identity inspection◆ Configure check-in privilege◆ Enable or disable sign-on notification	<i>Device Configuration Options, page 164.</i>
7	Upload the configured profile to RBS panels.	<i>Uploading Profiles to infoPlayer/RBS Panels, page 169</i>

Accessories

Optionally purchase any compatible power adapter and/or power cord if needed, as listed below. Contact your ATEN dealer for detail.

Model	Description	Region
0AD8-8012-33MG	power adapter	all
LIN2-418K-D12G	power cord	A
LIN2-418K-E12G	power cord	E
LIN2-418K-D16G	power cord	J
LIN2-418K-F11G	power cord	U
LIN2-418K-N12G	power cord	I
LIN2-418K-G11G	power cord	G
LIN2-418K-Z11G	power cord	Z
LIN2-418K-K11G	power cord	K

Chapter 2

Hardware Setup



Important safety information regarding the placement of this device is provided on *Safety Instructions*, page 191. Please review it before proceeding.

This chapter guides you through the hardware setup of ATEN RBS device as well as cover some of its basic configurations.

ATEN Access Inspector

Components

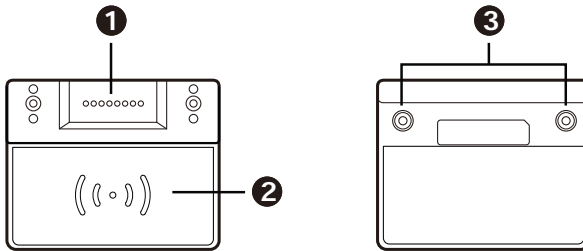

No.	Component	Description
1	contact pins	The contact pins transmit detected data to an RBS panel.
2	detection area	Detects access cards.
3	screw holes	Use these screw holes and the provided screws to secure an Access Inspector to an RBS panel.

Installing an Access Inspector to an RBS Panel

Make sure that you power off the RBS Panel and disconnect it from the power source before installing the Access Inspector.

1. Attach the VK401 Access Inspector to the VK430 RBS Panel with the VK401's contact pins facing the contact pins of VK430 RBS Panel.

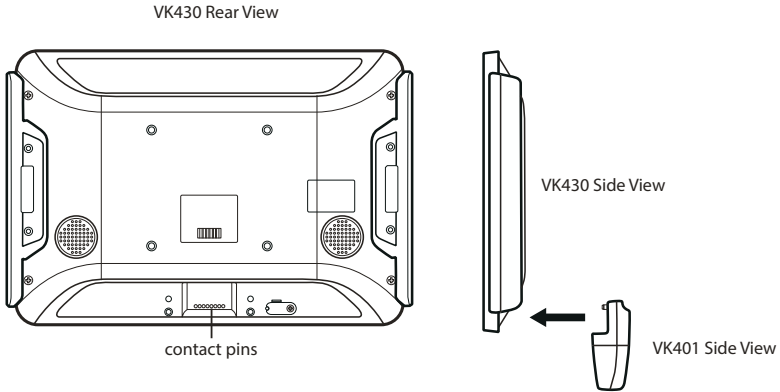

2. Fasten the VK401 to the VK430 using the 2 supplied screws.

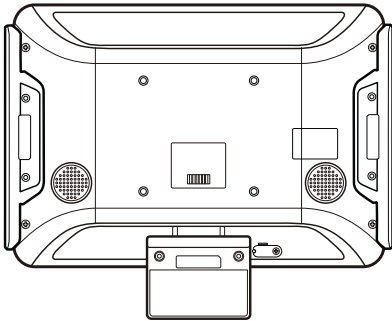

3. Connect the VK430 RBS Panel to the power source and then switch its power switch to turn it on.

Obtaining Card Numbers

To find out a card number, as detected by ATEN Access Inspector or to test if a pre-existing card is supported by ATEN Access Inspector, use the Test Card function.

1. Make sure you have installed at least one RBS panel with an Access Inspector. For details, see *Installing an Access Inspector to an RBS Panel*, page 14.
2. On the RBS panel, tap  and enter the administrator password to log in.
3. Tap **Test Card** from the left panel. This screen appears.

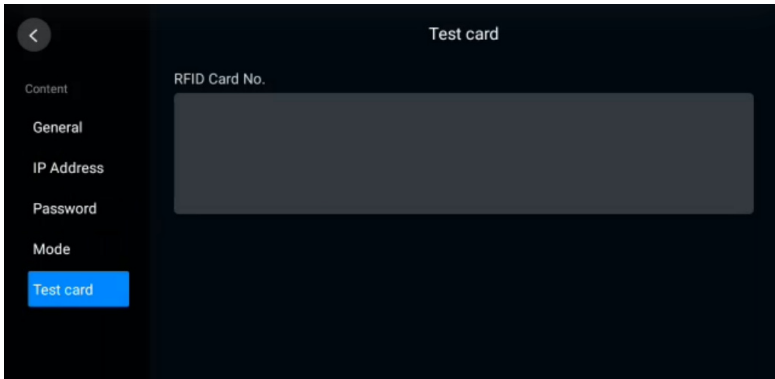

4. Scan an access card on the Access Inspector. If a series of numbers appears, the card is supported by ATEN Access Inspector.

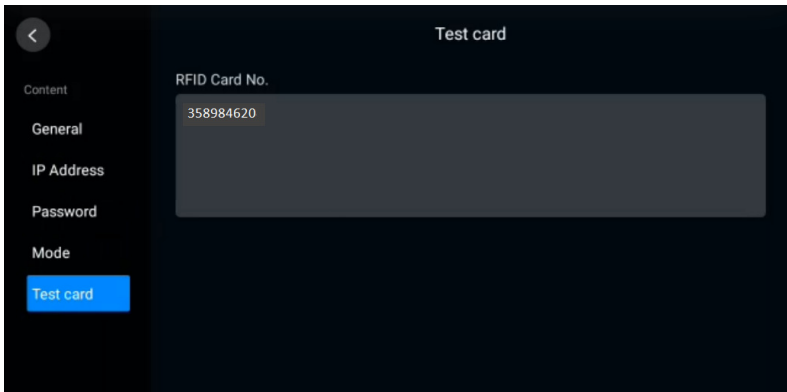

ATEN RBS Panel

Components

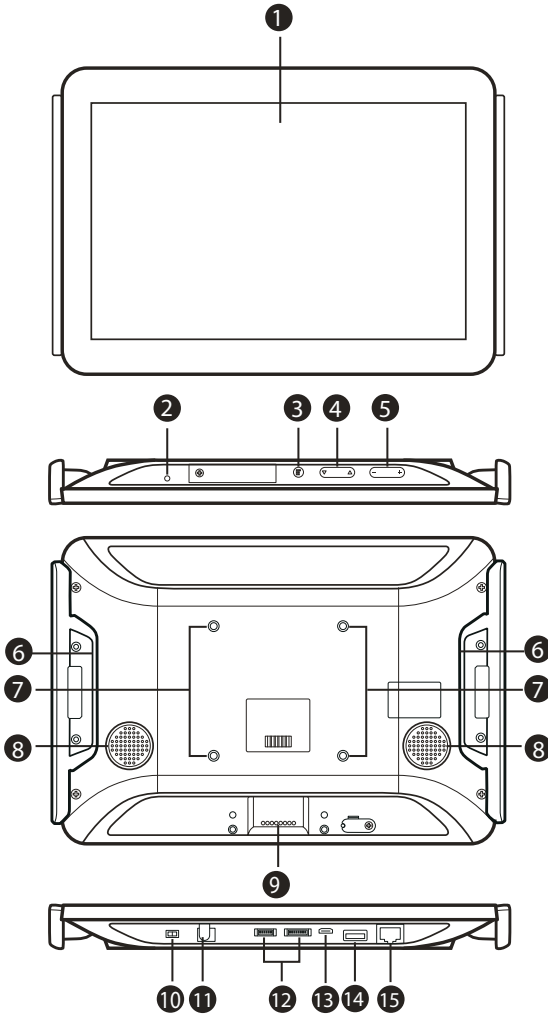

No.	Component	Description
1	touch screen	Tap to configure or reserve the corresponding room.
2	status LED	Lights on when the touch panel is powered on.
3	function button	Press to access the <i>Settings</i> page.
4	brightness + / -	Press to adjust the display brightness.
5	volume + / -	Press to adjust the volume of the touch panel.
6	stereo audio out	Connects to a stereo audio output.
7	screw holes for panel plate	Used to secure the panel plate.
8	speakers	Plays beep sounds to indicate operation actions.
9	contact pins	Connect to an Access Inspector to receive and transmit data.
10	power switch	Turns the touch panel on or off.
11	power jack	Connects to power.
12	reserved for debugging purposes	These ports are reserved for debugging.
13	USB Micro-B port	Reserved for debugging.
14	USB type-A port	Used to update the ATEN RBS app and/or firmware.
15	LAN port with PoE	Connects to the network, while receiving power via PoE.

Installing an RBS Panel

The ATEN VK430 RBS Panel comes pre-installed with two light bars. The RBS panel is also compatible with any VESA-compliant (75 x 75 mm) mounting accessory. Follow the steps below to install and mount the VK430 onto a wall.

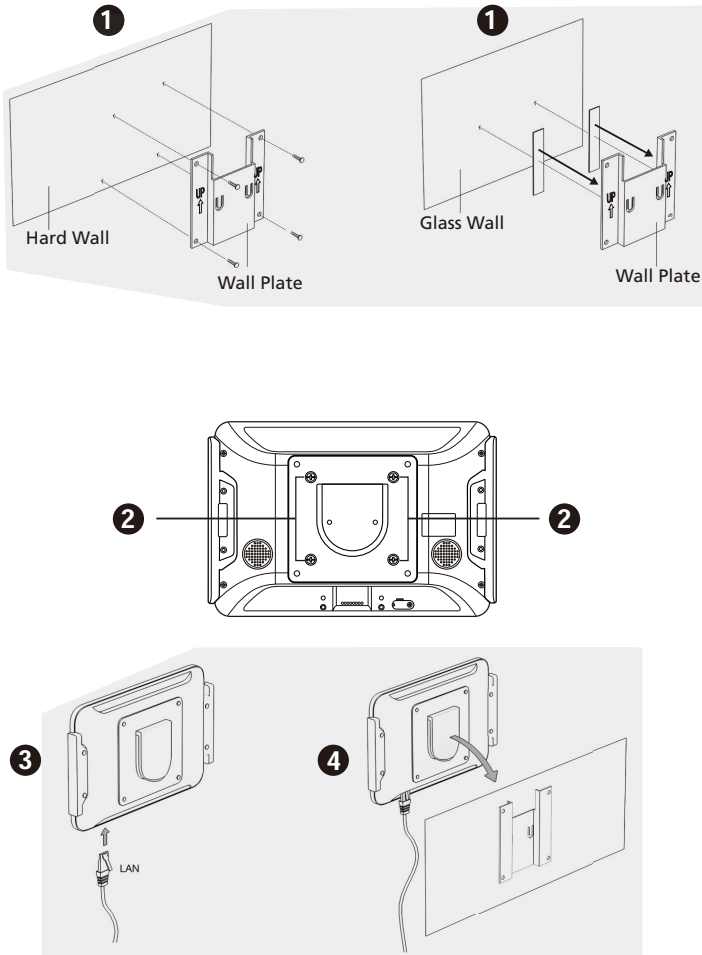

1. Secure the wall plate onto a (a) hard or (b) glass wall.

- ◆ *Hard Wall*: Using the 4 screws provided (also use the 4 screw anchors if necessary), secure the wall plate onto the hard wall with the arrows on the plate pointing upward.
- ◆ *Glass Wall*: Stick the 2 strips of tape provided to the back of the wall plate, and then press the wall plate onto the glass wall, with the arrows on the plate pointing upward.

IMPORTANT: For optimal adhesive results, make sure to firmly press the taped mounting plate against the wall for 3 ~ 5 seconds and wait for it to dry for at least 24 hours.

2. Secure the provided panel plate to the back of the RBS panel using the short screws provided.
3. Using the 90° RJ-45 cable adapter provided and an Ethernet cable, connect the RBS panel to a PoE switch / injector to provide power and access to network.

Note: Make sure that the RBS panel receives adequate power supply (DC12V, 17.8W, 60.70BTU or PoE 20W, 68.24BTU). With inadequate power supply, processes such as firmware updates and app updates may fail.

4. Place the RBS panel onto the wall by sliding and attaching it to the wall plate.
5. Turn on the RBS panel by switching its power switch to **ON**.

Upon first-time startup, the VK430 shall be offline and not connected to any calendar server.

To set up the VK430, you shall use the ATEN RBS Configurator software to create the necessary setting profiles to be uploaded to it. See *Configuring RBS Profiles*, page 23.

ATEN infoPlayer

Components

Left Panel View

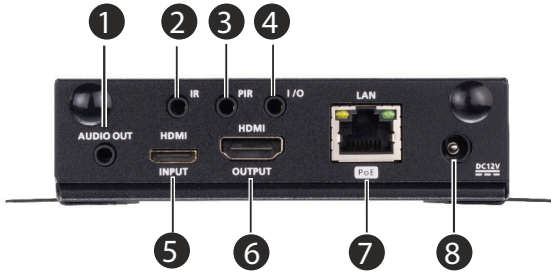

Right Panel View

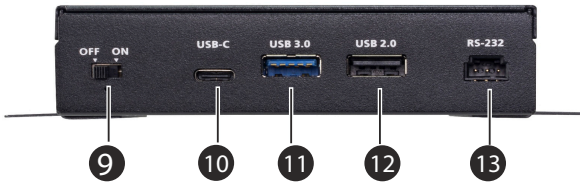

No.	Component	Description
1	audio out	<i>Reserved for future development</i>
2	IR	<i>Reserved for future development</i>
3	PIR	Receives PIR cable for motion detection to increase benefit of advertisement on our spotlight mode feature. If no movement is detected by the PIR sensor, widget will be enlarged for users. To set widget, please see page 33 for more information. Note: PIR supports up to distance 1.5 m and angle of 90 degrees.
4	I/O	<i>Reserved for future development</i>

No.	Component	Description
5	HDMI in	Receives HDMI content from a multimedia player.
6	HDMI out	Connects to a touch/non-touch panel to display the configured content. The system supports a 4K 60 Hz display, with a color depth of 8 bit.
7	Ethernet/PoE	Connects the infoPlayer to the network or to a PoE switch / injector to receive power and access to the network.
8	power	Reserved for future development.
9	power switch	Switches the unit on/off. Use the LED below the switch to find out the power status of the device. <ul style="list-style-type: none"> ◆ Off: The device is powered off. ◆ On (green): The unit is powered on and ready. ◆ On (orange): The unit is powered on and just started.
10	USB-C	Connect to USB peripherals such as a wired keyboard, mouse, and/or touch display. Compatibility of wireless keyboard and mouse may vary depending on the brands and models.
11	USB 3.0	
12	USB 2.0	
13	RS-232 serial port	<i>Reserved for future development</i>

Installing the infoPlayer

1. Connect a touch/non-touch display to the HDMI out port on the infoPlayer.

Note: To replug the HDMI cable, the system will take about 30 seconds for any widget video to resume on the infoPlayer display.

2. Connect a touch or non-touch display to the infoPlayer.
 - ◆ To use a touch display, connect the display to the USB port of the infoPlayer.
 - ◆ To use a non-touch display, connect a keyboard and a mouse to USB ports for operation.
3. Connect the LAN port of the infoPlayer to a PoE switch/injector using an Ethernet cable for network access and power supply.
4. Put the power switch to **ON**.

This Page Intentionally Left Blank

Chapter 3

Configuring RBS Profiles

The ATEN RBS Configurator is a GUI-based management software that helps you configure control interface on RBS panels and infoPlayer displays for convenient management of your conference room resources against a calendar server, including Microsoft 365 Calendar, Microsoft Exchange, Google Workspace, DingTalk, and ATEN Unizon Timetable.

Installing/Updating RBS Configurator

Install RBS Configurator to a computer or laptop that has network access to your Room Booking System and its installed hardware devices. To install or update the RBS Configurator software, do the following:

1. Download RBS Configurator.
 - a) Visit the ATEN download page.
<http://www.aten.com/global/en/support-and-downloads/downloads/>
 - b) Search for “RBS Configurator.” A list of downloads for RBS Configurator appears.
 - c) Download **RBS_Configurator_Setup_vx.x.xxx.exe**.

- Execute the setup file. Then follow the on-screen instructions to install the RBS Configurator.

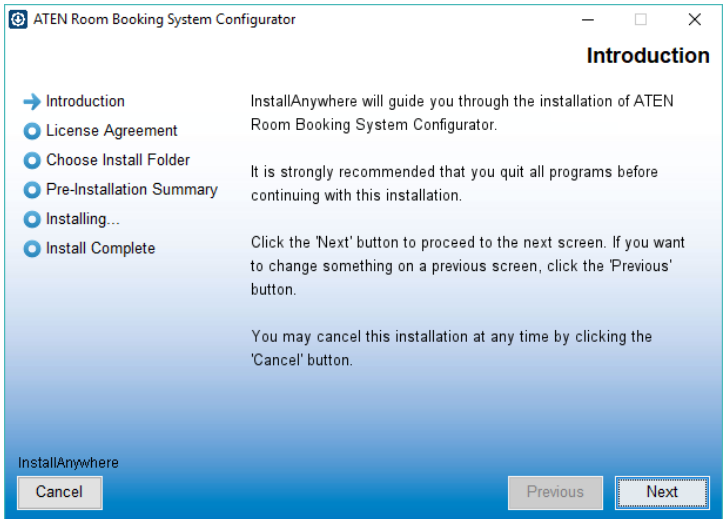

Note: On the *License Agreement* page, thoroughly read through and accept the terms of the license agreement before proceeding.

- Once the installation is completed, click **Done** to finish.

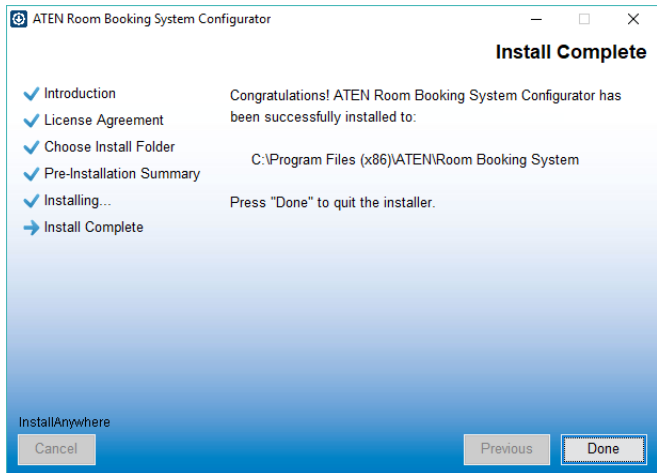

The Main Screen of RBS Configurator

Launch the software to start configuring your ATEN Room Booking System. Below is the general interface of RBS Configurator and its components.

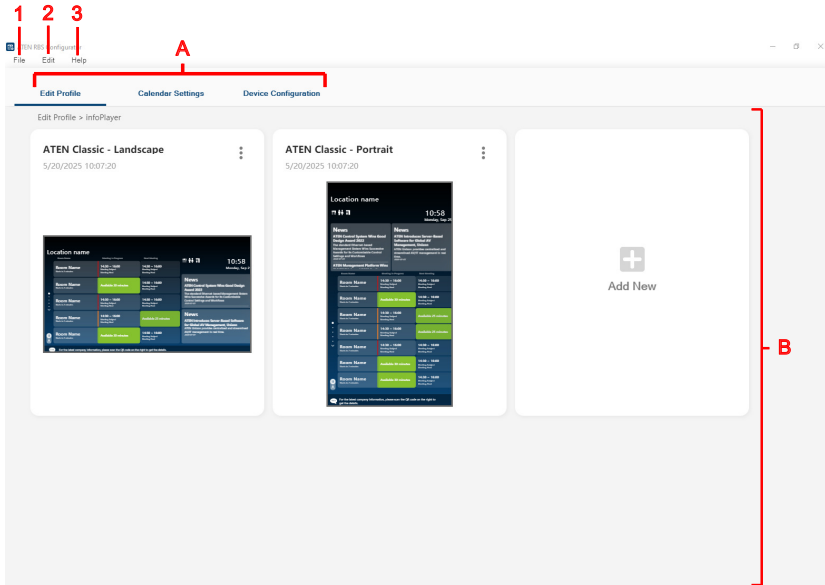

No.	Item	Description
A	Tab Menu	<p>Use the tab menu to switch views between the following:</p> <ul style="list-style-type: none"> ◆ Edit Profile: Defines layout designs to be used on RBS panels (in meeting rooms) or infoPlayer (in lobby rooms). Click to select Lobby Viewer Profile or Room Panel Profile to add or edit profiles. <ul style="list-style-type: none"> ◆ For more details about Lobby Viewer Profile, see <i>infoPlayer Profiles</i>, page 27. ◆ For more details about Room Panel Profile, see <i>RBS Panel Profiles</i>, page 47. ◆ Calendar Settings: Contains the required calendar server settings for integration with ATEN Room Booking System. For more details about Calendar Settings, see Chapter 4, Calendar Server, page 57. ◆ Device Configuration: Upload and/or edit profiles to ATEN RBS Panels or infoPlayer display via network. For more details about Device Configuration, see Chapter 6, Device Management, page 163.

No.	Item	Description
B	Interactive Display	This section is your main work area, which reflects the tab menu item selected.
1	File	<ul style="list-style-type: none"> ◆ New Project: Clears the current project and start a new one. ◆ Open Project: Opens a previously-saved project file. ◆ Save: Saves the current project. ◆ Save as: Saves the current project as a new project file. ◆ Exit: Exits and closes RBS Configurator.
2	Edit	<ul style="list-style-type: none"> ◆ Language: Changes the <i>language</i> of the RBS Configurator. English, Traditional Chinese, Simplified Chinese, Japanese, Korean, Russian, French, Spanish, Polish, Hungarian, Portuguese, Arabic, Icelandic, Thai, and Dutch.
3	Help	<ul style="list-style-type: none"> ◆ About: Displays the information of the RBS Configurator.

infoPlayer Profiles

Adding a new infoPlayer Profile

1. In RBS Configurator, click **Edit Profile** and select **Lobby Viewer Profile**. This screen appears.

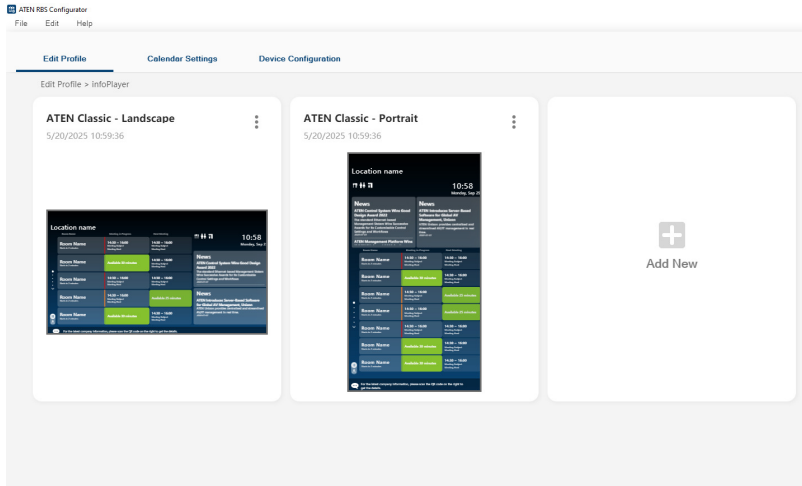

2. Click **Add New**. This dialog box appears.

The screenshot shows a dialog box titled 'Create New Profile'. The dialog box has a dark blue header with the title. Below the header, there is a text input field labeled 'Profile Name'. At the bottom of the dialog box, there are two buttons: a grey 'Cancel' button and a green 'Create' button.

3. In the pop-up dialog box, name the profile and click **Create**. An infoPlayer profile is created.

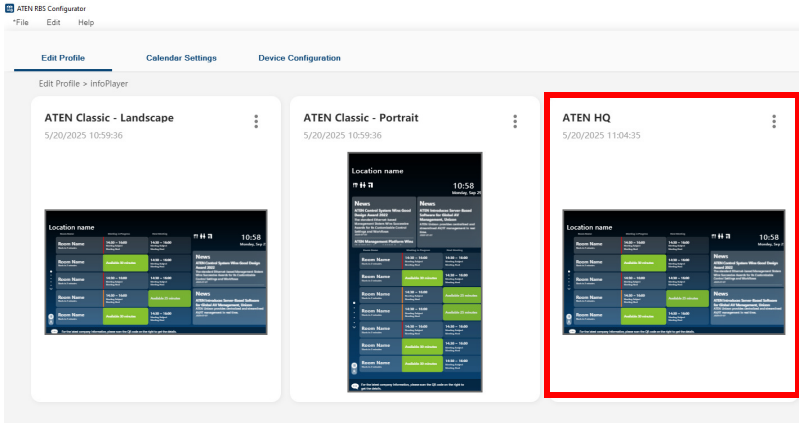

Configuring infoPlayer Profiles

Configuration Panel Overview

To open the configuration panel of an infoPlayer profile, go to **Edit Profile > Lobby Viewer Profile**, and then click on a desired profile to start. The following page appears.

The screenshot displays the configuration panel for an ATEN Classic - Portrait infoPlayer profile. The interface is split into two main parts:

- Preview Area (A):** Shows a mobile device screen with the following content:
 - Location name
 - Icons for accessibility (wheelchair, stroller, baby carriage)
 - Time: 10:58
 - Date: Monday, Sep 25
 - News section with three articles.
 - Meeting schedule table:
- Settings Area (C):** Contains configuration options:
 - GUI Design:** Includes a 'List view' dropdown.
 - Booking Settings:**
 - Panel Settings:**
 - Display Orientation: Portrait
 - View Mode: Both (List & Map)
 - Default View Mode: List View (selected), Map View
 - Is the connected display touch-sensitive?: Yes
 - Date and Time:**
 - Date Format: Sep 25
 - Time Format: 24-Hour Time
 - Time: 23:59
 - Brand/Logo Upload:**
 - Company Logo (.jpg, and .png only): Select file button
 - Slogan: Text input field
 - Text:** Cancel and Save buttons.

There are three main parts to the configuration panel. Refer to the table below for available settings and their function descriptions.

No.	Item	Description
A	Profile Preview	Displays a preview of how the infoPlayer-connected display would look once the profile is applied.
B	View Mode	<ul style="list-style-type: none"> ◆ Click to switch the view mode between list view (default) and map view. ◆ To edit the map, set the mode to Map View and then click on the Edit Map button. For more details about configuring the map, see <i>Configuring a Map</i>, page 40. For more details on the map size, see <i>Map & Widget Size</i>, page 44.
C	Interface and Booking Settings	<p>Contains the following:</p> <ul style="list-style-type: none"> ◆ GUI Design: Defines the profile's layout, information content, and visual related settings. For more details, see <i>GUI Design</i>, page 31. ◆ Booking Settings: Sets the profile's booking-related settings. For more details, see <i>Booking Settings</i>, page 36.

Configuring the infoPlayer Display Settings

1. In RBS Configurator, go to **Edit Profile > Lobby Viewer Profile**.
2. Click on your target profile. The configuration panel appears.
3. Configure the GUI design and/or booking settings as needed.

■ GUI Design

Item	Sub-Item	Description
Panel Settings	Display Orientation	Based on how your infoPlayer display is installed, select one of the following options for the system to provide an output that fits. <ul style="list-style-type: none"> ◆ Portrait: A portrait orientation shows content with great height than width in the displayed area. ◆ Landscape: A landscape orientation shows content with great width than height in the displayed area.
	View Mode	Sets the view modes available for switching on the infoPlayer display. <ul style="list-style-type: none"> ◆ List view: In list view, room status is shown in a list. Select this option to only show room status in list view. ◆ Map view: In map view, room status is shown on an uploaded floor plan. Select this option to only show room status in map view. ◆ Both (List & Map): Select this option to make list view and map view available for switching on the infoPlayer display.
	Default View Mode	Sets the default view mode for the profile.
	Is the connected display touch-sensitive?	If the connected display is touch-sensitive, select Yes . This allows the users to tap on the display for more room / meeting details and other instructions.
Date and Time	Date Format	Sets the format in which date is displayed on the infoPlayer display.
	Time Format	Sets the format in which time is displayed on the infoPlayer display.

Item	Sub-Item	Description
Brand/Logo Upload	Company Logo	Uploads a brand logo image (.jpg, or .png), up to 60*624 pixels, to be displayed on the upper-right of the infoPlayer display.
	Slogan	Type in a corporate slogan to show on the infoPlayer display.
Text	Text Size	Sets the text size between default and large for the infoPlayer display.
Background	Main Page	Defines the background of the infoPlayer display's main page by selecting a color from the color palette.
	Sub Page	Sets the display color of the infoPlayer display's sub page.
Status Color	Available	Sets the color indication of currently available rooms on the infoPlayer display.
	Reserved	Sets the color indication of currently reserved rooms on the infoPlayer display.
	Occupied	Sets the color indication of currently occupied rooms on the infoPlayer display.
Announcements	Content	Type to show announcements.
	QR code or icon	Upload a QR code. It may be a registration form, or any supplementary information to be provided for the viewer of the infoPlayer display.
Facility Signs	Enable	Open or hide the display of facility signs.

Item	Sub-Item	Description
Widgets		<p>Defines the number and type of widgets to be shown on the infoPlayer display. For each added widget, define the type (news, media, URL, RSS) and configure the sub-settings. For more details on the widget size, see <i>Map & Widget Size</i>, page 44.</p> <ul style="list-style-type: none"> ◆ news: Click Edit to add the title, content, and date of the news. ◆ media (pictures or videos): <ul style="list-style-type: none"> ◆ Configure the proportion and source of the media. ◆ Video requirements: <ul style="list-style-type: none"> ◆ The video needs to be of H.264 and in .mov, .mkv, or .mp4 format. ◆ If the video is sent through PC, make sure the size of the widget(s) does not exceed 400 MB in total, and that the profile size does not exceed 450 MB. ◆ Image requirements: <ul style="list-style-type: none"> ◆ Make sure the image is of .jpg, .png, or .webp format. ◆ If the image is sent through PC, make sure the size of the widget(s) does not exceed 400 MB in total, and that the profile size does not exceed 450 MB. ◆ Note: <ol style="list-style-type: none"> 1. The video or image may change in size depending on the resolution of the connected display and the number of widgets included to the profile. For a list of supported map and widget size between 1080p and 4K displays, see <i>Map & Widget Size</i>, page 44. 2. Please note that when using a media widget from HDMI input port, a certain degree of latency may occur due to video processing. For a list of supported EDID resolution, see <i>Supported HDMI In Resolutions</i>, page 46. 3. When access files via USB port is selected, any media files stored in the root directory of a USB drive will play sequentially. The USB drive supports NTFS, exFAT, and FAT32 file systems.

Item	Sub-Item	Description
		<p>4. The maximum supported video file resolution varies depending on how many widget and the source input is selected. For more details on the recommended resolution, see <i>Supported Widget Resolution from Different Input Source</i>, page 46.</p> <p>5. If the HDMI input source is hot-plugging, which means the input source was removed and added back into the unit without shutting the unit down, it takes approximately 30 seconds to show display.</p> <ul style="list-style-type: none"> ◆ URL: Enter an web URL in the Input URL field. ◆ RSS: Select Rss and click Edit. From the pop-up window, follow the on-screen instruction to copy and paste the RSS feed (URLs) to the pop-up window box.
Spotlight Mode	Enable	Enable or disable the spotlight mode.
	Show Spotlight Mode After	Sets up a movement detection time limit for the spotlight mode to appear when there is no human movement detected in the specified time limit.

Item	Sub-Item	Description
	Widget	<p>Defines the type of widget to be shown on the infoPlayer display when the spotlight mode is enabled. For the added widget, define the type (media, URL, RSS) and configure the sub-settings. For more details on the widget size, see <i>Map & Widget Size</i>, page 44.</p> <ul style="list-style-type: none"> ◆ media (pictures or videos): <ul style="list-style-type: none"> ◆ Configure the proportion and source of the media. ◆ Video requirements: <ul style="list-style-type: none"> ◆ The video needs to be of H.264 and in .mov, .mkv, or .mp4 format. ◆ If the video is sent through PC, make sure the size of the widget(s) does not exceed 400 MB in total, and that the profile size does not exceed 450 MB. ◆ Image requirements: <ul style="list-style-type: none"> ◆ Make sure the image is of .jpg, .png, or .webp format. ◆ If the image is sent through PC, make sure the size of the widget(s) does not exceed 400 MB in total, and that the profile size does not exceed 450 MB. ◆ Note: <ol style="list-style-type: none"> 1. The video or image may change in size depending on the resolution of the connected display and the number of widgets included to the profile. For a list of supported map and widget size between 1080p and 4K displays, see <i>Map & Widget Size</i>, page 44. 2. Please note that when using a media widget from HDMI in port, a certain degree of latency may occur due to video processing. For a list of supported EDID resolution, see <i>Supported HDMI In Resolutions</i>, page 46. 3. When access files via USB port is selected, any media files stored in the root directory of a USB drive will play sequentially. The USB drive supports NTFS, exFAT, and FAT32 file systems.

Item	Sub-Item	Description
		<p>4. The maximum supported video file resolution varies depending on how many widget and the source input is selected. For more details on the recommended resolution, see <i>Supported Widget Resolution from Different Input Source</i>, page 46.</p> <p>5. If the HDMI input source is hot-plugging, which means the input source was removed and added back into the unit without shutting the unit down, it takes approximately 30 seconds to show display.</p> <ul style="list-style-type: none"> ◆ URL: Enter an web URL in the Input URL field. ◆ RSS: Select Rss and click Edit. From the pop-up window, follow the on-screen instruction to copy and paste the RSS feed (URLs) to the pop-up window box.

■ **Booking Settings**

Item	Sub-Item	Description
Meeting Room Bookings		Enable or disable meeting room bookings.
Working Hours		Sets up the office working hours to the infoPlayer.

Setting Up a Map View for the infoPlayer Display

Why Using the Map View

The infoPlayer shows room usage status and meeting details on a dedicated part of the connected display. The default setup uses *list view*, where room information is shown by listing all rooms, along with their meeting details and upcoming meetings, as shown below.

List View

The screenshot shows the infoPlayer interface in 'List view' mode. At the top, there is a 'Lobby Preview' header with a dropdown menu set to 'List view'. Below this is a dark-themed header area containing the text 'Location name', three icons (fork and knife, two people, and a building), and the time '10:58' with the date 'Monday, Sep 25'. A 'News' section follows, featuring two articles: 'ATEN Control System Wins Good Design Award 2022' and 'ATEN Management Platform Wins'. The bottom portion of the screen is a table with three columns: 'Room Name', 'Meeting in Progress', and 'Next Meeting'. The table contains five rows of data, with some cells highlighted in green to indicate availability.

Room Name	Meeting in Progress	Next Meeting
Room Name Starts in 2 minutes	14:30 ~ 16:00 Meeting Subject Meeting Host	14:30 ~ 16:00 Meeting Subject Meeting Host
Room Name Starts in 2 minutes	Available 30 minutes	14:30 ~ 16:00 Meeting Subject Meeting Host
Room Name Starts in 2 minutes	14:30 ~ 16:00 Meeting Subject Meeting Host	Available 25 minutes
Room Name Starts in 2 minutes	14:30 ~ 16:00 Meeting Subject Meeting Host	Available 25 minutes
Room Name Starts in 2 minutes	14:30 ~ 16:00 Meeting Subject Meeting Host	14:30 ~ 16:00 Meeting Subject Meeting Host

As opposed to list view, the infoPlayer can also display this information in map view, where room usage status is displayed onto a floor plan, and also show facility locations. To use this feature, a map will need to be configured and uploaded in advance.

Map View

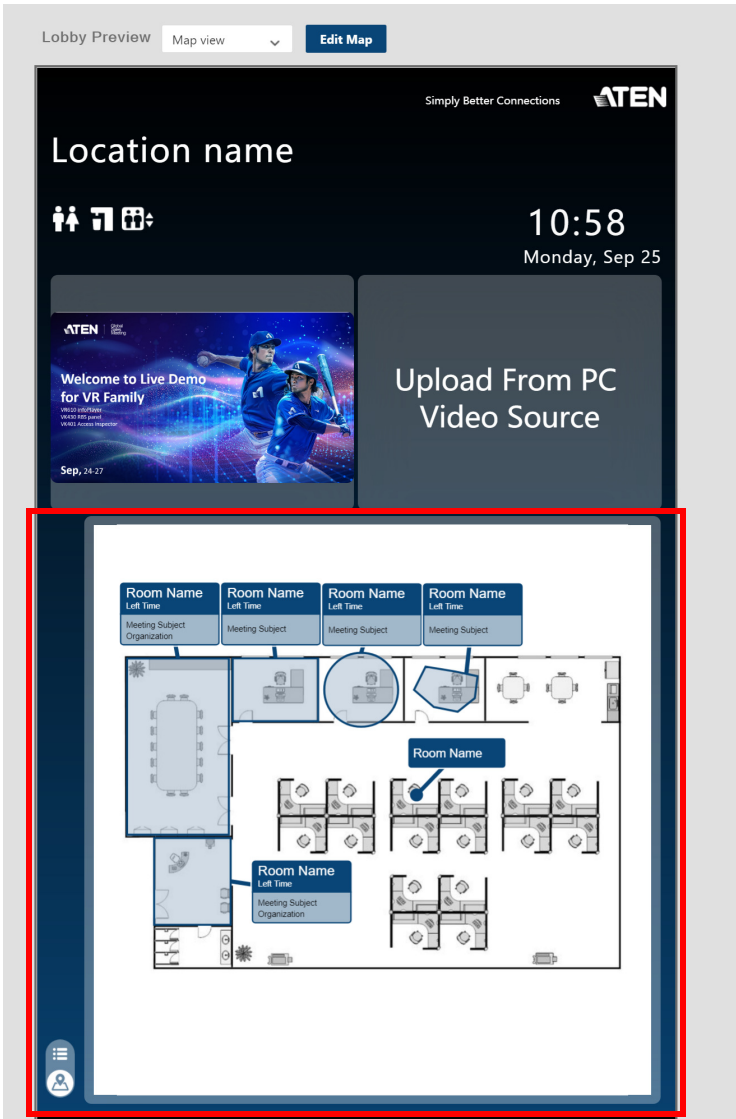

Switching between List View and Map View

With the map view configured in advance, you may also keep both list view and map view available and switch the view by tapping the indicated toggle button when needed.

The screenshot displays the ATEN Lobby interface. At the top right, it says "Simply Better Connections" and the ATEN logo. The main title is "ATEN Lobby". Below the title, there are columns for "Room name", "Meeting in Progress", and "Next Meeting".

Room name	Meeting in Progress	Next Meeting
War Room Until 11:30 AM today	Available 28 minutes	11:30 AM ~ 2:00 PM Chairman's Monthly Meeting Lynn Yang
Boardroom Release in 58 minutes	10:00 AM ~ 12:00 PM Lobby View UI Discussion Ashley Huang	4:00 PM ~ 5:00 PM RBS System Structure Discussion Tiffany Wang
Room301 Until 12:30 PM today	Available 88 minutes	12:30 PM ~ 1:30 PM Control System Spec Discussion Mike Taro
Room302 Release in 28 minutes	10:00 AM ~ 11:30 AM AVS Monthly Meeting Lynn Yang	Available 1hr 30 minutes
Room303 Release in 8 minutes	11:00 AM ~ 12:00 PM Global PM Meetings Ivy Pung	2:00 PM ~ 5:00 PM VE89 Unizon Integration Eva Hsiao

On the right side, there is a "News" section with two articles: "ATEN Control System Wins Good Design Award 2022" and "ATEN's New Open API Facilitates Integration with Third-Party Controllers". Below the news is a "BREAKING NEWS" banner featuring a man speaking into a microphone.

At the bottom left, there is a toggle button (a circle with a map icon) highlighted by a red box. Below it, a message states: "Today the company will conduct disinfection operations after get off work. Please do not work overtime." The time and date "11:02 AM Monday, Sep 25" are shown at the top right.

Configuring a Map

1. In RBS Configurator, go to **Edit Profile > Lobby Viewer Profile**.
2. To add a new lobby profile, click **Add New**, or click on an existing profile where you wish to configure the map.
3. In the pop-up window, click the **Edit Map** button.

Note: If you can't find the **Edit Map** button, make sure Lobby Preview (a setting on top of the preview panel) is set to **Map View**.

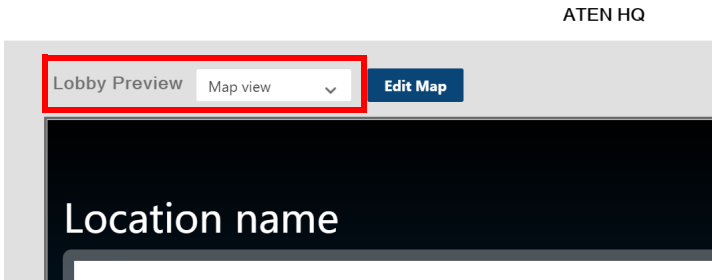

The map editor window appears.

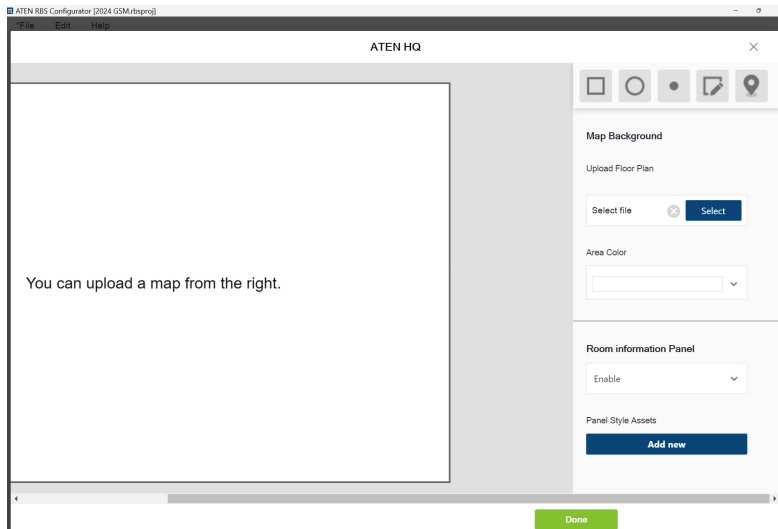





4. To add a floor plan, click **Select** to browse and upload.

5. To add a room information panel (showing room name, current/upcoming meeting details) and have meeting room changes color to indicate its status (available, reserved, occupied), outline each meeting room/space.

Note: To only show room information panel, skip this step and proceed to the next one.

- a) Depending on the shape of the target space, click one of the following tools.

Tool	Function
	Outlines a rectangular space and adds a room information panel.
	Outlines a circular space and adds a room information panel.
	Adds a room information panel.
	Outlines an irregular space and adds a room information panel.
	Adds facility signs. Click to select an icon from the pop-up menu to add facilities.

- b) Move the mouse to the map. A cross appears to indicate your mouse position.

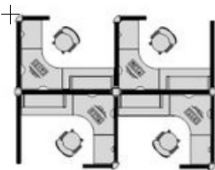

- c) Drag-and-drop the mouse over a room to outline it. A room location marker and a room information panel appears, overlapping each other.

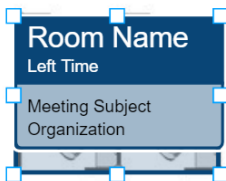

Note: The room information panel shows room name, remaining time, meeting subject, and organization name by default. To customize or create new styles, click **Add New** from the Panel Style Assets setting in the map editor window.

d) Click, drag-and-drop the room location marker and room information panel to move them to a suitable place.

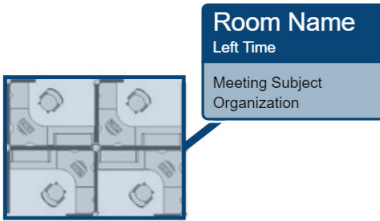

Or use the Properties filed to adjust the position of the room location marker to a suitable place.

Properties

Position

X	<input type="text" value="510"/>	Y	<input type="text" value="47"/>
W	<input type="text" value="102"/>	H	<input type="text" value="50"/>

Room Information Panel

X	<input type="text" value="739"/>	Y	<input type="text" value="10"/>
---	----------------------------------	---	---------------------------------

Or use the Properties filed to adjust the position of the room information panel to a suitable place.

Properties

Position

X	<input type="text" value="510"/>	Y	<input type="text" value="47"/>
W	<input type="text" value="102"/>	H	<input type="text" value="50"/>

Room Information Panel

X	<input type="text" value="739"/>	Y	<input type="text" value="10"/>
---	----------------------------------	---	---------------------------------

- e) To adjust the size of the room location marker, click on the box again. Drag on the sides to adjust it.

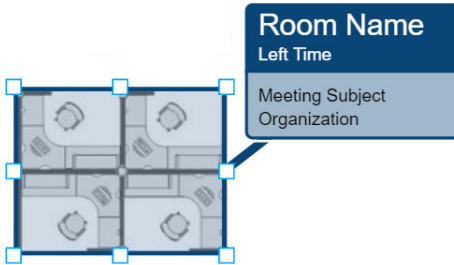

Or use the Properties filed to adjust the size of the room location marker.

Properties

Position

X <input type="text" value="510"/>	Y <input type="text" value="47"/>
W <input type="text" value="102"/>	H <input type="text" value="50"/>

Room Information Panel

X <input type="text" value="739"/>	Y <input type="text" value="10"/>
------------------------------------	-----------------------------------

Note: You can have the room information panel hidden by disabling the **Room Information Panel** setting.

6. To only show room information panel, click and click on the map to add a room information panel.

- To add facility signs, click  , select an icon from the pop-up menu to add facilities. Once the facilities are added into the map, you can click and drag the facility to a desired location..

Panel Assets



- Click **Done** to save the configuration.

Map & Widget Size

Please see below tables for the supported map and widget size for 1080p and 4K resolutions with different display orientation.

1080p Display

	1920 x 1080 (Landscape)		1080 x 1920 (Portrait)	
No Widget	Map			
	1440 x 760		976 x 1570	
1 Widget	Map	Widget	Map	Widget
	1440 x 760	609 x 666	976 x 966	1048 x 588
2 Widgets	Map	Widget	Map	Widget
	1440 x 760	609 x 333	1053 x 1027	515 x 588
Spotlight View	Spotlight Widget			
	1575 x 842		1080 x 1549	

4K Display

	3840 x 2160 (Landscape)		2160 x 3840 (Portrait)	
No Widget	Map			
	2880 x 1520		1940 x 3160	
1 Widget	Map	Widget	Map	Widget
	2440 x 1600	1200 x 1080	2000 x 2020	2000 x 940
2 Widgets	Map	Widget	Map	Widget
	2440 x 1600	1200 x 680	2020 x 2020	1030 x 1180
Spotlight View	Spotlight Widget			
	3120 x 1720		2160 x 3120	

Supported Widget Resolution from Different Input Source

	Upload from PC Access Files via USB Port Url	Access Files via HDMI In Port
1 Widget	Up to 4K @ 30 Hz 1080p @ 60 Hz is recommended	Up to 1080p @ 60 Hz
2 Widgets	Up to 1080p @ 60 Hz	Up to 1080p @ 60 Hz
Spotlight Widget	Up to 4K @ 30 Hz 1080p @ 60 Hz is recommended	Up to 1080p @ 60 Hz

Supported HDMI In Resolutions

EDID Resolutions
1920 x 1080p @ 60 Hz (Native)
1280 x 720p @ 60 Hz
720 x 480p @ 60 Hz
640 x 480p @ 60 Hz
720 x 576p @ 50 Hz
1920 x 1080p @ 30 Hz

Note: The HDCP protected content is not supported.

RBS Panel Profiles

The **Edit Profile** tab, in ATEN RBS Configurator, allows you to customize layout design profiles and define booking settings to be applied to any ATEN RBS Panels managed.

Adding New Panel Profiles

In RBS Configurator, click **Edit Profile** and select **Room Panel Profile**. This screen appears.

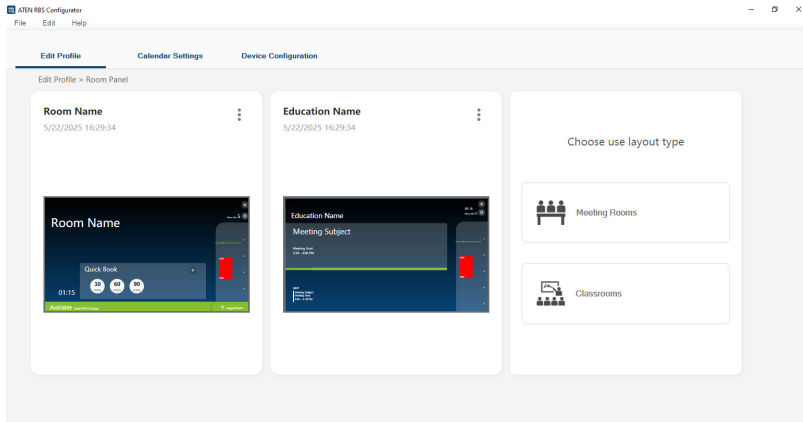

Adding Meeting Rooms

To add a new meeting room, follow the steps below.

1. Click **Meeting Rooms**.

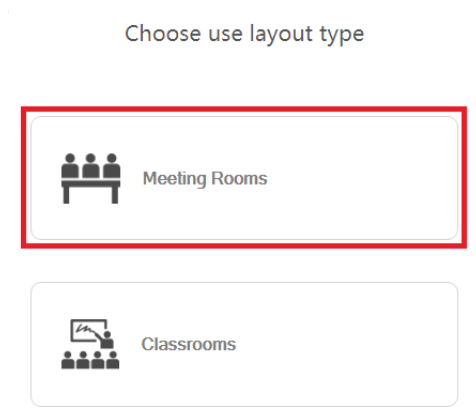

2. This dialog box appears.

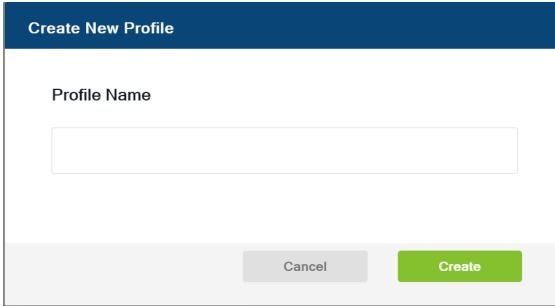

3. In the pop-up dialog box, name the profile and click **Create**. A panel profile is created.

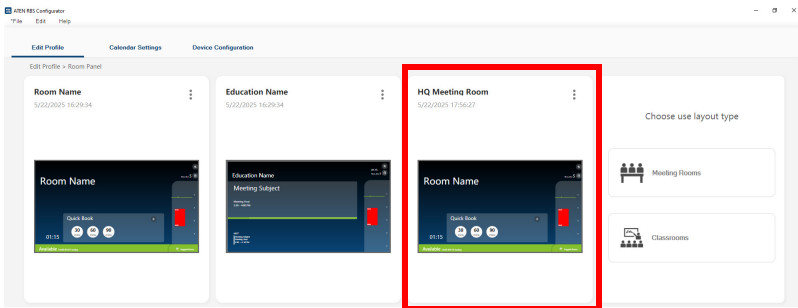

Adding Classrooms

To add a new classroom, follow the steps below.

1. Click **Classrooms**.

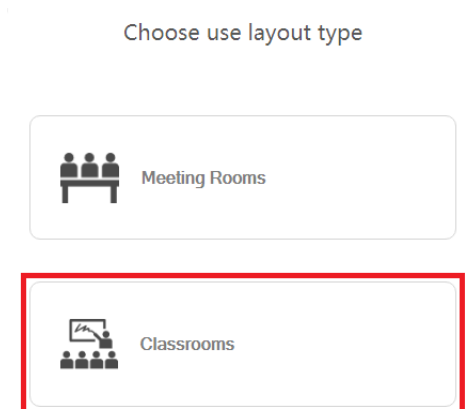

2. This dialog box appears.

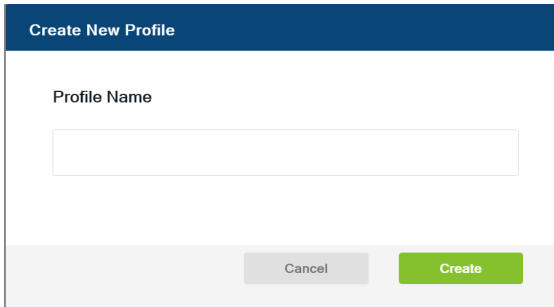

The dialog box has a dark blue header with the text "Create New Profile". Below the header, the text "Profile Name" is displayed above a white rectangular input field. At the bottom of the dialog, there are two buttons: a grey "Cancel" button and a green "Create" button.

3. In the pop-up dialog box, name the profile and click **Create**. A panel profile is created.

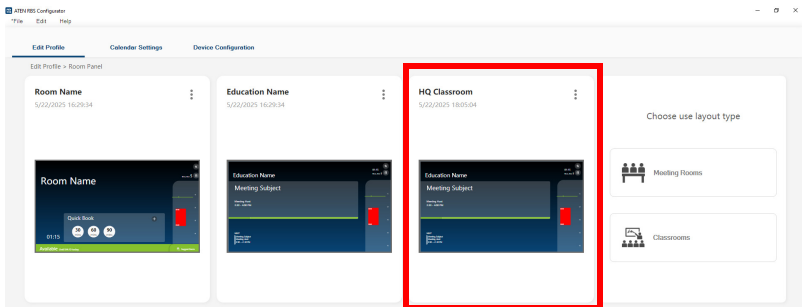

Editing Profile Names, Duplicating and Deleting Profiles

In RBS Configurator, click the  button of a panel profile to access the following options:

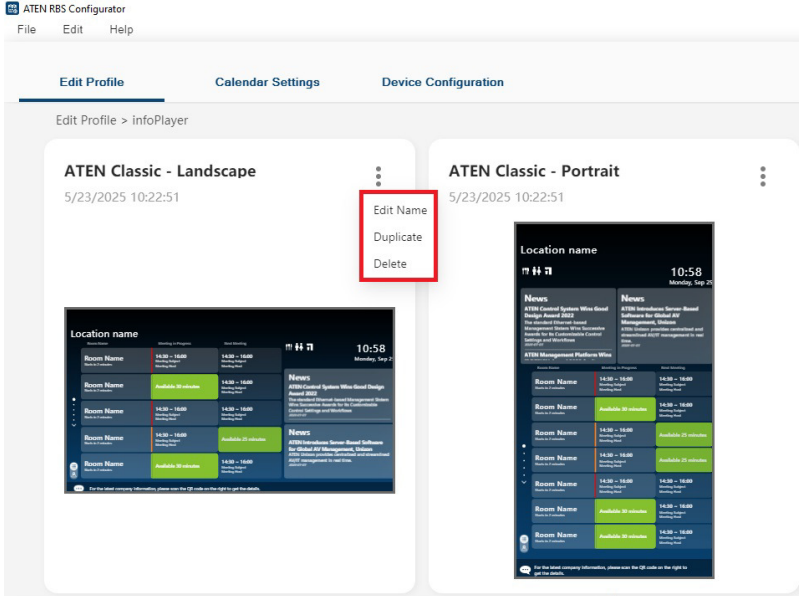

Item	Description
Edit Name	Edits the name of the profile.
Duplicate	Creates a duplicate of the profile.
Delete	Deletes the profile.

Configuring Panel Profiles

In RBS Configurator, go to **Edit Profile > Room Panel Profile**, and then click on a desired profile to start. The following page appears.

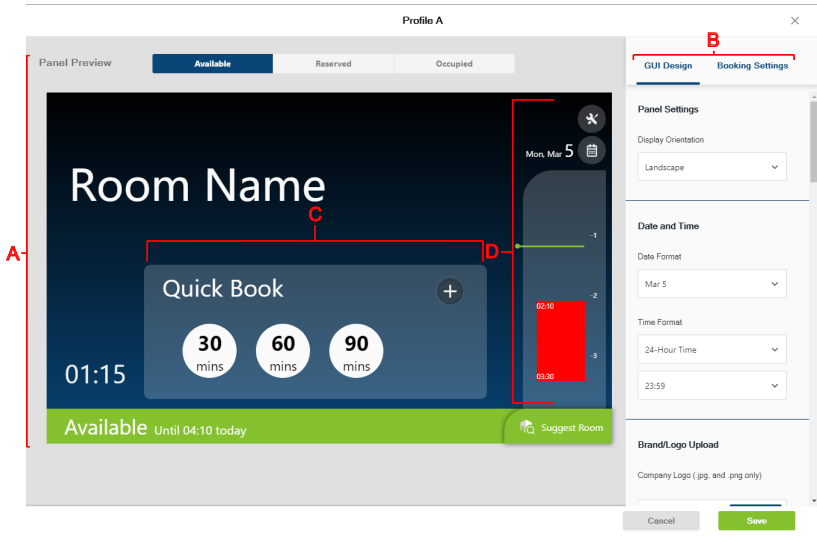

No.	Item	Description
A	Panel Preview	Displays an example of how the panel layout would look like once the profile is applied.
B	Interface and Booking Settings	Contains the following: <ul style="list-style-type: none"> ◆ GUI Design: Defines the profile's layout design related settings. ◆ Booking Settings: Sets the profile's booking-related settings
C	Check-in Panel	Used for checking-in to a meeting room and quick booking. Note: Classroom does not have the Check-in Panel area.
D	Daily Schedule Area	Displays the room's reservation schedule for the day.

GUI Design

Overview

Item	Sub-Item	Description
Panel Settings	Display Orientation	<p>Based on how your RBS panel is installed, select one of the following options for the system to provide an output that fits.</p> <ul style="list-style-type: none"> ◆ Portrait: A portrait orientation shows content with great height than width in the displayed area. ◆ Landscape: A landscape orientation shows content with great width than height in the displayed area.
Date and Time	Date Format	Sets the format in which date is displayed on the RBS Panel.
	Time Format	Sets the format in which time is displayed on the RBS Panel.
Brand/Logo Upload	Upload Company Logo	Uploads a brand logo image (.jpg, .jpeg, .png, or .bmp), up to 140*970 pixels, to be displayed on the upper-left of the RBS Panel.
Background	Main Page	Defines the background of the RBS Panel's main page, either by selecting a color or uploading an image (.jpg, .jpeg, .png, or .bmp), up to 1280*732 pixels.
	Blur Background	Enable to show the background shown in gradient color. For more details, see <i>Blurring the Background</i> , page 54.
Room Name Text Color		Sets the color depth between dark and light in which room name is displayed on the RBS Panel.
Time Display Text Color (meeting rooms layout type only)		Sets the color depth between dark and light in which time is displayed on the RBS Panel.
Room Panel Color		Sets the color depth between dark and light of the RBS Panel's check-in panel.

Item	Sub-Item	Description
Daily Schedule Area	Icon Color	Sets the color depth between dark and light of icons on the RBS Panel's daily schedule area.
	Date Display Text Color	Sets the color depth between dark and light in which day and date are displayed on the RBS Panel.
	Style	Sets the display style (style 1 / style 2 / style 3) and color depth between dark and light of the RBS Panel's daily schedule area.
Status Color	Available	Sets the color of the LED bars of the RBS Panel, and its status color, when it is available for use.
	Reserved (meeting rooms layout type only)	Sets the color of the LED bars of the RBS Panel, and its status color, when it is reserved for a meeting.
	Occupied	Sets the color of the LED bars of the RBS Panel, and its status color, when it is occupied.
Meeting Information (meeting rooms layout type only)		<ul style="list-style-type: none"> ◆ Displays a summary of the currently ongoing meeting with an information icon on the top-right corner of the check-in panel. ◆ Allows you to cancel a meeting (using a Delete Meeting button) if the meeting was booked through the panel.
Working Hour Countdown (meeting rooms layout type only)		<p>Displays the remaining time (in minutes) for the next room status on the meeting status bar. Depending on the current room status, different information is shown. For example:</p> <ul style="list-style-type: none"> ◆ Available until 15:00 today ◆ Reserved Starts in 2 minutes ◆ Occupied Ends in 13 minutes
Screen Mode	Mode	<p>Sets the screen saver mode between text and video mode.</p> <ul style="list-style-type: none"> ◆ Text mode is available for VK430 and VR440. ◆ Video mode is only available for VR440.
	Show Spotlight Mode After	Select an idle time to display the screen saver when the RBS panel has idled for the selected duration. By default, the screen saver is enabled and set to display when RBS panel has idled for 5 minutes.
	Text Color	Sets the text color of the screen saver.

Blurring the Background

Use the **blur background** function to have the Quick Book controls stand out by applying color gradient to the background, as show below.

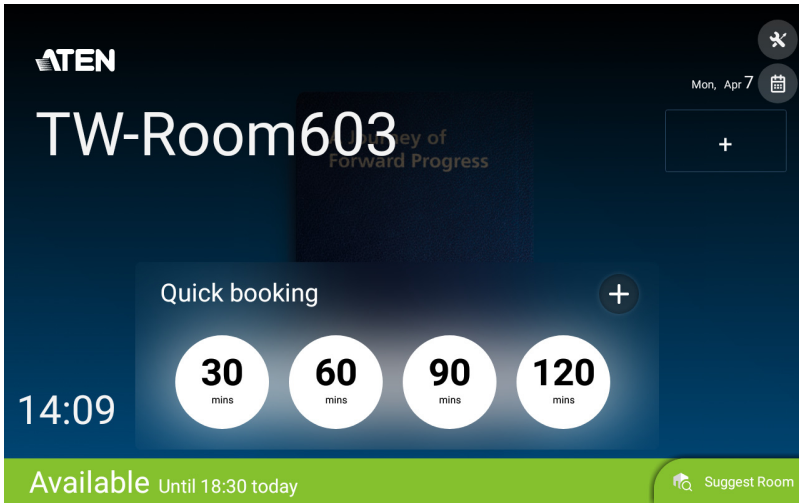

Disable the blur background function to use the chosen background without the gradient effect, as shown below.

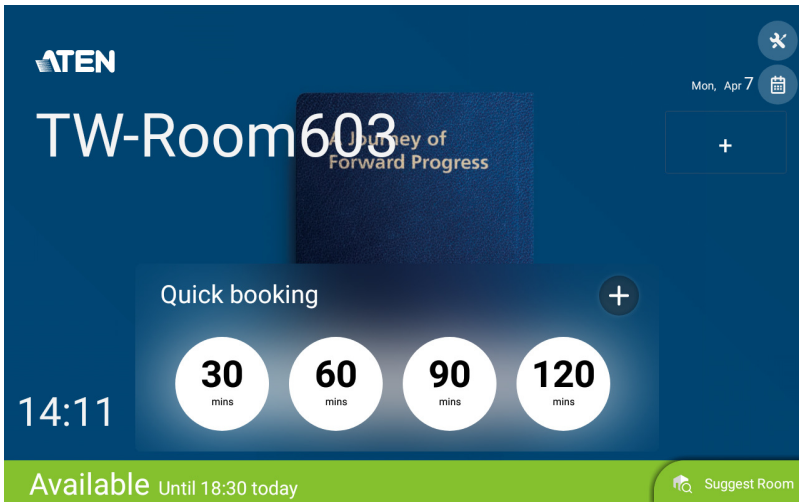

To access the blur background setting:

1. In RBS Configurator, open the profile file.
2. Click on the target template. The configuration page appears.
3. Under GUI Design, scroll down to find **Blur Background**.

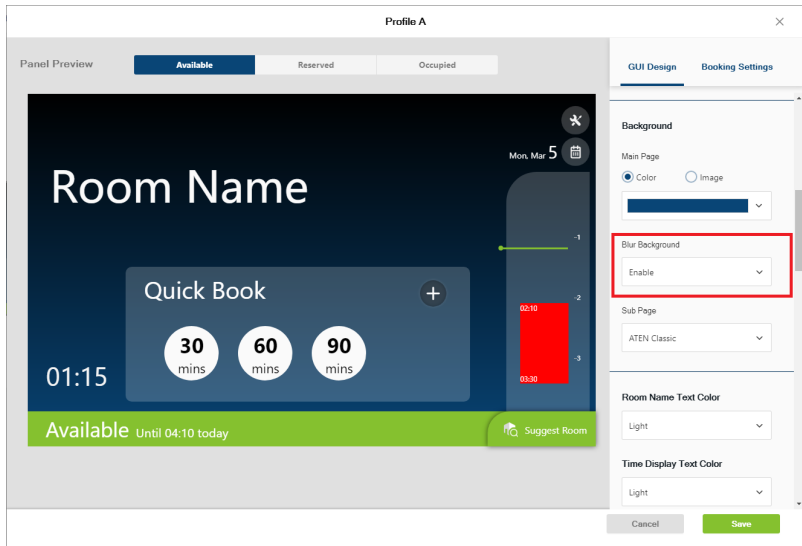

4. Configure the setting and click **Save** to apply the change.

Booking Settings

Item	Sub-Item	Description
Sign-On Period	Allow sign-on before event starts by	Sets the time window for recording student attendance before and after the start of event. See <i>Using Sign-on for Attendance Record with Unizon</i> , page 144. Note: To enable this feature, configure the options under Identity Checkup in Device Configuration .
	Allow sign-on after event starts by	
Quick Booking, Suggest Room, Calendar Bookings (meeting rooms layout type only)		Enable to allow quick booking options to be available on the RBS Panel's check-in panel.
Room Utilization Optimization (meeting rooms layout type only)	Room will be released if not checked in within the time set.	Enable to: <ul style="list-style-type: none"> optimize room usage by releasing the room when not checked in within the defined time frame. allow meeting extension, early check-in, and delayed check-in. When disabled, a room will not be released if not checked in, and will not support early/delayed check-in and reservation extension.
	Extend Meeting	Enable to allow meeting extension.
	Allow check-in before the scheduled time by	Sets the amount of time allowed for early check-in.
	Hold for	Sets the amount of time allowed for late check-in before being released.
System Information Display		<ul style="list-style-type: none"> Check to select the information to be displayed on the RBS Panel. Uncheck everything to leave the RBS Panel with no information.
Room Panel Information		Use this setting to define which types of information that you want to display as the title and subtitle on the home page.
Working Hours	Calendar Server	Adopt the working hours as specified in the connected calendar server.
	Manual	Set up the working hours for the room booking system.
	Off-duty Brightness	Sets the brightness of the RBS Panel during off-duty hours.

Click **Save** for changes to take effect.

Chapter 4

Calendar Server

This chapter guides you through the implementation of your ATEN Room Booking System to calendar servers supported, including Microsoft 365 Calendar, Microsoft Exchange Server, Google Workspace, and DingTalk for convenient scheduling management of all conference rooms in the system.

Microsoft 365

Setup Overview

To set up a Microsoft 365 Calendar for managing your ATEN Room Booking System, follow the steps below.

1. Using the Microsoft 365's administrator account, do the following:
 - a) Add a user account for every person who is allowed to book room resources through the Microsoft 365 calendar server.
For a detailed procedure, see *Adding User Accounts*, page 58.
 - b) Decide an authentication method to use.
For more information, see *Deciding the Authentication Method*, page 59.
 - c) Add a resource account, while setting a password, for every conference room to be managed by the Room Booking System.
For a detailed procedure, see *Deciding the Authentication Method*, page 59.
 - d) To use account credentials to authenticate, add a user account as delegate.
For a detailed procedure, see *Adding a Room (Resource) Account*, page 60.
 - e) To use account credentials to authenticate, turn off multifactor authentication (MFA).
For a detailed procedure, see *Adding a Room (Resource) Account*, page 60.

- f) Through Microsoft Entra, register for an APP ID and add the required API permission for the Room Booking System. For detailed procedures, see:
 - ◆ *Configuring Microsoft Entra (for using Account Credentials)*, page 65.
 - ◆ *Configuring Microsoft Entra (for using Client Secret Keys)*, page 70.
2. On your ATEN RBS Configurator:
 - a) Configure the account settings. For details, see *Account Settings*, page 77.
 - b) Configure room grouping. This is a setting that helps refine the list of available rooms that appear when using the Suggest Room function on RBS panels. For details, see *Configuring Room Grouping*, page 78.

Microsoft 365 Admin Center

To start, log into <https://admin.microsoft.com/> using the Microsoft 365's administrator account credentials.

Adding User Accounts

Add a user account for every person who is allowed to book room resources through the Microsoft 365 calendar server, by doing the following:

1. In the Microsoft 365 admin center, go to **Navigation Menu > Users > Active Users** and click **Add a user**.

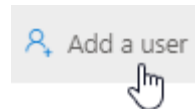
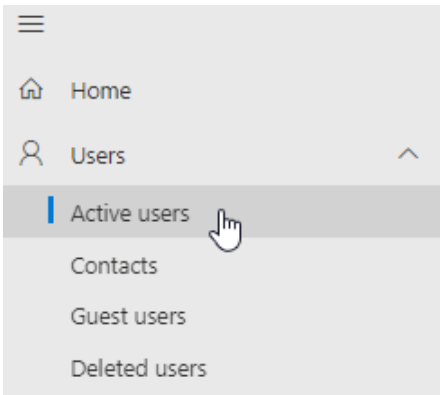

2. Fill in the basic information for the user and click **Next**.

Add a user

Basics

Product licenses

Optional settings

Finish

Set up the basics

To get started, fill out some basic information about who you're adding as a user.

First name

Last name

Display name *

Username *

Domains

Automatically create a password

Next Cancel

3. Based on the purchased license types, different options may be available. Select a one that supports Exchange Online.
4. Follow the on-screen instructions to create the user account.

Deciding the Authentication Method

Decide the authentication method for the calendar server, either through account credentials or a client secret key. For a comparison of the pros and cons of the two methods, take a look of the following table.

	Using Account Credentials	Using Client Secret Key
Pros	No need to regularly upload the credentials as long as the account credentials stay the unchanged	<ul style="list-style-type: none"> ◆ No need to turn off multifactor authentication ◆ Flexible for different network environment
Cons	Need to turn off multifactor authentication. This may not be approved for some companies due to security concerns	Regular upload of the client secret key to RBS Configurator every (3 to 24 months, as configured on Microsoft 365) is needed

Adding a Room (Resource) Account

Add a room account, and set a required password for every conference room to be managed by ATEN RBS, by doing the following:

1. In the Microsoft 365 admin center, go to **Navigation Menu > Resources > Rooms & equipment** and click **Add resource**

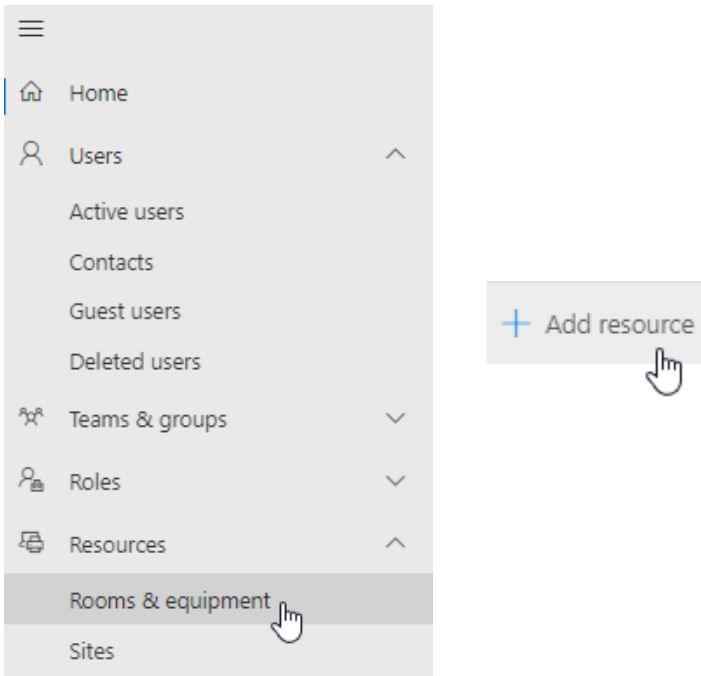

2. Select **Room** from the *Resource type* drop-down list and then follow the on-screen instructions to create the room account.

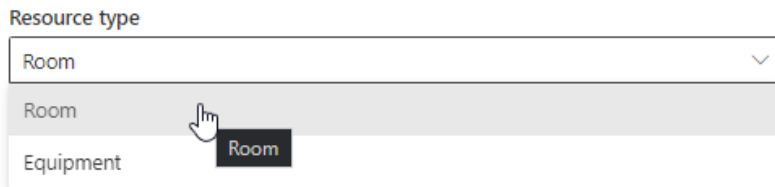

- If you use account credentials for authentication, right-click on the created room and then click **Edit** to add delegates. To ensure booking rights for all delegate in all rooms, make sure to add the delegates to each room.

Rooms & equipment

+ Add resource Refresh Edit resource mailbox details

Name	Email
<input type="checkbox"/> JP-Room1	JP-Room1@...
<input type="checkbox"/> KR-Room1	KR-Room1@...
<input type="checkbox"/> KR-Room2	KR-Room2@...
<input type="checkbox"/> TW-Room1	TW-Room1@...
<input checked="" type="checkbox"/> UK-Room1	UK-Room1@...

UK-Room1
Room

Contact information

Name	Email
UK-Room1	UK-Room1@rbspm.onmicrosoft.com
Capacity	Location
Phone number	

[Edit](#)

Delegates (0)
[Edit](#)

[Exchange settings](#)
[Edit Exchange settings](#)

- Go to **Navigation Menu > Users > Active Users**, click **Reset a password** next to the room account created from step 2 and follow the on-screen instructions to define its password.

Note: Make sure a password has been set for every room account created.

Adding a User Account as Delegate

To use account credentials for authentication, follow the procedure below to add a user account as delegate.

1. In the Microsoft 365 admin center, go to **Navigation Menu > Users > Active Users** and click **Add a user**.
2. Fill in the basic information for the user and click **Next**.

Add a user

- Basics
- Product licenses
- Optional settings
- Finish

Set up the basics

To get started, fill out some basic information about who you're adding as a user.

First name

Last name

Display name *

Username *

Domains

Automatically create a password

[Next](#) [Cancel](#)

3. Based on the purchased license types, different options may be available. Select a one that supports Exchange Online.
4. Follow the on-screen instructions to create the user account.
5. Assign the delegate to **All Company Group**.

Home > Active users

Active users

[Add a user](#) [Multi-factor authentication](#) [Refresh](#) ...

<input type="checkbox"/>	Display name ↑	Username
<input type="checkbox"/>	book room	bookroom@...
<input type="checkbox"/>	JP-Room1	JP-Room1@...
<input type="checkbox"/>	KR-Room1	KR-Room1@...
<input type="checkbox"/>	KR-Room2	KR-Room2@...
<input type="checkbox"/>	MR	mr@rbspm...
<input type="checkbox"/>	PL-Room	PL-Room@r...
<input type="checkbox"/>	Ted Wang	admin@rbsp...

TI

Tiffany

[Reset password](#) [Block sign-in](#) [Delete user](#)

[Account](#) [Devices](#) [Licenses and apps](#) [Mail](#) [OneDrive](#)

Username and email

Tiffany@rbspm.onmicrosoft.com

[Manage username and email](#)

Last sign-in

February 14, 2022, 4:20 PM

[View last 30 days](#)

Alternate email address

None provided

[Add address](#)

Aliases

[Manage username and email](#)

Sign-out

Sign this user out of all Office 365 sessions.

[Sign out of all sessions](#)

Groups

All Company

[Manage groups](#)

Turning Off Multifactor Authentication (MFA)

To use account credentials for authentication, follow the procedure below to turn off multifactor authentication (MFA).

1. In the Microsoft 365 admin center, go to **Navigation Menu > Users > Active users > Multi-factor authentication**.

The screenshot shows the Microsoft 365 admin center interface. On the left is a navigation menu with 'Active users' highlighted in a red box. The main content area shows 'Active users' with a search bar and a list of users. A dropdown menu is open for the 'demo_uk' user, with 'Multi-factor authentication' highlighted in a red box. Other options in the dropdown include 'Delete a user', 'Refresh', 'Reset password', 'Export users', 'Directory synchronization', and 'Teams setup status'.

2. Click **Legacy per-user MFA**.

Configure multifactor authentication (MFA)

Secure your organization against breaches due to lost or stolen credentials. MFA immediately increases account security by prompting for multiple forms of verification to prove a user's identity when they sign in to an app or other company resource. This prompt could be to enter a code on the user's mobile device or to provide a fingerprint scan. MFA is enabled through Conditional Access, security defaults, or per-user MFA. This guide will provide the recommended MFA option for your org, based on your licenses and existing configuration.

Conditional Access policies detected, select **Manage** to edit the policies. Not what you're looking for? To configure MFA on a individual per-users level, select **Legacy per-user MFA**.

[Manage](#)

✔ Completed

3. Disable MFA for both the delegate and resource accounts.

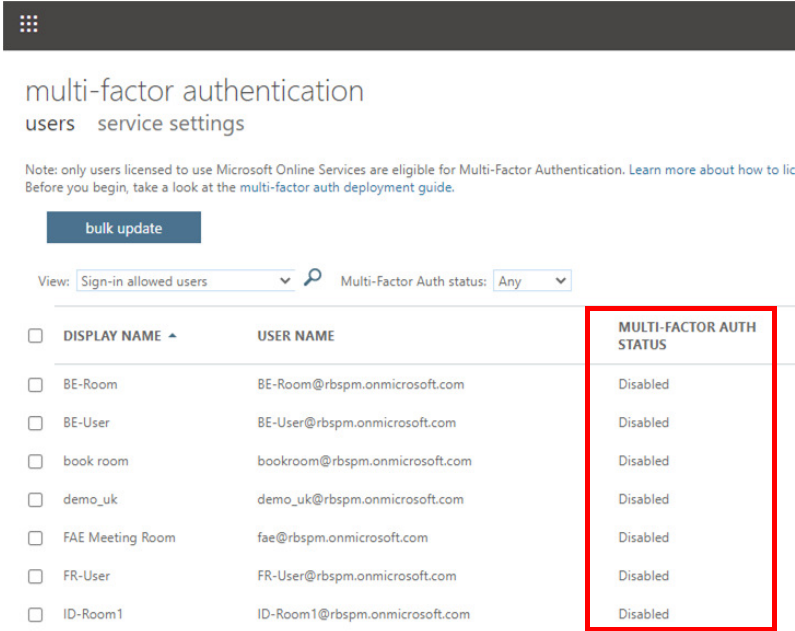

multi-factor authentication
users service settings

Note: only users licensed to use Microsoft Online Services are eligible for Multi-Factor Authentication. [Learn more about how to lic](#)
Before you begin, take a look at the [multi-factor auth deployment guide](#).

bulk update

View: Sign-in allowed users Multi-Factor Auth status: Any

<input type="checkbox"/>	DISPLAY NAME ^	USER NAME	MULTI-FACTOR AUTH STATUS
<input type="checkbox"/>	BE-Room	BE-Room@rbspm.onmicrosoft.com	Disabled
<input type="checkbox"/>	BE-User	BE-User@rbspm.onmicrosoft.com	Disabled
<input type="checkbox"/>	book room	bookroom@rbspm.onmicrosoft.com	Disabled
<input type="checkbox"/>	demo_uk	demo_uk@rbspm.onmicrosoft.com	Disabled
<input type="checkbox"/>	FAE Meeting Room	fae@rbspm.onmicrosoft.com	Disabled
<input type="checkbox"/>	FR-User	FR-User@rbspm.onmicrosoft.com	Disabled
<input type="checkbox"/>	ID-Room1	ID-Room1@rbspm.onmicrosoft.com	Disabled

Configuring Microsoft Entra (for using Account Credentials)

Registering Application

Register to obtain an Application ID for the ATEN Room Booking System, by doing the following:

1. In the Microsoft 365 admin center, go to **Navigation Menu > All admin centers** and select **Microsoft Entra**.

The screenshot shows the Microsoft 365 admin center interface. The left-hand navigation menu is expanded to show 'All admin centers', which is highlighted with a red box. The main content area displays a list of admin centers. The 'Microsoft Entra' item at the bottom of the list is also highlighted with a red box.

Name	Description
Azure ATP	Identify, detect, and investigate advanced threats organization.
Compliance	Use the Microsoft Purview compliance portal to help protect sensitive info, manage data lifecycle
Dynamics 365 Apps	Use the Dynamics 365 admin center to manage y operations.
Endpoint Manager	A single management experience for the End Use are secured, managed, and current.
Exchange	Manage advanced email settings, such as quaran
Microsoft Entra	Use the Microsoft Entra admin center to manage for Azure Active Directory.

2. Go to **Microsoft Entra admin center > Applications > App registrations** and click **New Registration**.

The screenshot shows the Microsoft Entra admin center interface. The breadcrumb 'Microsoft Entra admin center' is highlighted with a red box. The left-hand navigation menu is expanded to show 'Applications', which is also highlighted with a red box. The main content area displays the 'App registrations' page, where the '+ New registration' button is highlighted with a red box.

Starting June 30th, 2020 we will no longer add any new features to Azure Active Direct support and security updates but we will no longer provide feature updates. Application Graph. [Learn more](#)

All applications **Owned applications** Deleted applications

Start typing a display name or application (client) ID to filter these r...

23 applications found

Display name ↑

3. Enter a desired name, select **Accounts in this organizational directory only** under *Supported account types*, and click **Register**.

Register an application ...

* Name
The user-facing display name for this application (this can be changed later).

RBS_APP ✓

Supported account types
Who can use this application or access this API?

- Accounts in this organizational directory only (rbspm only - Single tenant)
- Accounts in any organizational directory (Any Azure AD directory - Multitenant)
- Accounts in any organizational directory (Any Azure AD directory - Multitenant) and personal Microsoft accounts (e.g. Skype, Xbox)
- Personal Microsoft accounts only

[Help me choose...](#)

By proceeding, you agree to the [Microsoft Platform Policies](#) ☒

Register

4. Once registered successfully, the **Application ID** is displayed, which shall later be entered on your ATEN RBS Configurator.

^ Essentials

Display name
RBS_APP

Application (client) ID
01d6510e0-4d76-4030-9e7b-015d25f07500

Object ID
d0d70b25-6fbc-4bf4-9e2e-dd494d50e557

Directory (tenant) ID
71e111b20-2263-442e-866d-c3297c87721f

Supported account types
My organization only

- Go to **Authentication**, enable **Allow public client flows** by selecting **Yes**, and then click **Save** for the changes to take effect.

The screenshot shows the Microsoft Entra admin center interface. The left-hand navigation pane has 'App registrations' highlighted. The main content area is titled 'RBS_APP (NEW) | Authentication'. A warning message at the top states: 'Due to temporary differences in supported functionality, we don't recommend enabling personal Microsoft accounts for an existing registration. If you need to enable personal accounts, you can do so using the manifest editor. Learn more about these restrictions.' Below this, the 'Advanced settings' section has 'Allow public client flows' set to 'Yes'. A list of permissions is shown: 'App collects plaintext password (Resource Owner Password Credential Flow)', 'No keyboard (Device Code Flow)', and 'SSO for domain-joined Windows (Windows Integrated Auth Flow)'. The 'App instance property lock' is also visible. At the bottom, the 'Save' button is highlighted with a red box.

Adding API Permissions

After registering the application, also make sure the required API permissions have been applied to it, by doing the following:

- Click **API permissions** > **Add a permission**, and select **Microsoft Graph** > **Delegated permissions**

Dashboard > rbspm > RBS_APP

RBS_APP | API permissions

The screenshot shows the 'API permissions' page for RBS_APP. The left-hand navigation pane has 'API permissions' highlighted. The main content area has a search bar and a 'Refresh' button. Below the navigation pane, there is a list of permissions: 'Overview', 'Quickstart', 'Integration assistant', 'Manage', 'Branding & properties', 'Authentication', 'Certificates & secrets', 'Token configuration', and 'API permissions'. The 'API permissions' link is highlighted with a red box.

Search (Ctrl+/) Refresh Got feedback?

The "Admin consent required" column shows the default user, or app. This column may not reflect the value in your o

Configured permissions

Applications are authorized to call APIs when they are granted permissions should include all the permissions the application

+ Add a permission Grant admin consent for rbspm

API / Permissions name	Type	Description
------------------------	------	-------------

Microsoft Graph (1)

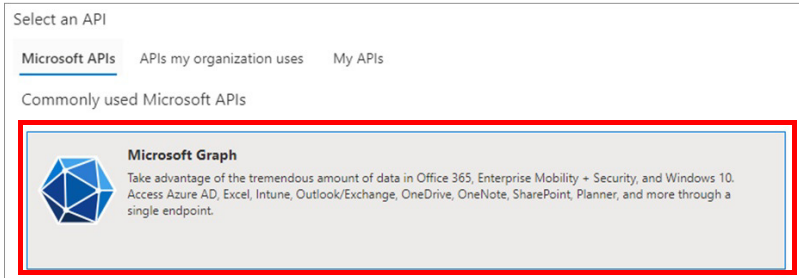

Request API permissions ×

[← All APIs](#)

 Microsoft Graph
<https://graph.microsoft.com/> [Docs](#) [↗](#)

What type of permissions does your application require?

<p>Delegated permissions Your application needs to access the API as the signed-in user.</p>	<p>Application permissions Your application runs as a background service or daemon without a signed-in user.</p>
---	---

2. Select the following 7 permissions.

- ◆ 4 Calendar permissions:
 - ◆ Calendars.Read
 - ◆ Calendars.Read.Shared
 - ◆ Calendars.ReadWrite
 - ◆ Calendars.ReadWrite. Shared
- ◆ 1 Place permission:
 - ◆ Place.Read.All
- ◆ 2 User permissions:
 - ◆ User.Read
 - ◆ User.Read.All

3. Select permissions and click Add permissions.

Request API permissions ×

Delegated permissions
Your application needs to access the API as the signed-in user.

Application permissions
Your application runs as a background service or daemon without a signed-in user.

Select permissions collapse all

Permission	Admin consent required
<div style="margin-left: 10px;"> ∨ Calendars (3) </div>	
<input checked="" type="checkbox"/> Calendars.Read ⓘ Read calendars in all mailboxes	Yes
<input checked="" type="checkbox"/> Calendars.ReadBasic.All ⓘ Read basic details of calendars in all mailboxes	Yes
<input checked="" type="checkbox"/> Calendars.ReadWrite ⓘ Read and write calendars in all mailboxes	Yes

Add permissions

Discard

4. Click **Grant admin consent for your account**, as illustrated below, and then click **Yes** to finish.

+ Add a permission ✔ Grant admin consent for rbspm

API / Permissions na...	Type	Description	Admin consent req...	Status
<div style="margin-left: 10px;"> ∨ Microsoft Graph (7) </div>				
Calendars.Read	Delegated	Read user calendars	No	<div style="border: 2px solid red; padding: 2px;"> ✔ Granted for rbspm </div>
Calendars.Read.Sha	Delegated	Read user and shared calendars	No	<div style="border: 2px solid red; padding: 2px;"> ✔ Granted for rbspm </div>

Grant admin consent confirmation.

Do you want to grant consent for the requested permissions for all accounts in aten3562? This will update any existing admin consent records this below.

Yes

No

Configuring Microsoft Entra (for using Client Secret Keys)

Registering the Application

Register to obtain an Application ID for the ATEN Room Booking System, by doing the following:

1. In the Microsoft 365 admin center, go to **Navigation Menu > All admin centers** and select **Microsoft Entra**.

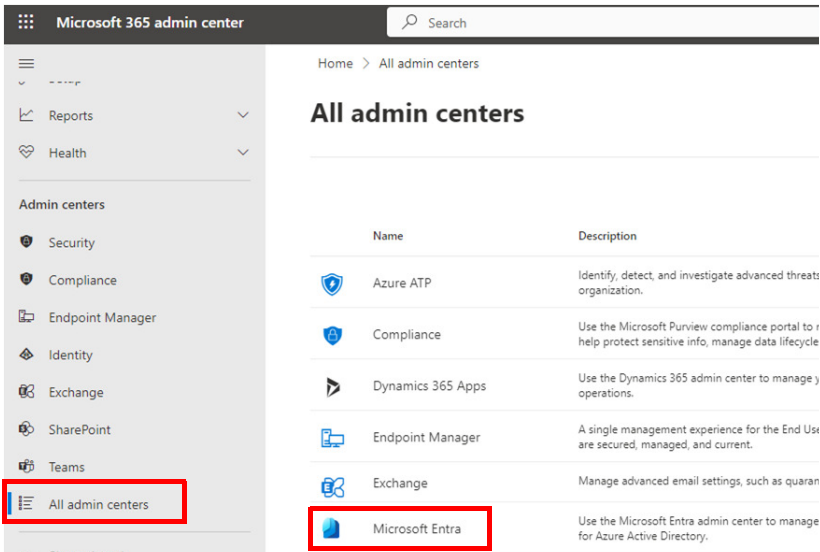

2. Go to **Microsoft Entra admin center > Applications > App registrations** and click **New Registration**.

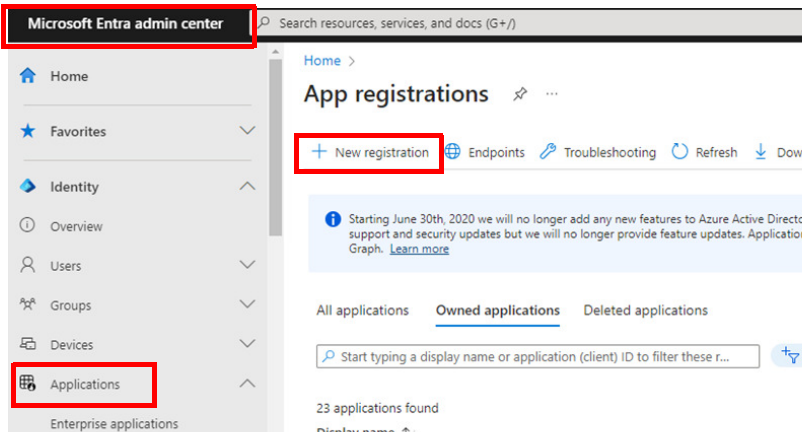

3. Enter a desired name, select **Accounts in this organizational directory only** under *Supported account types*, and click **Register**.

Register an application ⋮

*** Name**
The user-facing display name for this application (this can be changed later).

RBS_APP ✓

Supported account types
Who can use this application or access this API?

Accounts in this organizational directory only (rbspm only - Single tenant)
 Accounts in any organizational directory (Any Azure AD directory - Multitenant)
 Accounts in any organizational directory (Any Azure AD directory - Multitenant) and personal Microsoft accounts (e.g. Skype, Xbox)
 Personal Microsoft accounts only

[Help me choose...](#)

By proceeding, you agree to the [Microsoft Platform Policies](#) ↗

Register

4. Once registered successfully, the **Application (Client) ID** and Directory (tenant) ID are displayed. Save these IDs, which shall later be entered on your ATEN RBS Configurator.

^ Essentials

Display name
RBS_APP

Application (client) ID
01d9610e0-e076-40a0-9e7b-d15d25f07500

Object ID
d0d70b35-6fbc-4bf4-9e2e-dd494d50e557

Directory (tenant) ID
71e-111e-2a-c2a3-a42e-89ed-c2c2afca772111

Supported account types
My organization only

5. Go to **Authentication**, enable *Allow public client flows* by selecting **Yes**. Then click **Save** for the changes to take effect.

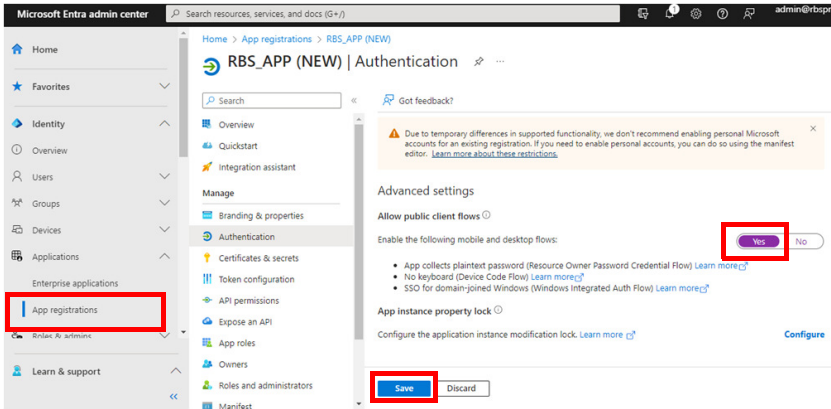

6. Go to **Certificates & secrets** > **New client secret**.

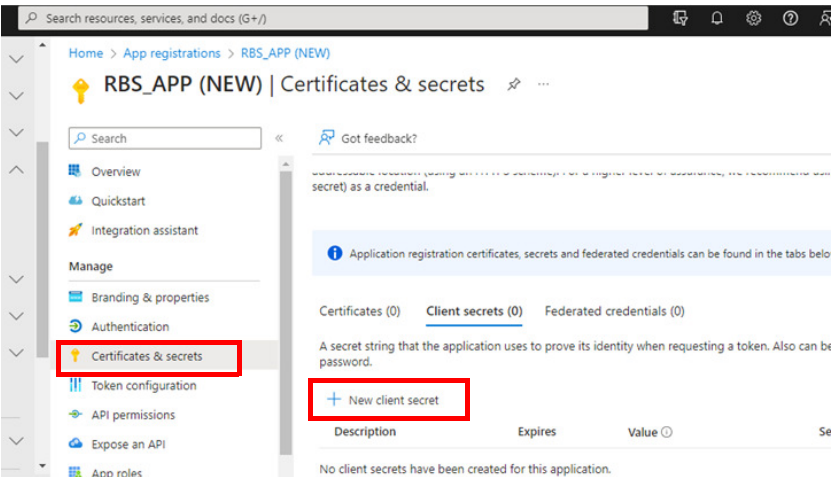

- In the pop-up dialog box, fill in a description and days of expiration for the new client secret. Click **Add**.

Note: If the client secret expires, create a new one and upload the renewed profile to RBS Configurator.

- A client secret is created. Copy and save the key for use later in RBS Configurator.

Important: Make sure to copy the key now. This key will not be visible or accessible once leaving the page.

Home > App registrations > RBS_APP (NEW)

RBS_APP (NEW) | Certificates & secrets

Overview
Quickstart
Integration assistant

Manage

- Branding & properties
- Authentication
- Certificates & secrets
- Token configuration
- API permissions
- Expose an API
- App roles

secret) as a credential.

Application registration certificates, secrets and federated credentials can be found in the tabs below.

Certificates (0) **Client secrets (1)** Federated credentials (0)

A secret string that the application uses to prove its identity when requesting a token. Also can be password.

+ New client secret

Description	Expires	Value
RBS_secret code	7/27/2024	86q8Q~PIRtI5okpXrSJa982...

Adding API Permissions

After registering the application, also make sure the required API permissions have been applied to it, by doing the following:

1. Click **API permissions** > **Add a permission**, and select **Microsoft Graph** > **Application permissions**.

[Dashboard](#) > [rbspm](#) > [RBS_APP](#)

RBS_APP | API permissions

Refresh
Got feedback?

Overview

Quickstart

Integration assistant

Manage

Branding & properties

Authentication

Certificates & secrets

Token configuration

API permissions

i The "Admin consent required" column shows the default value for user, or app. This column may not reflect the value in your o

Configured permissions

Applications are authorized to call APIs when they are granted permissions should include all the permissions the application

+ Add a permission ✓ Grant admin consent for rbspm

API / Permissions name	Type	Description
v Microsoft Graph (1)		

Select an API

Microsoft APIs
APIs my organization uses
My APIs

Commonly used Microsoft APIs

Microsoft Graph

Take advantage of the tremendous amount of data in Office 365, Enterprise Mobility + Security, and Windows 10. Access Azure AD, Excel, Intune, Outlook/Exchange, OneDrive, OneNote, SharePoint, Planner, and more through a single endpoint.

Request API permissions ✕

[All APIs](#)

Microsoft Graph
<https://graph.microsoft.com/> [Docs](#)

What type of permissions does your application require?

Delegated permissions

Your application needs to access the API as the signed-in user.

Application permissions

Your application runs as a background service or daemon without a signed-in user.

Select the following 5 permissions.

- ◆ Calendar permissions:
 - ◆ Calendars.Read
 - ◆ Calendars.ReabBasic.All
 - ◆ Calendars.ReadWrite
- ◆ Place permission:
 - ◆ Place.Read.All
- ◆ User permission:
 - ◆ User.Read.All

And then click **Add permissions**.

Request API permissions ×

Delegated permissions
Your application needs to access the API as the signed-in user.

Application permissions
Your application runs as a background service or daemon without a signed-in user.

Select permissions [collapse all](#)

calendar ×

Permission	Admin consent required
<p>▼ Calendars (3)</p>	
<input checked="" type="checkbox"/> Calendars.Read ⓘ Read calendars in all mailboxes	Yes
<input checked="" type="checkbox"/> Calendars.ReadBasic.All ⓘ Read basic details of calendars in all mailboxes	Yes
<input checked="" type="checkbox"/> Calendars.ReadWrite ⓘ Read and write calendars in all mailboxes	Yes

Add permissions

Discard

Click **Grant admin consent for your account**, as illustrated below, and then click **Yes** to finish.

+ Add a permission ✔ Grant admin consent for rbspm

API / Permissions na...	Type	Description	Admin consent req...	Status
▼ Microsoft Graph (7)				
Calendars.Read	Delegated	Read user calendars	No	✔ Granted for rbspm
Calendars.Read.Sha	Delegated	Read user and shared calendars	No	✔ Granted for rbspm

Grant admin consent confirmation.

Do you want to grant consent for the requested permissions for all accounts in aten3562? This will update any existing admin consent records this below.

Setting Up Microsoft 365 in ATEN RBS Configurator

Account Settings

1. On your RBS Configurator, go to **Calendar Settings > Microsoft 365** and enter the Microsoft 365 Calendar related settings, as below.

Microsoft 365

Specify the delegated account you created for the resource rooms.

Authentication Method

Delegate Account

Delegate Password

Application ID

Room Grouping

2. Select an authentication method.
3. Fill in the following fields. Depending on the selected authentication method, different information needs to be provided.
 - ◆ **Account Credentials**
 - ◆ **Delegate Account:** Enter the name of the delegate assign to resource account created the Microsoft 365 Calendar’s delegate account.
 - ◆ **Delegate Password:** Enter the password of the Microsoft 365 Calendar’s delegate account.
 - ◆ **Application ID:** Enter the application ID of the ATEN Room Booking System as registered in the Microsoft Entra (page 65).
 - ◆ **Client Secret Key**

The following information is obtained by registering the application in Microsoft Entra. For full details, see *Registering the Application*, page 70.

- ◆ **Application ID:** Enter the application ID of the ATEN Room Booking System.
- ◆ **Tenant ID:** Enter the tenant (directory) ID.
- ◆ **Secret Code:** Enter the client secret code.

Configuring Room Grouping

Enable this function to refine the list of available rooms (shows up by tapping Suggest Room on RBS panels) by only showing rooms within a distribution group or domain.

1. Select a room grouping option.
 - a) On RBS Configurator, go to **Calendar Settings > Microsoft 365**.
 - b) Select **Display based on calendar server's settings** or **Display based on Unizon deployment tree's settings**.
 - ◆ **Room Grouping:** Enable this function to refine the list of available rooms (shows up by tapping Suggest Room on RBS panels) by only showing rooms within a distribution group or domain.
 - ◆ **Disable:** This is the default setting. With this setting, all available rooms can be shown, disregarding their physical location or distribution group.
 - ◆ **Display based on calendar server's settings:** displays available rooms that are in the same distribution group.
 - ◆ **Display based on Unizon deployment tree's settings:** displays available rooms within the third last level (e.g. building) and groups these rooms by the locations from the second last level (e.g. floor).

For example, the image below illustrates a Unizon deployment tree, the last level being the rooms, the second last are floors, and the third last are the cities. When operating an RBS panel in Taiwan HQ to search for available rooms (using the Suggest Room function), all the available rooms in Taiwan HQ (third last level) will be listed by floor (second last level), and a drop-down list of floors will be available for uses to switch.

If you have selected **Display based on Unizon's deployment tree's settings**, go to Unizon and make sure the second and third last levels are clearly named. For more information please refer the to *Unizon user manual*.

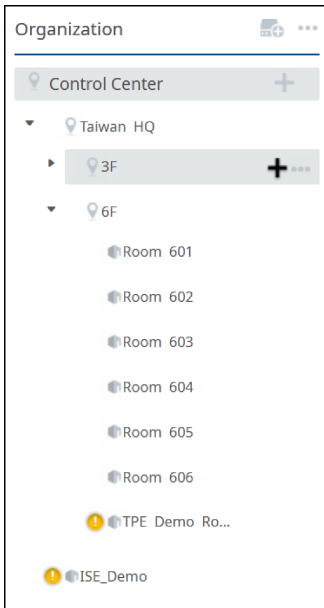

2. If you have selected **Display based on calendar server's settings**, create and/or configure distribution groups using PowerShell.
 - a) Connect to **PowerShell** and make sure the *Administrator: Windows PowerShell* appears in the title bar. If *Windows PowerShell* appears in the title bar instead, right-click on the **PowerShell** icon in the bottom bar and then click **Run as Administrator**.
 - b) Copy and paste the text `Set-ExecutionPolicy RemoteSigned` to change the execution policy setting.
 - c) Type **Y** to agree changing the execution policy. Copy and paste the text `[Net.ServicePointManager]::SecurityProtocol=[Net.SecurityProtocolType]::Tls12` to set security protocol.
 - d) Copy and paste the text `Install-Module-Name ExchangeOnlineManagement` to install Exchange Online Module.
 - e) Type **Y** to accept installing the module.
 - f) Copy and paste the text `Import-Module ExchangeOnlineManagement` to use Exchange Online Module.

- g) Copy and paste the text `Connect-ExchangeOnline` to log in to the Exchange Online from the pop-up window by using admin account and password.
- h) Create distribution groups and put rooms into distribution groups using the following commands.

Configuration Action	Command
To create a new distribution group	<p><code>New-DistributionGroup roomlist -RoomList</code></p> <p>Note: <code>roomlist</code> is an example name of the new distribution group.</p>
To put rooms into a distribution group	<p><code>Add-DistributionGroupMember -Identity "roomlist" -Member room account</code></p> <p>Note: <code>roomlist</code> and <code>room account</code> are example names of the target distribution group and room account.</p>

- i) Add floor information to each room.

Configuration Action	Command
To add floor information to a room	<p><code>Set-Place room account -Floor x -FloorLabel "characters and numbers"</code></p> <p>Note: Put the name of the floor label in the quotation marks. <code>"characters and numbers"</code> is used as an example here.</p>
To check floor information	<code>Get-Place room account FL</code>

- j) (Optional) Additional commands are available, please see the table below for details.

Configuration Action	Command
To remove a distribution group	<p><code>Remove-DistributionGroup "roomlist"</code></p> <p>Note: Put the name of the distribution group in the quotation marks. <code>"roomlist"</code> is used as an example here.</p>
To see created distribution groups	<code>Get-DistributionGroup</code>

Configuration Action	Command
To see created rooms in a distribution group	<pre>Get-DistributionGroupMember -Identity "roomlist"</pre> <p>Note: Put the name of the distribution group in the quotation marks. "roomlist" is used as an example here.</p>
To remove a room account from a distribution group	<pre>Remove-DistributionGroupMember -Identity "roomlist" -Member room account</pre> <p>Note: roomlist and room account are example names of the target distribution group and room account.</p>

-
- Note:** 1. The calendar server may take up to 24 hours for the changes to take effect.
2. Room lists can also be used as floor filters when searching for available rooms using the Suggest Room function on RBS panels, that is, only rooms within the same room list (distribution group) appear are suggested by the Room Booking System.
-

Microsoft Exchange Server

Setup Overview

To use Microsoft Exchange Server to manage ATEN room booking system, complete the following setup.

No.	Microsoft Exchange Server	
	2013, 2016, 2019 Version	2010 Version
1	Check the version of your Microsoft Exchange server (page 82).	
2	Find the host name (page 84).	Find the host name (page 99).
3	Create a room mailbox (page 87).	Create a room mailbox (page 102).
4	Add the room mailbox to a distribution group (page 89).	Add the room mailbox to a distribution group (page 104).
5	Decide an authentication method and complete the required setup (page 93).	Decide an authentication method and complete the required setup (page 107).
6	To use account credentials for authentication, create a delegate mailbox (page 94).	To use account credentials for authentication, create a delegate mailbox (page 107).
7	<ul style="list-style-type: none"> ◆ To use <i>account credentials</i> for authentication, reset the room password (page 93). ◆ To <i>impersonate account rights</i>, configure impersonation rights (page 96). 	<ul style="list-style-type: none"> ◆ To use <i>account credentials</i> for authentication, reset the room password (page 109). ◆ To <i>impersonate account rights</i>, configure impersonation rights (page 112).
8	Configure the account settings and room grouping in ATEN RBS Configurator (page 113).	

Checking the Version of Your Microsoft Exchange Server

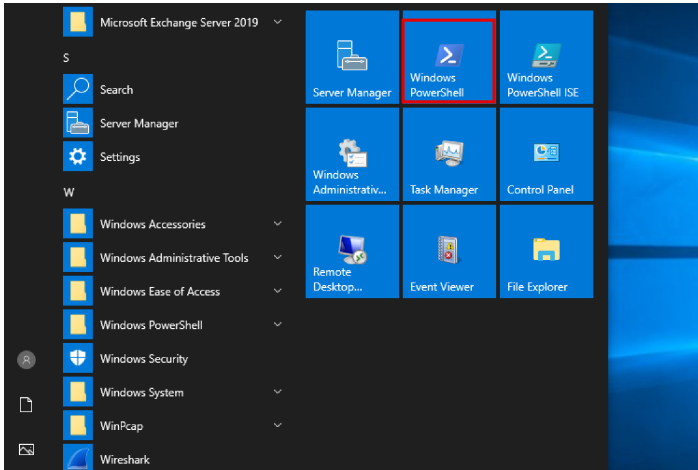
1. Open **Windows PowerShell** from the Start menu.2. Input the command below to check the returned **FileVersion** number:

```
Get-Command Exsetup.exe | ForEach {$_.FileVersionInfo}
```

 A screenshot of a Windows PowerShell terminal window titled 'Administrator: Windows PowerShell'. The terminal shows the command `Get-Command Exsetup.exe | ForEach {$_.FileVersionInfo}` being executed. The output is a table with three columns: 'ProductVersion', 'FileVersion', and 'FileName'. The 'FileVersion' value '15.02.0858.005' is highlighted with a red box. Below the table, the command `New-DistributionGroup -Name "RoomListTest" -RoomList` is also visible.

```

Administrator: Windows PowerShell
Windows PowerShell
Copyright (C) Microsoft Corporation. All rights reserved.

PS C:\Users\Administrator> Get-Command Exsetup.exe | ForEach {$_.FileVersionInfo}

ProductVersion FileVersion      FileName
-----
15.02.0858.005 15.02.0858.005 C:\Program Files\Microsoft\Exchange Server\V15\bin\ExSe...

PS C:\Users\Administrator> New-DistributionGroup -Name "RoomListTest" -RoomList
  
```

The number associated with “FileVersion” from the output (e.g. “15.02.0858.005” in the figure) is the build version of your Microsoft Exchange server. Determine which Microsoft Exchange version is installed on your computer from the table below.

Microsoft Exchange Version	Build Number
2010	14.03.xxxx.xxx
2013	15.00.xxxx.xxx
2016	15.01.xxxx.xxx
2019	15.02.xxxx.xxx

Microsoft Exchange 2013 / 2016 / 2019

Follow the steps to set up your **Microsoft Exchange 2010** for managing your ATEN Room Booking System.

Finding the Host Name

- ◆ If you have *identical* computer name and certificate name, look up the host name as follows. If not, proceed to the next step.

(1) In Server Manager, go to **Local Server > Properties**. This screen appears. Note down the *host name* and *domain* to be used later for setting up the calendar server in RBS Configurator.

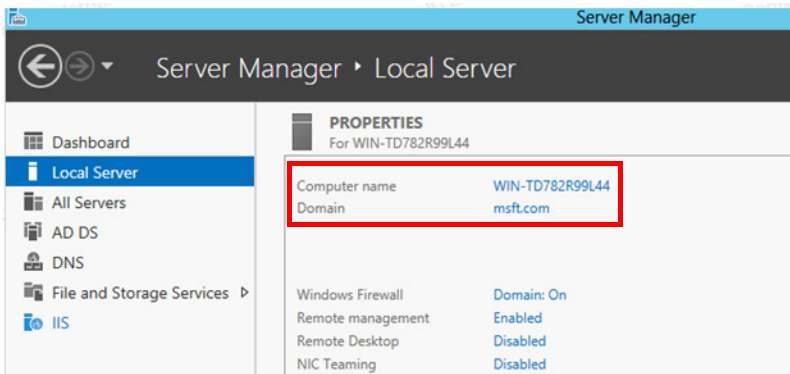

(2) In Windows PowerShell, execute the `ipconfig` command to look up the IP address of the Exchange server. Note down this IP address which will be needed when assigning a static IP address to RBS panels in RBS Configurator.

- ◆ If you have *different* computer name and certificate name, look up the host name as follows.
 - (1) In Server Manager, go to **Tools > Internet Information Service (IIS) Manager**.

(2) Under the Connections panel, click the computer name and **Default Web Site**, and in the Actions column, click **Bindings**.

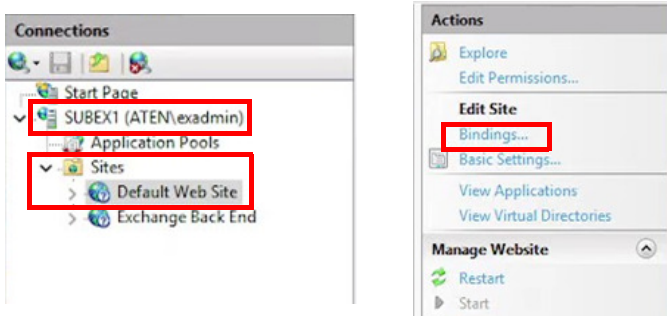

(3) In the pop-up dialog box, double-click https 443 for the local computer to find out the SSL certificate.

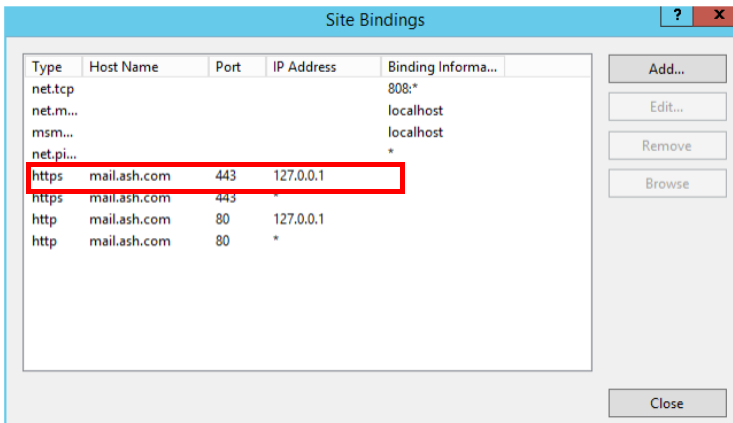

In this example, the SSL certificate is **twca2021**.

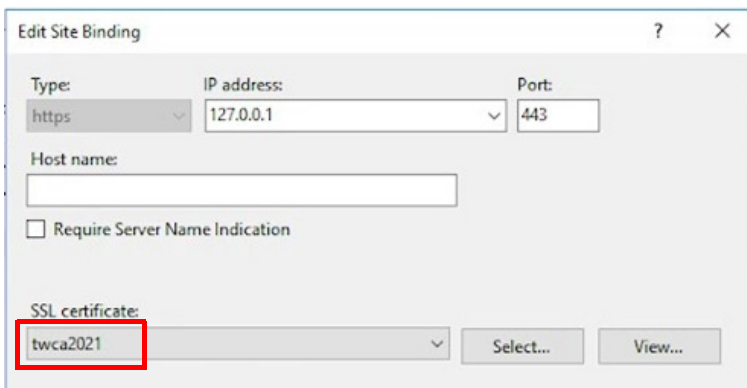

(4) In the Internet Information Service screen, click the computer name from the Connections panel. and then double-click **Server Certificate**.

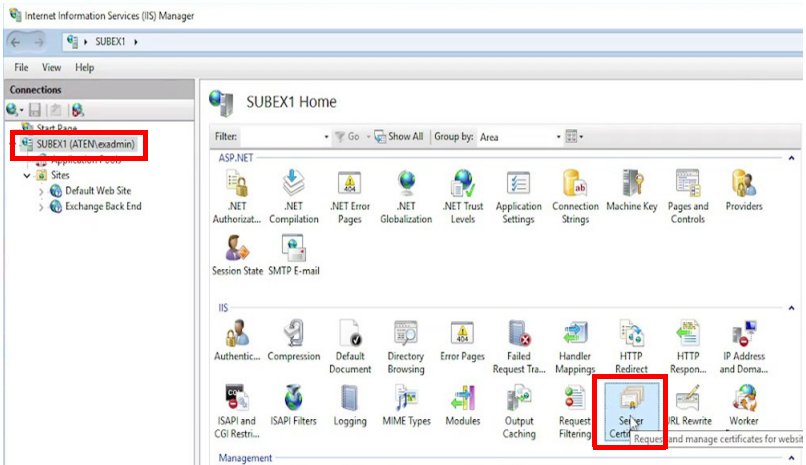

All host names are listed in the Issued To column. In this example, the host name for **twca2021** is **mail.aten.com**.

Server Certificates

Use this feature to request and manage certificates that the Web server can use with websites configured for SSL.

Name	Issued To	Issued By	Expiration Date	Certificate Has
ATEN	*.aten.com	TWCA Secure SSL Certificatio...	6/24/2022 11:59:59...	4443C679F740i
ATEN2022	*.aten.com	TWCA Secure SSL Certificatio...	6/24/2023 11:59:59...	A3C096B3D86i
Microsoft Exchange	SubEX1	SubEX1	11/17/2025 9:49:03...	060AF796A009
Microsoft Exchange 2022	mail.aten.com	mail.aten.com	6/1/2027 2:24:22 PM	B21347BECB82
Microsoft Exchange Server Aut...	Microsoft Exchange Server Au...	Microsoft Exchange Server Au...	10/22/2025 9:51:52...	46291C490E1F
twca2021	mail.aten.com	TWCA Secure SSL Certificatio...	11/19/2022 11:59:5...	889ADA35969f
WMSVC-SHA2	WMSvc-SHA2-SUBEX1	WMSvc-SHA2-SUBEX1	11/15/2030 7:48:25...	0F86B71659AA

(5) Note down the host name to be used later for setting up the calendar server in RBS Configurator.

Creating a Room Mailbox

1. In **EAC**, go to **recipients > resources** and click **+**. This screen appears.

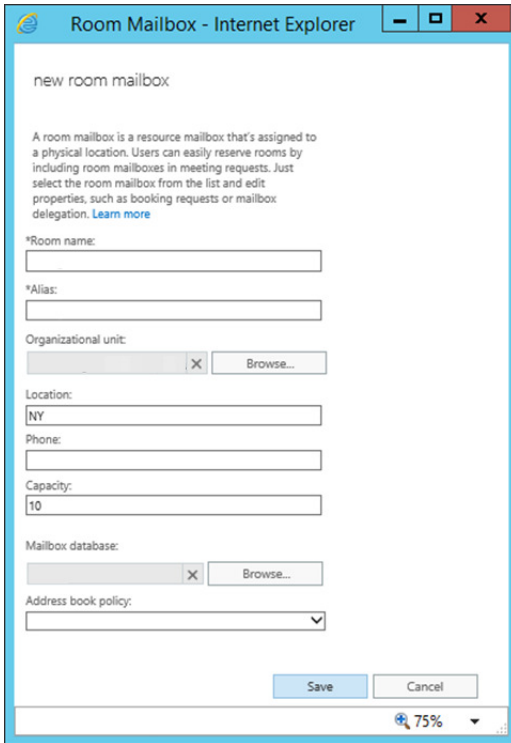

The screenshot shows a web browser window titled "Room Mailbox - Internet Explorer". The page content is as follows:

new room mailbox

A room mailbox is a resource mailbox that's assigned to a physical location. Users can easily reserve rooms by including room mailboxes in meeting requests. Just select the room mailbox from the list and edit properties, such as booking requests or mailbox delegation. [Learn more](#)

*Room name:

*Alias:

Organizational unit:

Location:

Phone:

Capacity:

Mailbox database:

Address book policy:

75%

2. Fill in the room name and alias.
3. Click **Save** to create the room mailbox.

- Double-click on the created room mailbox to set the delegates for accepting or declining the room booking requests.

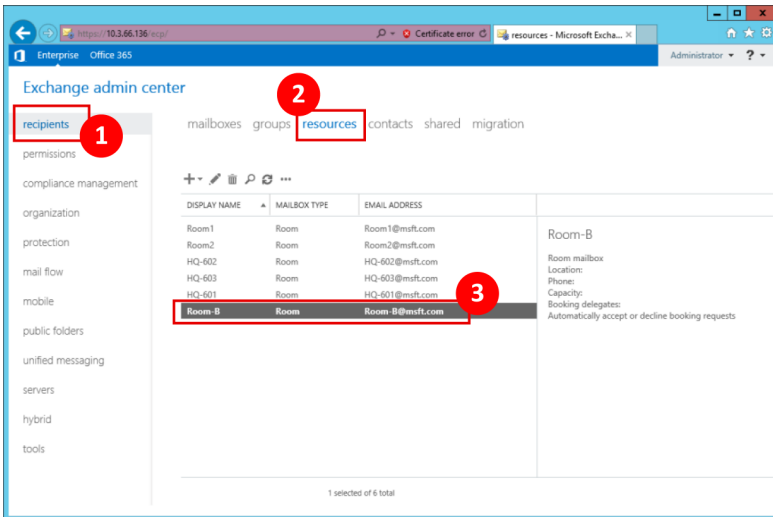

- In the pop-up, click the delegate to be added and then click the add button. Finish your configuration by clicking the **ok** button.

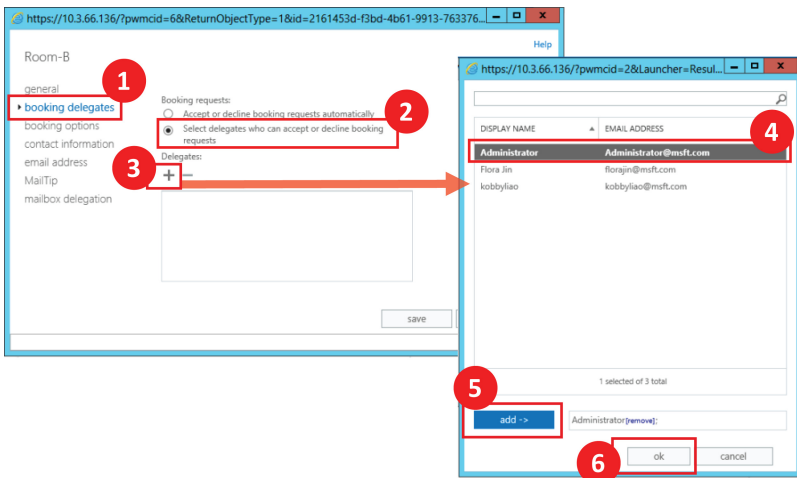

Adding the Room Mailbox to a Room List (Distribution Group)

1. Launch **Exchange Management Shell** from the **Start** menu.

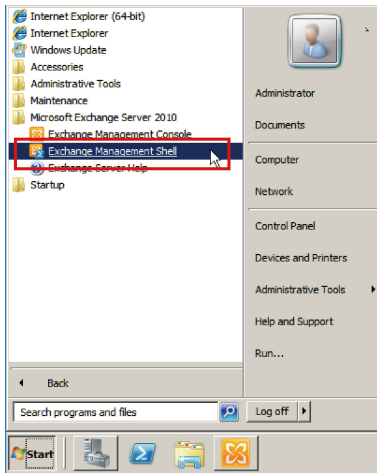

2. Run the command below to create a distribution group:
New-DistributionGroup -Name "ROOM LIST" -RoomList

```

Machine: WIN-IH09S013L03.msft.com

Only Exchange cmdlets:      get-excommand
Cmdlets for a specific role: get-help -role *UM* or *Mailbox*
Get general help:           help
Get help for a cmdlet:      help <cmdlet-name> or <cmdlet-name> -?
Show quick reference guide: quickref
Exchange team blog:         get-exblog
Show full output for a cmd: <cmd> ! format-list

Tip of the day #46:

Want to control the properties of e-mail messages sent to a specific domain? Use
the RemoteDomain cmdlets. Create a new remote domain by using the New-RemoteDom
ain cmdlet. Type:

New-RemoteDomain -Name "Contoso.com Configuration" -DomainName contoso.com

Then modify the properties that you want for this remote domain by using the Set
-RemoteDomain cmdlet:

Set-RemoteDomain "Contoso.com Configuration" -AutoReplyEnabled $True -AutoForwa
rdEnabled $True

VERBOSE: Connecting to WIN-IH09S013L03.msft.com
VERBOSE: Connected to WIN-IH09S013L03.msft.com.
[LPS] C:\Windows\system32>New-DistributionGroup -Name "forTesting" -RoomList
  
```

Note:

- ◆ **ROOM LIST** in the command is the name for the room list to be created, e.g., **forTesting** as the figure shows.
- ◆ Room lists can also be used as floor filters when searching for available rooms using the Suggest Room function on RBS panels, that is, only rooms within the same room list (distribution group) appear are suggested by the Room Booking System. For full setup information, see *Setting Up Room Grouping*, page 114.

The room list (distribution group) is successfully created.

```

Machine: WIN-IH09SQ13L03.msft.com

Tip of the day #46:
Want to control the properties of e-mail messages sent to a specific domain? Use
the RemoteDomain cmdlets. Create a new remote domain by using the New-RemoteDom
ain cmdlet. Type:

New-RemoteDomain -Name "Contoso.com Configuration" -DomainName contoso.com

Then modify the properties that you want for this remote domain by using the Set
-RemoteDomain cmdlet:

Set-RemoteDomain "Contoso.com Configuration" -AutoReplyEnabled $True -AutoForwa
rdEnabled $True

VERBOSE: Connecting to WIN-IH09SQ13L03.msft.com
VERBOSE: Connected to WIN-IH09SQ13L03.msft.com.
[PS] C:\Windows\system32>New-DistributionGroup -Name "forTesting" -RoomList

Name                DisplayName          GroupType            PrimarySmtppAddress
-----                -
forTesting          forTesting          Universal           forTesting@msft.com

[PS] C:\Windows\system32>
    
```

3. Use the cmdlet below to add your room mailbox to this room list:
 Add-DistributionGroupMember -Identity "ROOM LIST" -Member
 ROOM ACCOUNT

```

Machine: WIN-IH09SQ13L03.msft.com
Tip of the day #46:
Want to control the properties of e-mail messages sent to a specific domain? Use
the RemoteDomain cmdlets. Create a new remote domain by using the New-RemoteDom
ain cmdlet. Type:

New-RemoteDomain -Name "Contoso.com Configuration" -DomainName contoso.com

Then modify the properties that you want for this remote domain by using the Set
-RemoteDomain cmdlet:

Set-RemoteDomain "Contoso.com Configuration" -AutoReplyEnabled $True -AutoForwa
rdEnabled $True

VERBOSE: Connecting to WIN-IH09SQ13L03.msft.com
VERBOSE: Connected to WIN-IH09SQ13L03.msft.com.
[PS] C:\Windows\system32>New-DistributionGroup -Name "forTesting" -RoomList

Name                DisplayName          GroupType            PrimarySmtpAddress
----                -
forTesting          forTesting          Universal            forTesting@msft.com

[PS] C:\Windows\system32>Add-DistributionGroupMember -Identity "forTesting" -Mem
ber Room-A
  
```

Note:

- ◆ **Member ROOM ACCOUNT** here indicates the name of your room mailbox to be added, e.g., **Room-A** as the figure shows.
- ◆ Repeat Step 4 to add more room mailboxes to the room list.
- ◆ Each room list can contain up to 100 rooms.

- To check whether the room mailbox(es) is successfully added to the room list, use the cmdlet below and see the returned room list member(s).

`Get-DistributionGroupMember -Identity "ROOM LIST"`

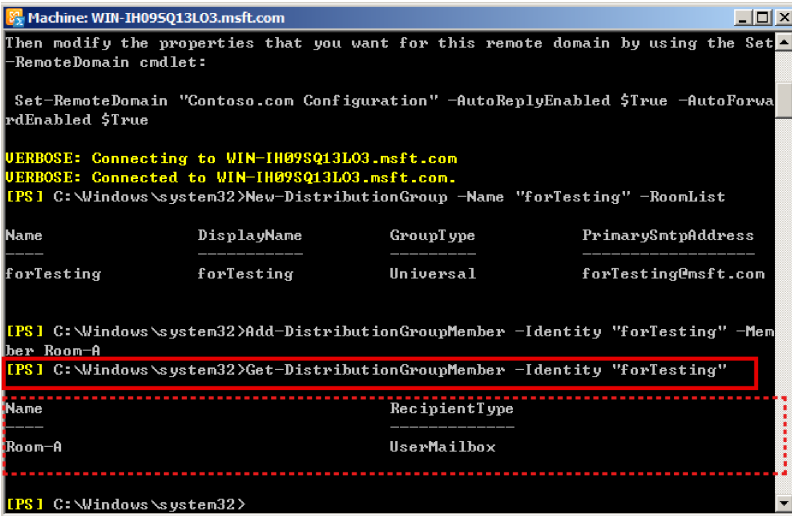

You may use the following commands to check the current setup:

- To see the created distribution groups:

`Get-DistributionGroup`

For example, a list similar to the following appears:

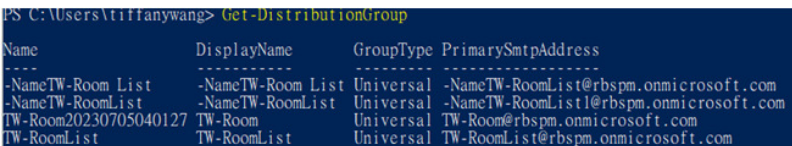

- To remove a certain distribution group:

`Remove-DistributionGroup "Meeting Rooms"`

Press [Y] to confirm the change. The distribution group named **Meeting Rooms** will be removed.

- To see all rooms within a distribution group:

`Get-DistributionGroupMemeber -Identity "TW-RoomList"`

For example:

```
PS C:\Users\tiffanywang> Get-DistributionGroupMember -Identity "TW-RoomList"
Name      RecipientType
-----
TW-Room1  UserMailbox
TW-Room3  UserMailbox
TW-Room2  UserMailbox
```

The rooms in the distribution group named [TW-RoomList](#) are listed.

- ◆ To remove a certain room account from a distribution group:
`Remove-DistributionGroupMember -Identity "distributiongroup" -Member Room account`
 Press **[Y]** to confirm the change. The room named [Room account](#) will be removed.

Deciding the Authentication Method

Decide how you wish to authenticate the calendar server, either through account credentials, or to impersonate account rights to the delegate. For a comparison of the pros and cons of the two methods, take a look of the following table.

	Using Account Credentials	Impersonate Account Rights
Pros	Flexible setup on different delegates for different resource accounts	<ul style="list-style-type: none"> ◆ No need to provide the resource account password ◆ Flexible for different network environment
Cons	Resource account password is needed for each room.	Limited number of simultaneous connections to RBS panels

Creating a Delegate Mailbox

To use account credentials for authentication, follow the procedure below to create a delegate mailbox.

1. Log in the Exchange Admin Center (EAC) with administrator credentials. You can use any of the following URL format to access EAC:

https://<IP address of your Exchange server>/ecp

https://<host name of your Exchange server>/ecp

For details on obtaining the URL of your EAC, see *ATEN Warranty Policy*, page 200.

2. Go to **Recipients > mailboxes**, and click +. This screen appears.

The screenshot shows a web browser window titled "User Mailbox - Google Chrome" with the URL "mail.aten.com/ecp/UsersGroups/NewMailboxOnPremises.aspx?p...". The page content is titled "new user mailbox". The form includes the following fields and elements:

- Initials: KR-RBSetup
- Initials: [Empty text box]
- Last name: [Empty text box]
- *Display name: KR-RBSetup
- *Name: KR-RBSetup
- Organizational unit: [Empty text box] with a "Browse..." button
- *User logon name: KR-RBSetup @ aten.co.kr (dropdown menu)
- *New password: [Masked password field]
- *Confirm password: [Masked password field]
- Require password change on next logon
- More options...
- Save and Cancel buttons

A tooltip is visible over the "Confirm password" field, containing the text: "Retype the password to verify that you typed it correctly."

3. Fill in the information to create a delegate mailbox.
4. Note down this mailbox address and the password to be used later for setting up the calendar server in RBS Configurator.

Resetting Room Password

If you would like to use account credentials for authentication, follow the procedure below to reset the room password. If you choose to grant account rights, skip this procedure and proceed directly to configure impersonation rights instead. For a suggested procedure, see *Configuring Impersonation Rights*, page 96.

1. In Server Manager, go to **Tools > Active Directory Administrator Center**.
2. In the pop-up screen, click **Users** from the left column.
3. Click on the room mailbox you created, click **Reset password**, and then follow the on-screen instructions to reset the password.

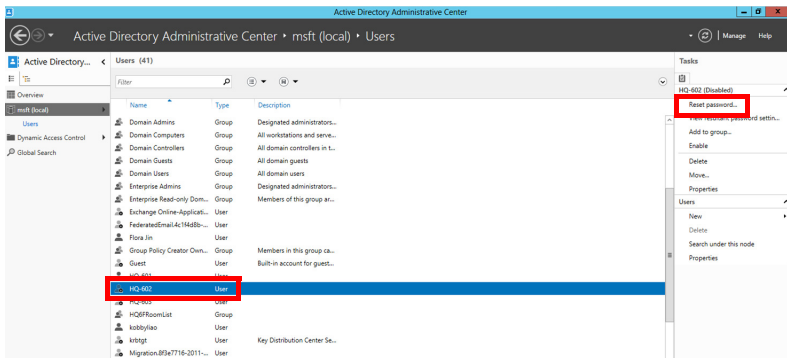

4. Click **Enable** to apply the configuration.

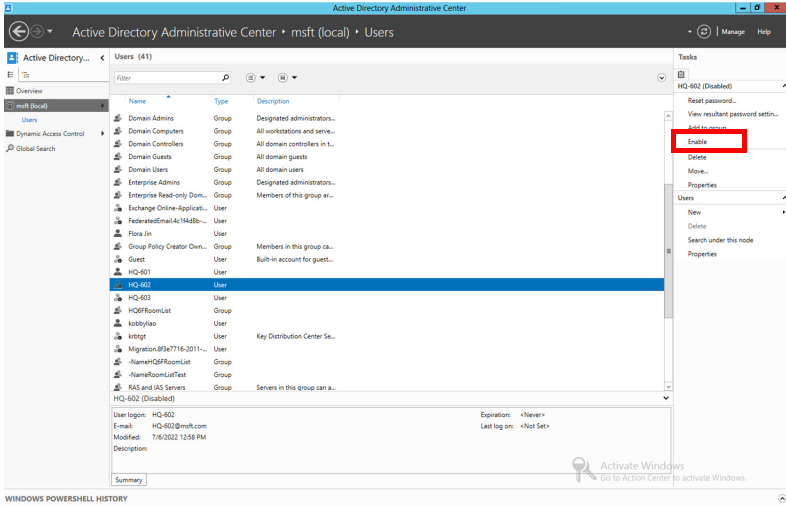

Configuring Impersonation Rights

If you would like to impersonate account rights, follow the procedure below. If you choose to use account credentials for authentication, reset the room password. For full details, see *Deciding the Authentication Method*, page 93.

1. Launch Exchange Management Shell. The Start screen and the way to open the program may differ for different OS versions.

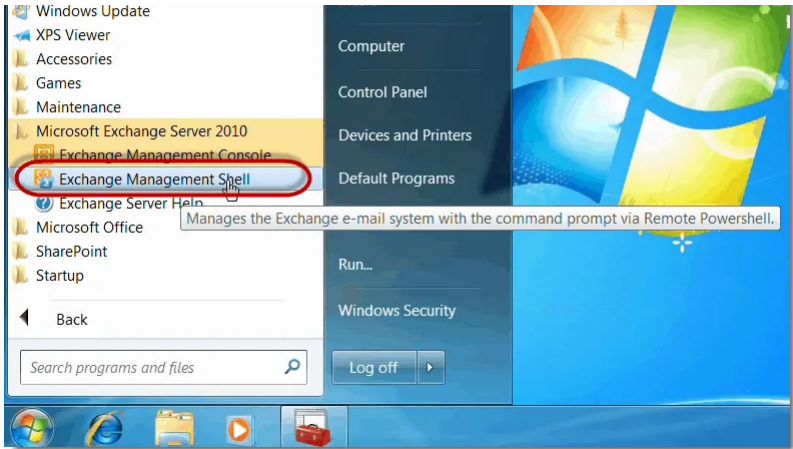

- Execute the following command to create a management scope.

Note: Put the name of the resource mailbox in the quotation marks.
 "ResourceMailboxes" is used as an example here.

```
New-ManagementScope -Name "ResourceMailboxes" -
RecipientRestrictionFilter { RecipientTypeDetails -eq
"RoomMailbox" -or RecipientTypeDetails -eq
"EquipmentMailbox" }
```

- Execute the following command to grant impersonation rights.

Note:

- Put the name of the resource impersonation in the quotation marks.
 "ResourceImpersonation" is used as an example here.
 - delegate@xxxx.com is the delegate account that you have created.
-

```
New-ManagementRoleAssignment -Name "ResourceImpersonation"
-Role ApplicationImpersonation -User delegate@xxxx.com -
CustomRecipientWriteScope "ResourceMailboxes"
```

- Check if impersonation rights are successfully given by executing the following command.

Get-ManagementRoleAssignment -Role

“ApplicationImpersonation” -GetEffectiveUsers

The role column should be indicated with ApplicationImpersonation, and EffectiveUsername column should indicate the name of the delegate account.

Microsoft Exchange 2010

Follow the steps to set up your **Microsoft Exchange 2010** for managing your ATEN Room Booking System.

Finding the Host Name

- ◆ If you have *identical* computer name and certificate name, look up the host name as follows. If not, proceed to the next step.

(1) In Server Manager, go to **Local Server > Properties**. Note down the *host name* and *domain* to be used later for setting up the calendar server in RBS Configurator.

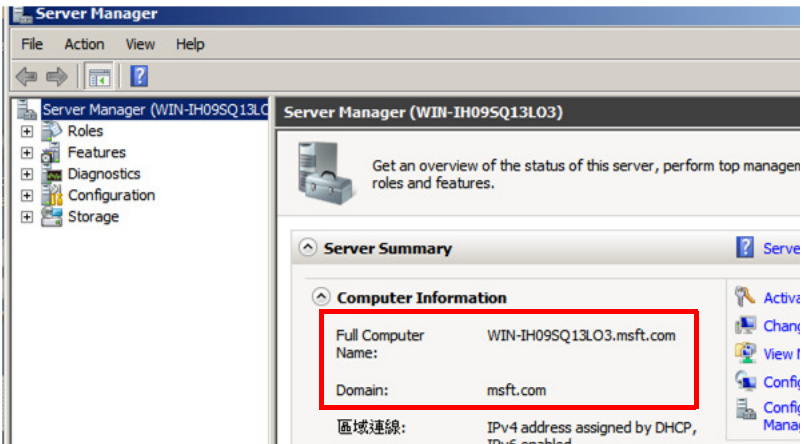

(2) In Windows PowerShell, execute the `ipconfig` command to look up the IP address of the Exchange server. Note down this IP address when you need to assign a static IP address to RBS panels in RBS Configurator.

```
Administrator: Windows PowerShell
Windows PowerShell
Copyright (C) 2009 Microsoft Corporation. All rights reserved.

PS C:\Users\administrator> ipconfig

Windows IP Configuration

Ethernet adapter 区域連線:

    Connection-specific DNS Suffix . : aten.com
    Link-local IPv6 Address . . . . . : fe80::c012:c4b6:a159:f66a%11
    IPv4 Address. . . . . : 10.3.66.114
    Subnet Mask . . . . . : 255.255.255.0
    Default Gateway . . . . . : 10.3.66.254

Tunnel adapter isatap.aten.com:
```

- If you have *different* computer name and certificate name, look up the host name as follows.

(1) In Server Manager, go to **Roles > Web Server (IIS) > Internet Information Service > computer name**, and double-click on Server Certificates.

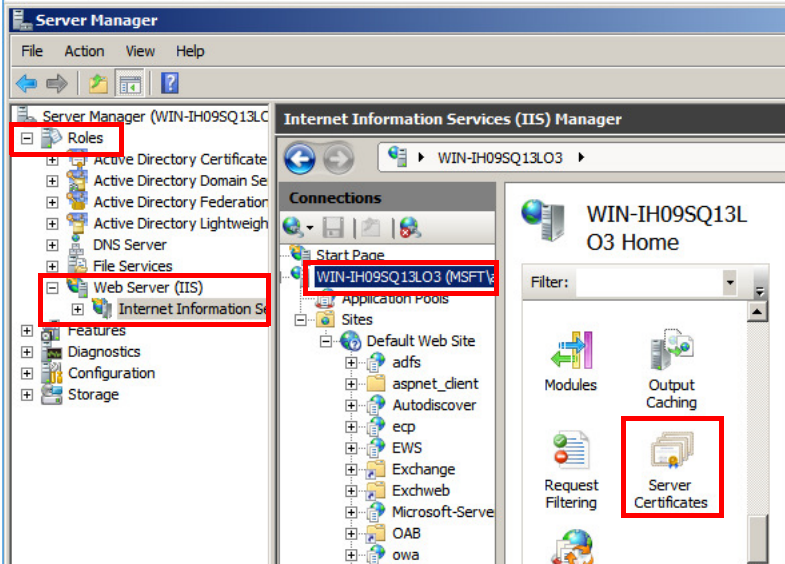

(2) In the pop-up window, double-click on **Microsoft Exchange**.

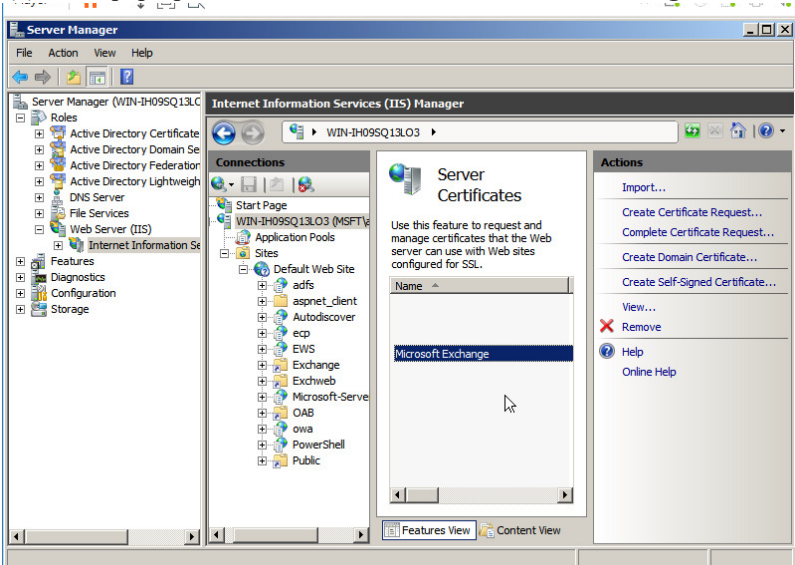

The following screen appears. The host name is indicated under the Issued to field.



(3) Note down the *host name* to be used later for setting up the calendar server in RBS Configurator.

Creating a Room Mailbox

1. In Exchange Management Console, navigate to **Recipient Configuration** > **Mailboxes**, right-click on **Mailboxes** to open the context menu, and select **New Mailbox**.

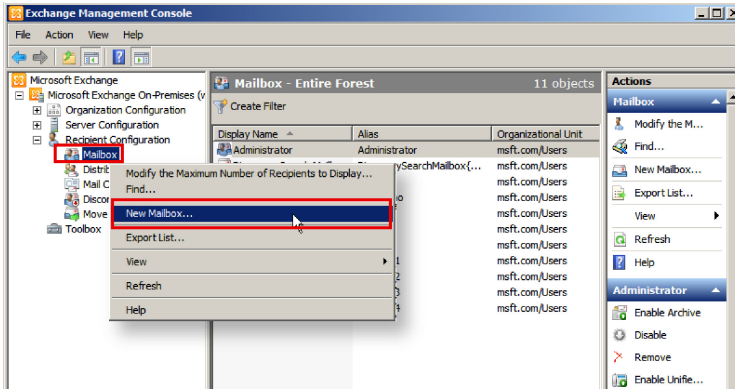

2. In the pop-up window, select **Room Mailbox** and click **Next**.

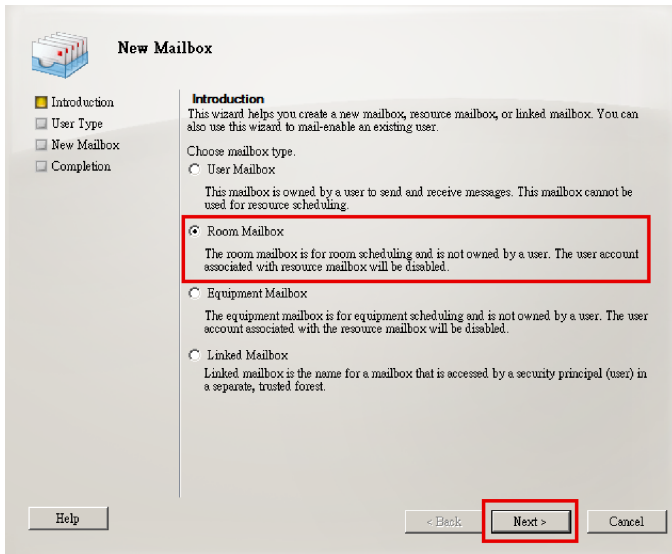

This screen appears. Note down the indicated mailbox address to be used for configuration later.

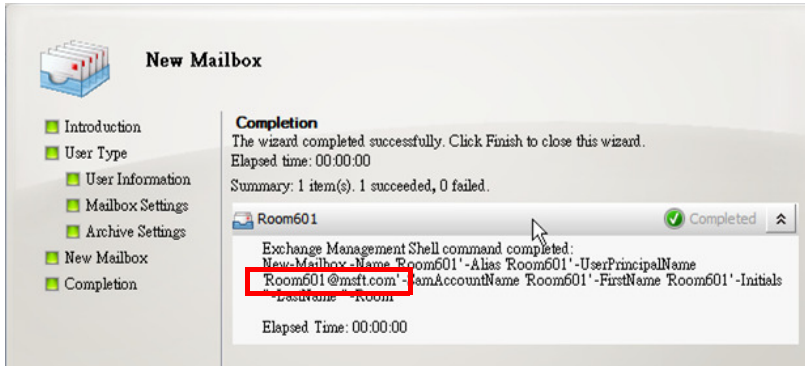

3. In the mailbox list, right-click on the created mailbox, and click **Properties**.
4. Click the **Resource Policy** tab, click **+Add**, and follow the on-screen instructions to add a delegate.
5. In Server Manager, go to **Roles > Active Directory Domain Services > Active Directory Users and Computers > Domain > Users**.
6. From the listed users, locate and right-click on the room, and then select **Enable Account**.
7. This created mailbox address and password are the resource account credentials for the Room Booking System. Save this information to be used later when configuring RBS panel settings in RBS Configurator.

Adding the Room Mailbox to a Room Distribution Group

1. Launch the **Exchange Management Shell** from the **Start** menu.

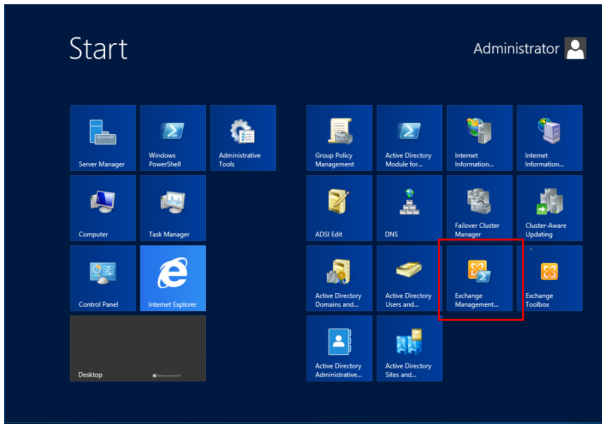

Note: The appearance of the Start menu is different with each Windows version.

2. Use the cmdlet below to create a new distribution group.

`New-DistributionGroup -Name "ROOM LIST" -RoomList`

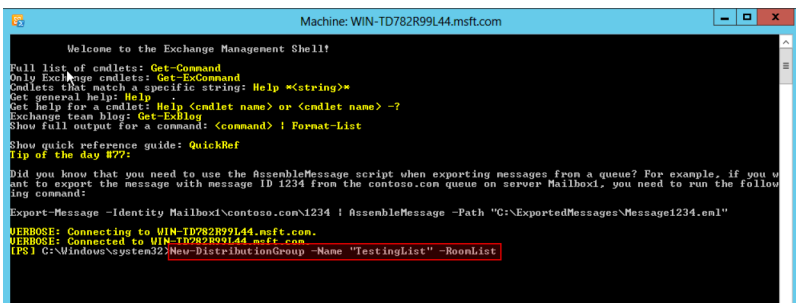

Note:

- ◆ **Room List** in the cmdlet indicates the name for the room list you are going to create. Please configure your own room list name.
- ◆ Room lists can also be used as floor filters when searching for available rooms using the Suggest Room function on RBS panels, that is, only rooms within the same room list (distribution group) appear as suggested by the Room Booking System. For full setup information, see *Setting Up Room Grouping*, page 114.

- Enter the cmdlet below to add the room mailbox into the room list:

```
Add-DistributionGroupMember -Identity "ROOM LIST" -Member
ROOM ACCOUNT
```

```
Machine: WIN-TD782R99L44.msft.com

Welcome to the Exchange Management Shell!

Full list of cmdlets: Get-Command
Only Exchange cmdlets: Get-ExchangeCommand
Cmdlets that match a specific string: Help *string*
Get general help: Help
Get help for a cmdlet: Help <cmdlet name> or <cmdlet name> -?
Exchange team blog: Get-ExBlog
Show full output for a command: <command> | Format-List

Show quick reference guide: QuickRef
Tip of the day #77:
Did you know that you need to use the AssembleMessage script when exporting messages from a queue? For example, if
you want to export the message with message ID 1234 from the contoso.com queue on server Mailbox1, you need to run the f
ollowing command:
Export-Message -Identity Mailbox1\contoso.com\1234 | AssembleMessage -Path "C:\ExportedMessages\Message1234.en1"

VERBOSE: Connecting to WIN-TD782R99L44.msft.com.
VERBOSE: Connected to WIN-TD782R99L44.msft.com.
[PS] C:\Windows\system32>New-DistributionGroup -Name "TestingList" -RoomList

Name                DisplayName                GroupType                PrimarySMTPAddress
-----                -
TestingList         TestingList                Universal                TestingList@msft.com

[PS] C:\Windows\system32>Add-DistributionGroupMember -Identity "TestingList" -Member Room-B.
```

Note:

- ROOM LIST in the cmdlet indicates the name of your room list, and ROOM ACCOUNT means the room mailbox to be added to the aforementioned room list.
 - Repeat this step to add more room mailboxes into the room list.
 - Each room list can contain up to 100 rooms.
- To check which room mailbox(es) is in the room list, enter the cmdlet below to get the output list:

```
Get-DistributionGroupMember -Identity "ROOM LIST"
```

```
Machine: WIN-TD782R99L44.msft.com

[PS] C:\Windows\system32>Get-DistributionGroupMember -Identity "TestingList"

Name                RecipientType
----                -
Room-B              UserMailbox

[PS] C:\Windows\system32>
```

Note: ROOM LIST in the cmdlet indicates the name of the room list you are going to check.

You may use the following commands to check the current setup:

- ◆ To see the created distribution groups:

`Get-DistributionGroup`

For example, a list similar to the following appears:

```
PS C:\Users\tiffanywang> Get-DistributionGroup
Name                DisplayName          GroupType PrimarySmtpAddress
-----
-NameTW-Room List  -NameTW-Room List  Universal -NameTW-RoomList@rbspm.onmicrosoft.com
-NameTW-RoomList   -NameTW-RoomList   Universal -NameTW-RoomList@rbspm.onmicrosoft.com
TW-Room20230705040127 TW-Room            Universal TW-Room@rbspm.onmicrosoft.com
TW-RoomList        TW-RoomList        Universal TW-RoomList@rbspm.onmicrosoft.com
```

- ◆ To remove a certain distribution group:

`Remove-DistributionGroup "Meeting Rooms"`

Press [Y] to confirm the change. The distribution group named **Meeting Rooms** will be removed.

- ◆ To see all rooms within a distribution group:

`Get-DistributionGroupMemeber -Identity "TW-RoomList"`

For example:

```
PS C:\Users\tiffanywang> Get-DistributionGroupMember -Identity "TW-RoomList"
Name      RecipientType
-----
TW-Room1  UserMailbox
TW-Room3  UserMailbox
TW-Room2  UserMailbox
```

The rooms in the distribution group named **TW-RoomList** are listed.

- ◆ To remove a certain room account from a distribution group:

`Remove-DistributionGroupMembr -Identity "distributiongroup" -Member Room account`

Press [Y] to confirm the change. The room named **Room account** will be removed.

5. Enter the cmdlet below to give full permission of the rooms to the delegate. Repeat this step for all rooms.

`Add-MailboxPermission -accessRights FullAccess -Identity ROOM NAME -User DELEGATE`

Deciding the Authentication Method

Decide how you wish to authenticate the calendar server, either through account credentials, or to impersonate account rights to the delegate. For a comparison of the pros and cons of the two methods, take a look of the following table.

	Using Account Credentials	Impersonate Account Rights
Pros	Flexible setup on different delegates for different resource accounts	<ul style="list-style-type: none"> ◆ No need to provide the resource account password ◆ Flexible for different network environment
Cons	Resource account password is needed for each room.	Limited number of simultaneous connections to RBS panels

Creating a Delegate Mailbox

To use account credentials for authentication, follow the procedure below to create a delegate mailbox.

1. Launch Exchange Management Console  from the **Start** menu.
2. Under Recipient Configuration, right-click on **Mailbox** and then select **New Mailbox**.

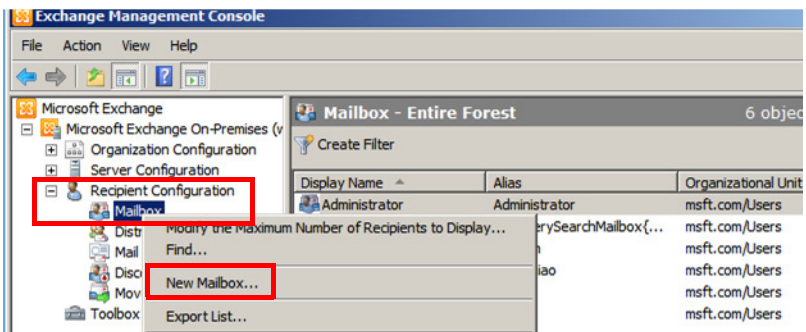

3. Select **User Mailbox**, and click **Next** to proceed.

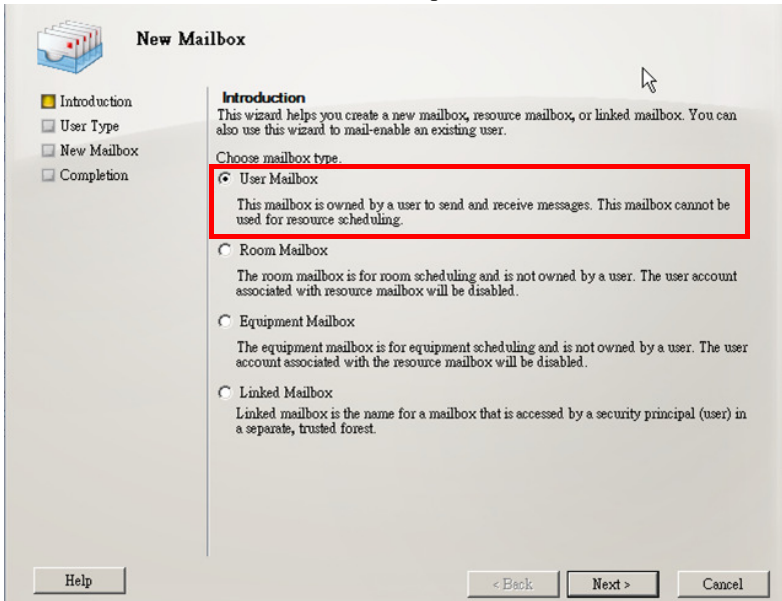

4. In the New Mailbox dialog box, fill in the information as indicated below.

5. Note down the *mailbox address* and the *password* to be used later for setting up the calendar server in RBS Configurator.

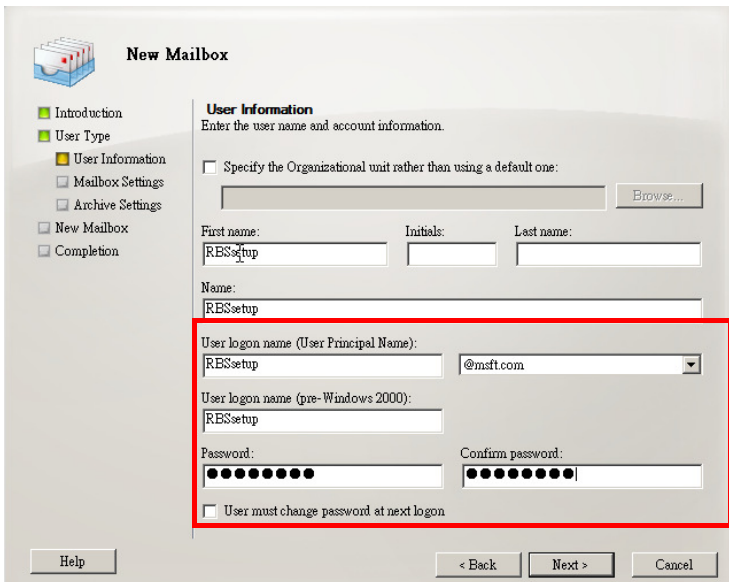

Setting up a Password for the Room Mailbox

If you would like to use account credentials for authentication, follow the procedure below to set up the password for the room mailbox. If you choose to grant account rights, skip this procedure and proceed directly to configure impersonation rights. For a detailed procedure, see *Configuring Impersonation Rights*, page 112.

1. Go to the **Start** menu > **All Programs** > **Administrative Tools** > **Server Manager**.

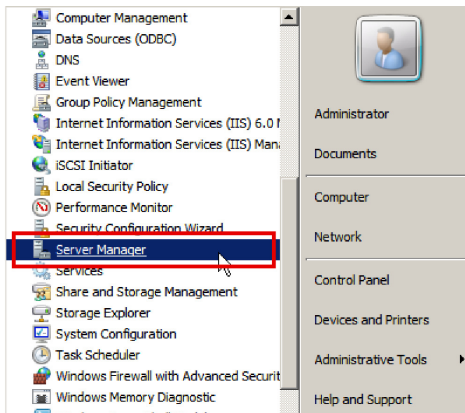

- In **Server Manager**, navigate to **Roles > Active Directory Domain Services > Active Directory Users and Computers > Domain > Users**.

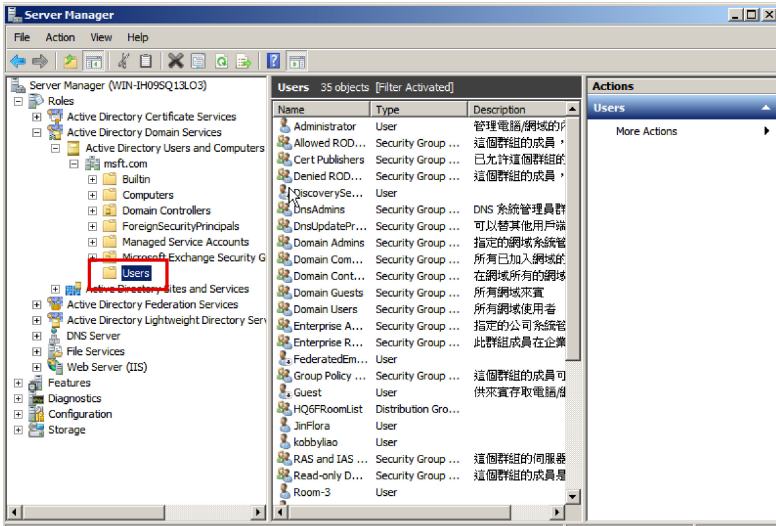

- Scroll to find the room mailbox you just created, right-click on it to open the context menu, and select the option **"Reset Password"**.

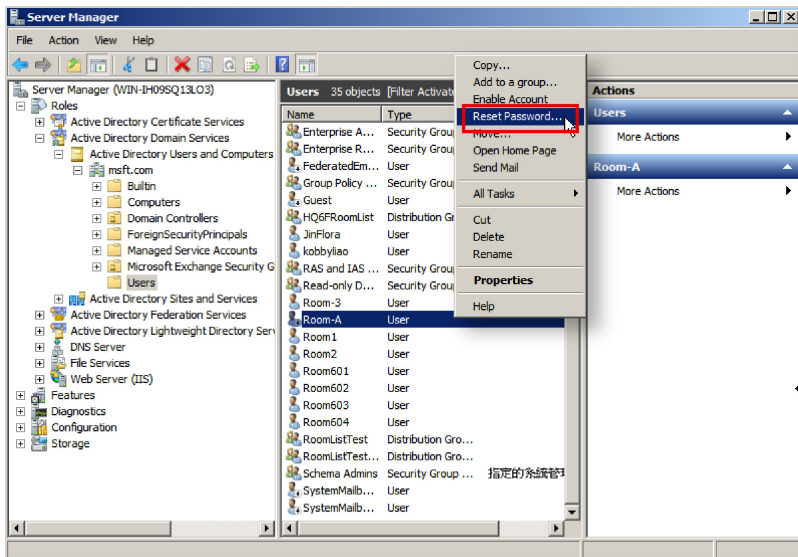

4. Enter and confirm the new password, and then click **OK** to reset it.

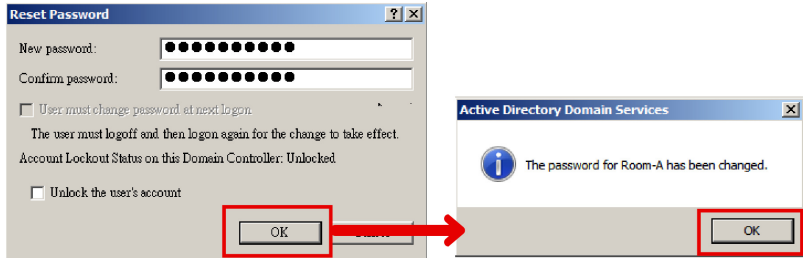

Note: Note down the new password that will be used for setting your ATEN RBS Configurator Panel Management. See the description about *Calendar Account*, page 165 in the section *Device Configuration Options*, page 164.

Configuring Impersonation Rights

1. Launch Exchange Management Console  from the **Start** menu.
2. Use the cmdlet below to create a manage scope.

```
New-ManagementScope -Name "ResourceMailboxes" -  
RecipientRestrictionFilter { RecipientTypeDetails -eq "RoomMailbox"  
-or RecipientTypeDetails -eq "EquipmentMailbox" }
```

Note: `ResourceMailboxes` is an example name for the management scope.

3. Use the cmdlet below to grant impersonation rights.

```
New-ManagementRoleAssignment -Name "ResourceImpersonation" -  
Role ApplicationImpersonation -User delegate@xxxx.com -  
CustomRecipientWriteScope "ResourceMailboxes"
```

Note: `ResourceImpersonation` is an example name for the management role assignment.

4. Execute the cmdlet below to check if impersonation rights are granted successfully.

```
Get-ManagementRoleAssignment -Role "ApplicationImpersonation" -  
GetEffectiveUsers
```

Note: Please make sure that in the Role column the value is ApplicationImpersonation, and in that same row under the EffectiveUsername is the name of delegate account.

Setting Up Microsoft Exchange in ATEN RBS Configurator

Account Settings

1. In RBS Configurator, go to **Calendar Settings > Exchange**. This page appears.

Exchange

Specify the delegated account you created for the resource rooms.

Authentication Method	account credentials <input type="button" value="v"/>
Host Name	<input type="text"/>
Delegate Account	<input type="text"/>
Delegate Password	<input type="text"/>
Domain	<input type="text"/>

Room Grouping	Disable <input type="button" value="v"/>
---------------	--

2. Select an authentication method.
3. Configure the following settings.
 - ♦ **Host Name:** Enter the Full Computer Name or Computer Name of your Exchange server. Check the computer name shown on **Server Manager**.
 - ♦ **Delegate Account:** Enter the address of the delegate mailbox that you created.
 - ♦ **Delegate Password:** Enter the password of your delegate account.
 - ♦ **Domain:** If your computer name and certificate name are the same, enter the Domain which can be checked in **Server Manager**. If you have different computer name and certificate name (for Microsoft Exchange 2013, 2016, 2019), or that your exchange server is of version 2010, leave this field blank.

Setting Up Room Grouping

Enable this function to refine the list of available rooms (shows up by tapping Suggest Room on RBS panels) by only showing rooms within a distribution group or domain.

1. Select a room grouping option.
 - a) On RBS Configurator, go to **Calendar Settings > Exchange**.
 - b) Select **Display based on calendar server's settings** or **Display based on Unizon deployment tree's settings**.
 - ◆ **Room Grouping:** Enable this function to refine the list of available rooms (shows up by tapping Suggest Room on RBS panels) by only showing rooms within a distribution group or domain.
 - ◆ **Disable:** This is the default setting.
 - ◆ **Display based on calendar server's settings:** displays available rooms that are in the same distribution group.
 - ◆ **Display based on Unizon deployment tree's settings:** displays available rooms within the third last level and groups these rooms by the locations from the second last level.

For example, the image below illustrates a Unizon deployment tree, the last level being the rooms, the second last are floors, and the third last are the cities. When operating an RBS panel in Taiwan HQ to search for available rooms (using the Suggest Room function), all the available rooms in Taiwan HQ (third last level) will be listed by floor (second last level), and a drop-down list of floors will be available for users to switch.

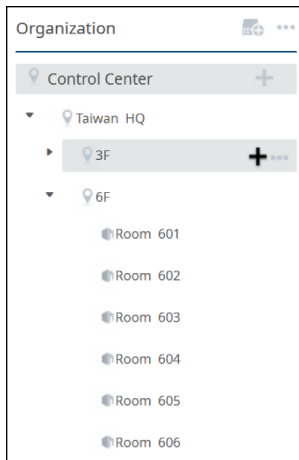

2. If you have selected **Display based on Unizon's deployment tree's settings**, go to Unizon and make sure the second and third last levels are clearly named.
3. If you have selected **Display based on calendar server's settings**, no further configuration is required.

Google Workspace

This section provides guidance on setting up Google Workspace for managing rooms via the ATEN room booking system.

Note:

The information and illustrations in this section are prone to change by the service provider, Google. For full and up-to-date information on Google Workspace, visit the corresponding online help for assistance.

Google Workspace Admin Help

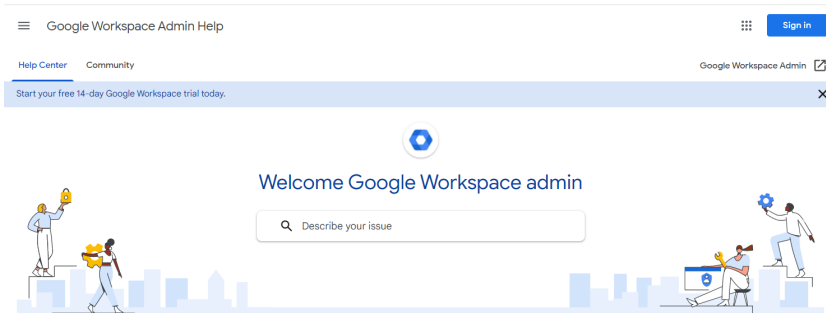

Google Cloud Platform Help

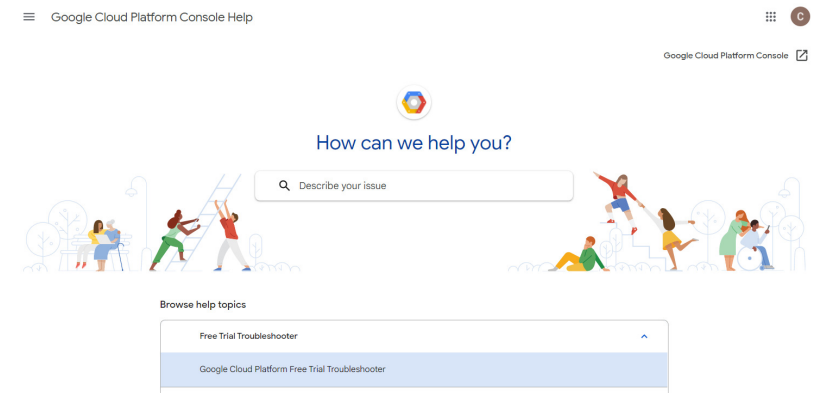

Setting Up Google Workspace for Room Management

1. Configure Google Workspace and the Cloud console.
2. On Google Admin console, add rooms and buildings you wish to manage via ATEN room booking system.
For a details, see *Adding Rooms, Buildings, and Users*, page 117.
3. Enable Google Calendar API and Admin API.
For details, see *Enabling Google Calendar and Admin API*, page 122.
4. Create a service account.
For details, see *Creating a Service Account*, page 124.
5. Allow access from third-party applications.
For details, see *Authorizing Access from Third-party Applications*, page 125.

Adding Rooms, Buildings, and Users

1. Sign in to Google Admin console via admin.google.com

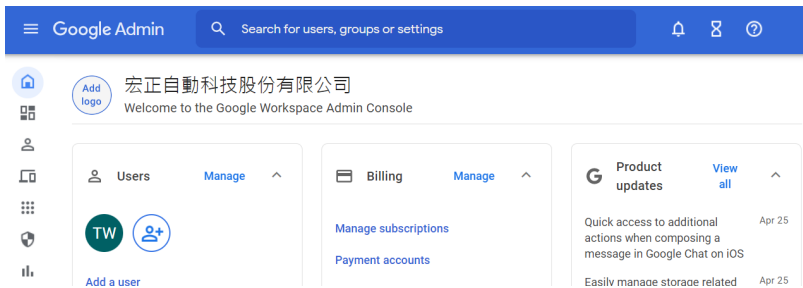

2. (Optional) Add accounts for people who will need to sign in to use Google Workspace services or configure its settings.

3. Add buildings.

- a) Mouse over to the left to expand the toolbar, and then go to **Directory > Buildings and resources > Manage resources > Manage Buildings**.

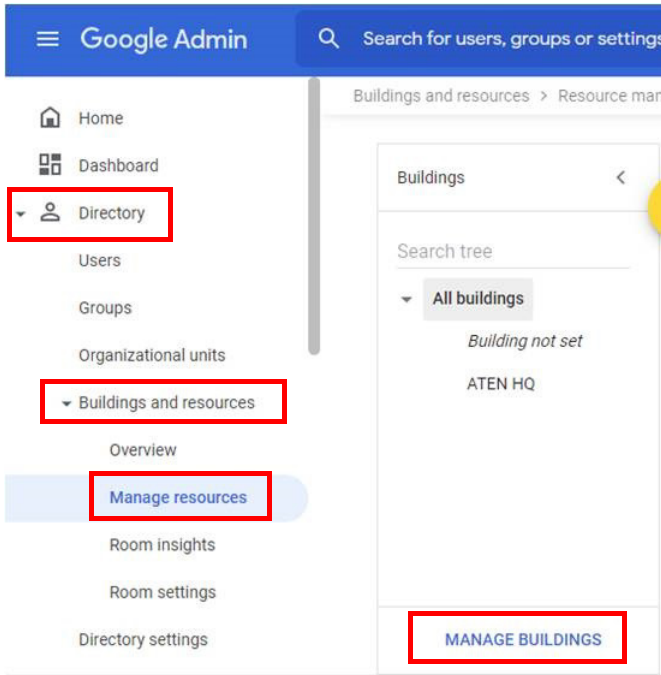

- b) Click + to add buildings.

Note: It is important to create buildings because buildings are used as a search filter when searching for available rooms on RBS panels using the Suggest Room function.

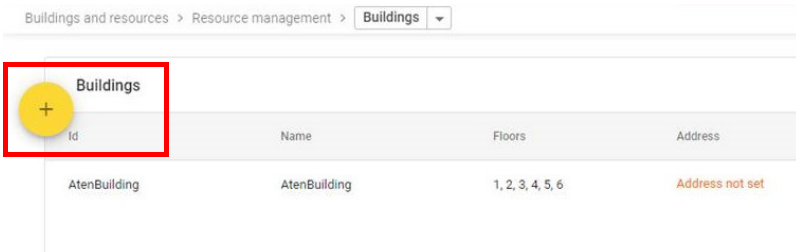

- c) In the pop-up dialog, enter the required information.

Note: Since floor names are used as search floor filters when searching for available rooms on RBS panels using the Suggest Room function, be sure to use names that are easy to understand.

Edit building

Id *
ATEN-HQ

Name *
ATEN HQ

Description

Floors *
3F, 4F, 5F, 6F

Address
No No, No. 125大同路二段智慧里, 汐止區, 新北市, 2
21, Taiwan

CANCEL UPDATE BUILDING

4. Add rooms.

a) From the drop-down list, select **Resources**, and then click +.

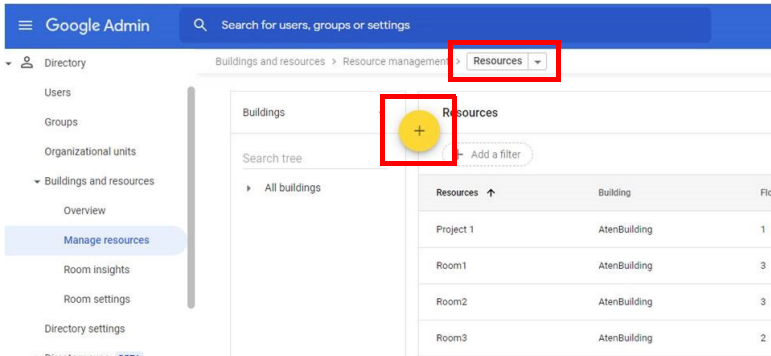

b) In the pop-up dialog box, select **Meeting space** for Category, the correct floor for the floor and resource, and fill in other information as needed.

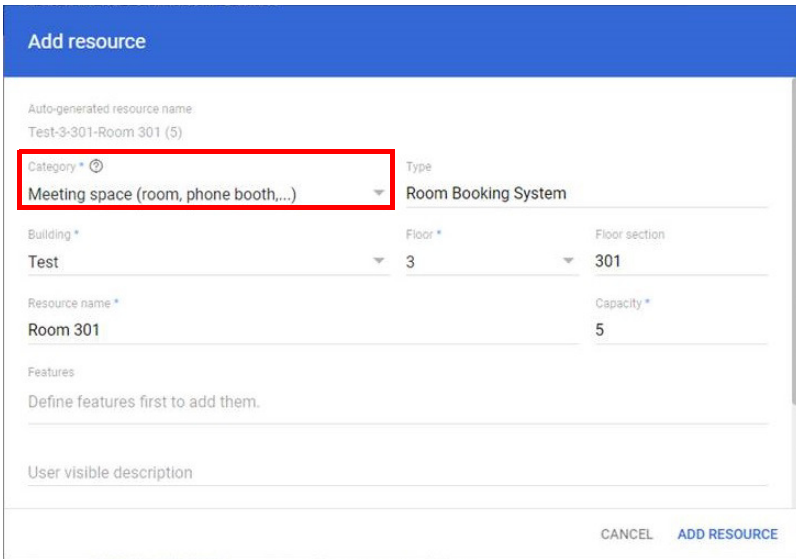

c) Click **Add Resource**. The room added to the Resources list.

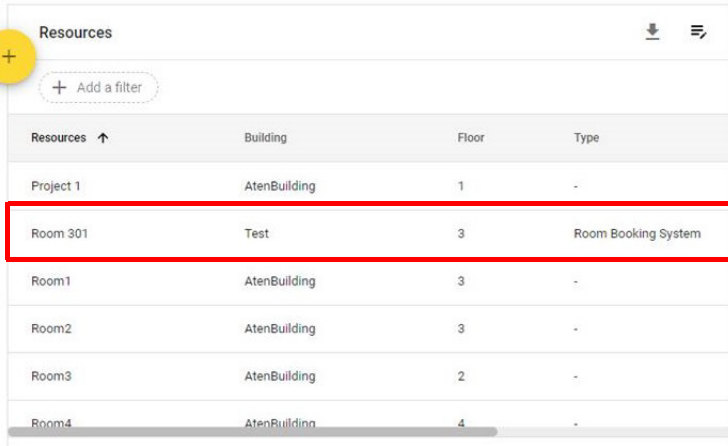

Resources ↑	Building	Floor	Type
Project 1	AtenBuilding	1	-
Room 301	Test	3	Room Booking System
Room1	AtenBuilding	3	-
Room2	AtenBuilding	3	-
Room3	AtenBuilding	2	-
Room4	AtenBuilding	4	-

5. Save the resource email of each added meeting space.
 - a) Go to the Resources list and click an added meeting space.
 - b) Copy and paste the resource email to a notepad to be used in RBS Configurator.

Enabling Google Calendar and Admin API

1. Sign in to Google Cloud console using administrator credentials.
2. Create a new project.
 - a) If you have pre-existing projects, click the **Select from** drop-down list, select an organization and click **NEW PROJECT**.



- b) If no project has not been created, go to **Organization Policies**, and then click **Add Project**.

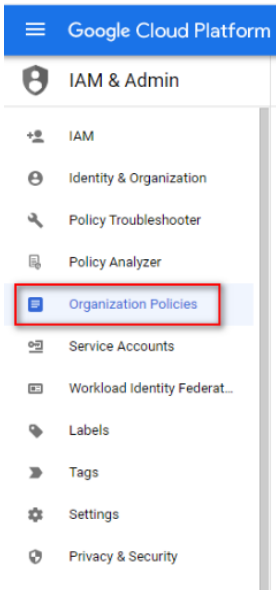

c) Configure the project details.

Project name *
CalendarTestv2 ?

Project ID: **utopian-bonito-301402**. After the project ID is set, it cannot be changed.
[EDIT](#)

mechanism *
gtest.aten.com.tw ▼ ?

Please select an organization to link to the project. Remind you that once the organization is selected, it cannot be changed.

position *
 gtest.aten.com.tw [BROWSE](#)

Parent organization or folder

[SET UP](#) [CANCEL](#)

d) Copy and paste the project name to a notepad for later use in the RBS Configurator.

3. Add the required APIs.

a) Select an organization and a project.

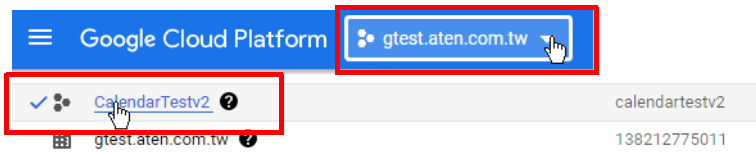

b) Go to **APIs and services > ENABLE APIs AND SERVICES**.

c) In the API Library window, search for and enable **Google Calendar API**.

d) In the API Library window, search for and enable **Admin SDK API**.

Creating a Service Account

1. On Google Cloud console, create a service account.
 - a) From the IAM and management list, go to **Service Accounts** > + **CREATE SERVICE ACCOUNT**.
 - b) Configure the service account. For role, select **Owner**. For example:

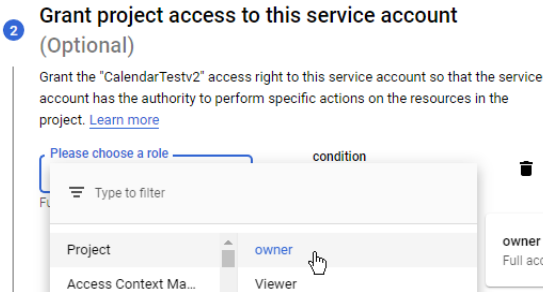
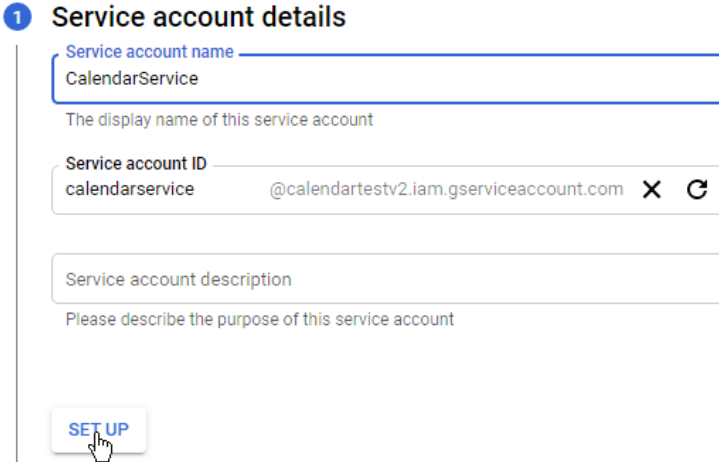

2. Generate a certificate key for the service account.
 - a) From the service accounts list, click the settings **⋮** button of the newly created service account, and click **Manage keys**.
 - b) From the Add Key drop-down list, select **Create new key**.
 - c) In the pop-up screen, select **JSON** as the key format, and click **CREATE**. The key is created and automatically downloaded to the computer.

- d) Know where the key is saved in the computer, you will need to upload the key to RBS Configurator later.

Authorizing Access from Third-party Applications

1. Set up Google Workspace Marketplace OAuth client.
 - a) Open the console left side menu and go to **APIs & Services > OAuth consent screen**.
 - b) For user type, select **Internal** and click **CREATE**.
 - c) Configure the OAuth consent.

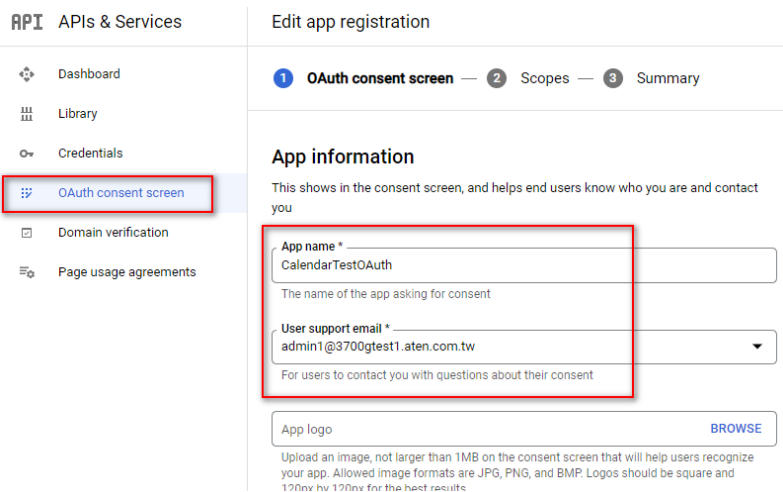

API APIs & Services

Dashboard

Library

Credentials

OAuth consent screen

Domain verification

Page usage agreements

Edit app registration

1 OAuth consent screen — 2 Scopes — 3 Summary

App information

This shows in the consent screen, and helps end users know who you are and contact you

App name *
CalendarTestOAuth
The name of the app asking for consent

User support email *
admin1@3700gtest1.aten.com.tw
For users to contact you with questions about their consent

App logo **BROWSE**

Upload an image, not larger than 1MB on the consent screen that will help users recognize your app. Allowed image formats are JPG, PNG, and BMP. Logos should be square and 120px by 120px for the best results

- d) From the service accounts list, click **View client ID**.
- e) Copy the client ID.

Client ID	117149984845206498199
Service account	CalendarService calendarservice@calendartestv2.iam.gserviceaccount.com
Creation date	January 12, 2021

2. Enable third-party application access.
 - a) Sign in to Google Admin console via admin.google.com
 - b) Go to **Security > Access and Data Control > API Controls > MANAGE ACCESS TO THIRD-PARTY APPLICATIONS**.

- c) Click **Add app** and then select **OAuth app**.
- d) Search for the client ID of the service account which you have obtained when setting up the service account. For example:

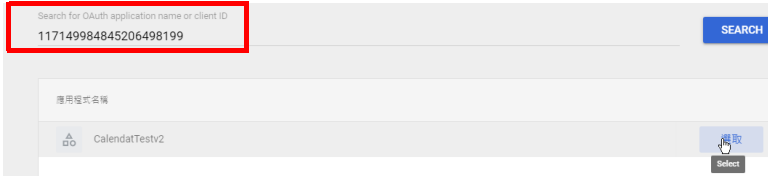

- e) Select **Trust** from the pop-up dialog.
3. Enable domain-wide delegation.
 - a) Go to **Security > Access and Data Control > API Controls > MANAGE DOMAIN-WIDE DELEGATION SETTINGS**.
 - b) For API client, click **Add New**.
 - c) In the pop-up screen, configure the following fields.
 - ◆ Client ID: paste the ID you copied in step 8.
 - ◆ Scope: fill in the following URLs separated by half-spaced commas
 - <https://www.googleapis.com/auth/calendar.events>
 - <https://www.googleapis.com/auth/calendar>
 - <https://www.googleapis.com/auth/admin.directory.user>
 - <https://www.googleapis.com/auth/admin.directory.group>
 - <https://www.googleapis.com/auth/admin.directory.resource.calendar>

Setting Up Google Workspace in ATEN RBS Configurator

1. Configure the RBS project via RBS Configurator.
 - a) In RBS Configurator, go to **Calendar Settings > Calendar > Google Workspace**.
 - b) Configure the following fields.
 - ◆ **Domain:** type the domain of your admin account.
 - ◆ **Admin Account:** type the admin account (email address) of Google Workspace.
 - ◆ **Project Name:** type the project name you saved from the previous step.
 - ◆ **Service Account:** type the project name you saved from the previous step.

- ◆ **Room Grouping:** enable this function to refine the list of available rooms (shows up by tapping Suggest Room on RBS panels) by only showing rooms in the same location.
 - **Disable:** This is the default setting.
 - **Display based on calendar server's settings:** displays available rooms that are in the same building and groups these rooms by floor.
 - **Display based on Unizon deployment tree's settings:** displays available rooms within the third last level and groups these rooms by the locations from the second last level.

For example, the image below illustrates a Unizon deployment tree, the last level being the rooms, the second last are floors, and the third last are the cities. When operating an RBS panel in Taiwan HQ to search for available rooms (using the Suggest Room function), all the available rooms in Taiwan HQ (third last level) will be listed by floor (second last level), and a drop-down list of floors will be available for users to switch.

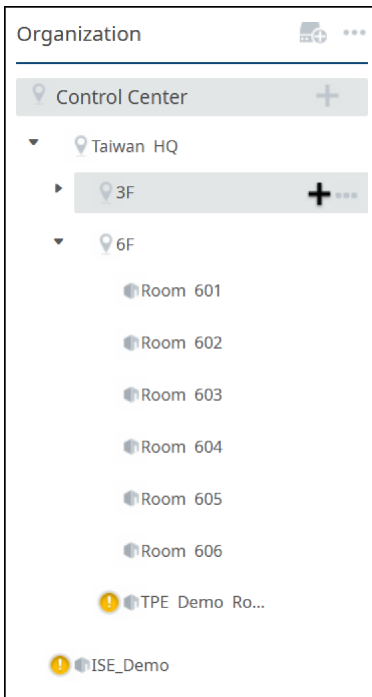

- ◆ **Certification File:** upload the certification file you generated for the service account.
2. Upload the project file to RBS panels to apply the setup.
For details, see *Uploading Profiles to infoPlayer/RBS Panels*, page 169.

DingTalk

The DingTalk is now supported on our ATEN RBS Configurator's calendar servers. For more information on how to configure the ATEN RBS Configurator to work with DingTalk, please contact your ATEN dealers.

DingTalk

App Key

App Secret

User ID

Room Grouping

 ▼

Panel Message

The *Panel Message* settings allow users to define the disconnection message to be displayed on the RBS Panels managed when they are not connected to the calendar server, as well as the contact info to be displayed on the RBS Panels' settings page.

To access the Panel Message settings, select **Calendar Settings > Panel Message** on your RBS Configurator.

Disconnection Message

Define the title and content of the disconnection message, as exemplified below.

The screenshot shows the RBS Configurator interface with three tabs: 'Edit Profile', 'Calendar Settings', and 'Panel Management'. The 'Calendar Settings' tab is active. On the left, a sidebar lists various calendar services: 'Microsoft 365', 'Google Workspace', 'Exchange', and 'Room Booking System'. Under 'Room Booking System', the 'Panel Message' option is highlighted. The main content area is titled 'Disconnection Message' and includes a description: 'Type a warning message to be displayed when the panel disconnects with the calendar server.' There are two sections: 'Disconnection Message' and 'Support Contact'. Each section has a 'Title' and 'Content' field. The 'Disconnection Message' fields contain the text: 'Not connected to the calendar system.' and 'Please contact the administrator for assistance.' The 'Support Contact' fields contain the text: 'Please contact the administrator for assistance.'

Once applied, the message will be displayed on the RBS Panels when they are not connected to the calendar server.

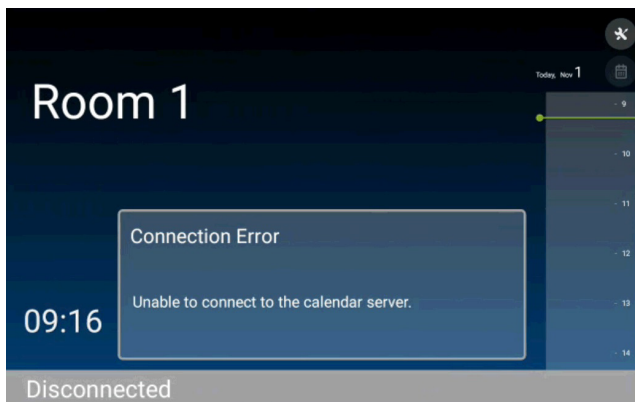

Support Contact

Define the contact info, for support or assistance, to be displayed on the RBS Panels' settings page, as exemplified below.

Support Contact

Add a support contact for the system administrator to be shown on the support center page.

Content

Please contact the administrator (#8888)

Once applied, the contact info is displayed on the RBS Panels' settings page.

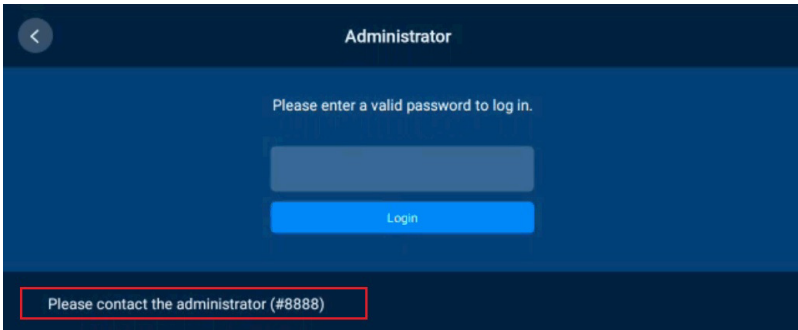

Chapter 5

infoPlayer and RBS Panel Operation

This chapter guides you through the operations that can be done on ATEN RBS Panels and an infoPlayer-connected display, including booking or checking into rooms.

Note:

- ◆ Before operating any of your infoPlayer displays or RBS Panels, make sure the necessary configurations and profiles have been uploaded and applied to them.
 - ◆ In highly humid environment, it is advised that you keep the touch panel powered on and in operation to prevent fogging inside the touch panel.
-

Operating RBS Panels

Meeting Room Panel Main Page

The components of the RBS Panel's main page are described below:

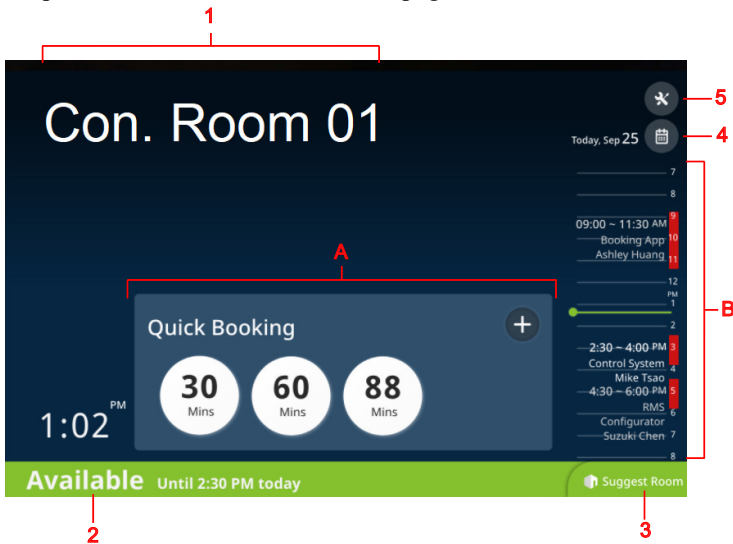

Note: To customize the display style of your RBS Panels, or add a brand / logo or background image via RBS Configurator, see *GUI Design*, page 52.

No.	Item	Description
A	Quick Booking / Check-in	<p>Provides varying functions based on the current status of the conference room: <i>Available</i>, <i>Reserved</i>, or <i>Occupied</i>.</p> <hr/> <p>Available</p> <ul style="list-style-type: none"> ◆ Quick Booking: Lets users start or schedule a meeting using the conference room through one of the following options: <ul style="list-style-type: none"> ◆ 30 / 60 / 90 / X: Immediately starts a meeting for 30 / 60 / 90 / X minutes, where X is the number of minutes the room is available for until the next scheduled meeting or the end of the working hour. <p>Note: Since the maximum duration allowed for each booking is 120 minutes, X can only be 120 minutes at most.</p> ◆  : Tap to schedule a meeting. See <i>Booking a Room</i>, page 137, for details. ◆ Quick Booking with Unizon's Timetable: Allows users to quick book currently available conference rooms through the Room Booking System. Any bookings or changes made in the Room Booking System are reflected in Unizon's Timetable, enabling real-time, bi-directional event synchronization. For more information, please refer to the <i>Unizon user manual</i>.
	Reserved	<ul style="list-style-type: none"> ◆ Check In: During a meeting's scheduled time, lets users to check in to the room and start the meeting. ◆ Release: During a meeting's scheduled time, lets users to cancel it and release the room for others to use. ◆ Meeting information: Tap the information icon at the top-right corner to see meeting details or remove the meeting record from the system by tapping the Delete Meeting button. This button only appears if the meeting was booked from the panel.

No.	Item	Description
	Occupied	<ul style="list-style-type: none"> ◆ Check Out: During an ongoing meeting, lets users to check out of the room and end the meeting. ◆ Extend: During an ongoing meeting, lets users to extend the meeting time if the conference room is available for further use. ◆ Meeting information: Tap the information icon at the top-right corner to see meeting details or remove the meeting record from the system by tapping the Delete Meeting button. This button only appears if the meeting was booked from the panel.
B	Today's Scheduled Meetings	Displays all meetings the conference room has scheduled during the day.
1	Room Display Name	Displays the name of the conference room.
2	Room Status	<p>Displays the status of the conference room.</p> <ul style="list-style-type: none"> ◆ Available: Indicates the room is available for use. ◆ Reserved: Indicates the room is reserved for a meeting, but not yet checked into. ◆ Occupied: Indicates the room is currently hosting an ongoing meeting.
3	Suggest Room	Suggests conference rooms currently available for hosting a meeting. See <i>Using the Suggest Room Function Without Unizon</i> , page 139, for details.
4	Other Dates	Displays all meetings scheduled within the Room Booking System, see <i>Viewing Meeting Schedule</i> , page 135.
5	Settings	<ul style="list-style-type: none"> ◆ Accesses support center. Please note that the support center is available only when used with Unizon. ◆ Accesses administrator settings, see <i>Administrator Settings</i>, page 152.

Classroom Panel Main Page

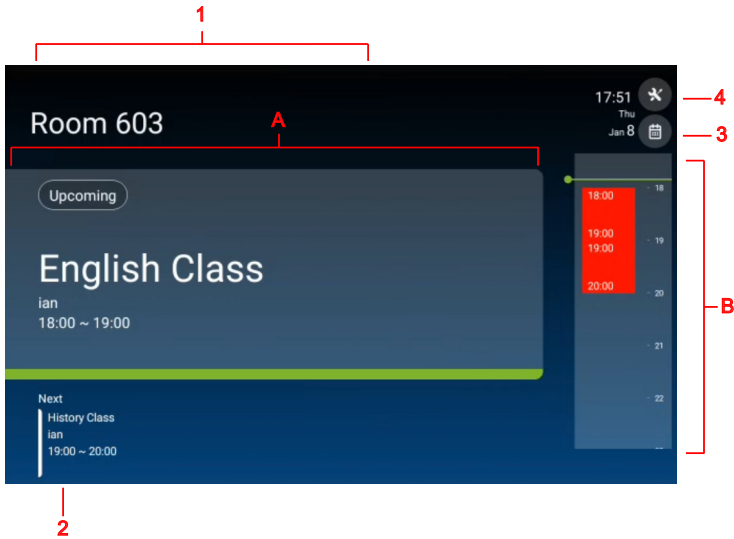

Note: To customize the display style of your RBS Panels, or add a brand / logo or background image via RBS Configurator, see *GUI Design*, page 52.

No.	Item	Description
A	Event Information	Displays current or upcoming event information. Sign On / Use ID Pin: Tap to sign on for the attendance record. To enable this feature, configure the Sign-On Period under Booking Setting (page 56) for classroom layout type.
B	Today's Scheduled Events	Displays all events the classroom has scheduled during the day.
1	Room Display Name	Displays the name of the event.
2	Next Upcoming Event Information	Displays the next upcoming event's information.
3	Other Dates	Displays all events scheduled within the Room Booking System, see <i>Viewing Meeting Schedule</i> , page 135.
4	Settings	<ul style="list-style-type: none"> ◆ Accesses support center. Please note that the support center is available only when used with Unizon. ◆ Accesses administrator settings, see <i>Administrator Settings</i>, page 152.

Viewing Meeting Schedule

Today's Scheduled Meetings

To view meetings scheduled throughout the day, simply tap and drag on the ATEN RBS Panel's *Daily Schedule Area*.

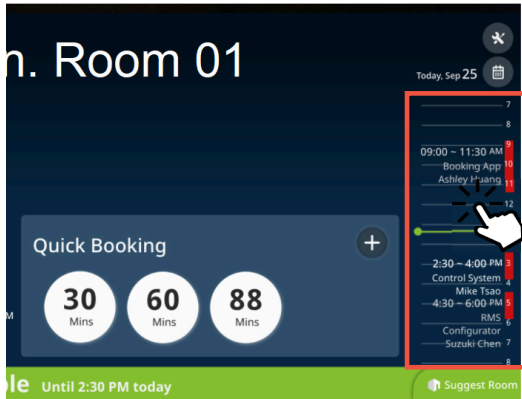

Meetings Scheduled on Other Dates / for Other Rooms

To view meeting schedules for other dates or for other conference rooms, tap the calendar icon . The following page appears.

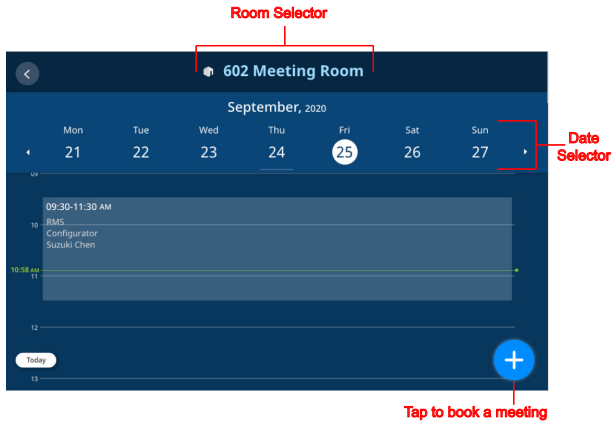



Select the desired conference room and date to view the corresponding meeting schedule.

To book a room and schedule a meeting, tap  and see *Booking a Room*, page 137 for details.

Booking a Room

Using the Calendar

To book a room and schedule a meeting, tap  from an RBS panel's main page, and then tap  or  from the pop-up page. The following page appears.

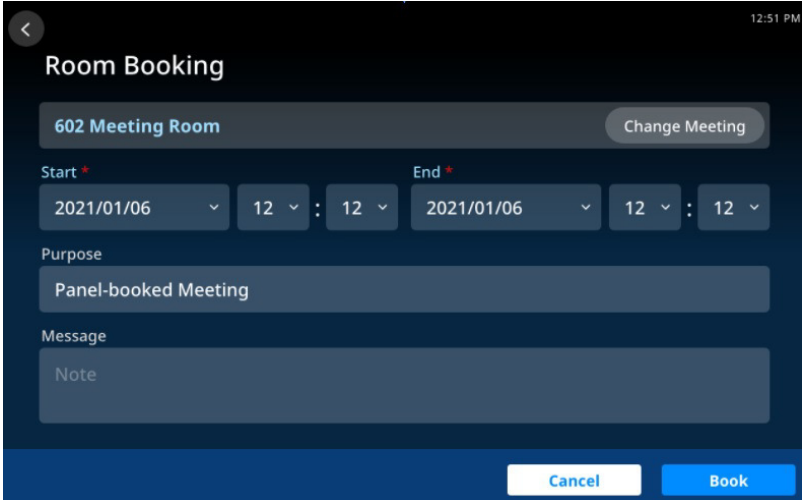

The screenshot shows a mobile application interface for booking a room. At the top left is a back arrow, and at the top right is the time '12:51 PM'. The main title is 'Room Booking'. Below the title is a text input field containing '602 Meeting Room' and a 'Change Meeting' button. Underneath are two rows of time selection controls. The first row is labeled 'Start *' and the second 'End *'. Each row has three dropdown menus: a date dropdown (both set to '2021/01/06'), a time dropdown (both set to '12'), and a separator ':'. Below the time controls is a 'Purpose' label followed by a text input field containing 'Panel-booked Meeting'. Below that is a 'Message' label followed by a larger text input field containing the placeholder text 'Note'. At the bottom right of the form are two buttons: 'Cancel' and 'Book'.

1. Select the desired conference room.
2. Specify the meeting's start and end times.
3. Fill in other desired fields.
4. Tap **Book** to finish.

Scan & PIN Function

To use scan card or PIN function to book a room, you have to enable Identity Checkup in the Device Configuration page, see *Identity Checkup*, page 166. This is only available and configured through ATEN Unizon. For more information, see *ATEN Unizon User Manual*.

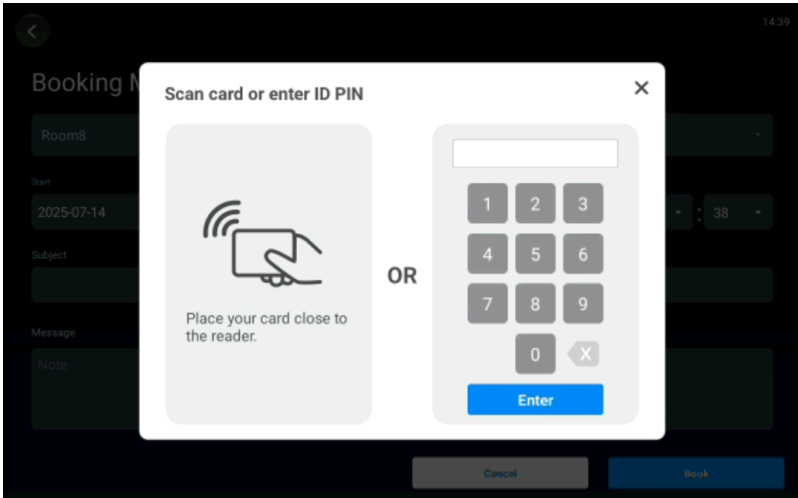

Splitting Room Name using Break Symbol

If the room name becomes too long, you can use the break symbol feature to split it for a flexible display. This feature is available from the Room Booking System, under **Device Management > Calendar Account**, see *Calendar Account*, page 165.

without break symbol

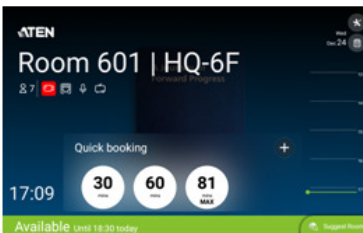

with break symbol

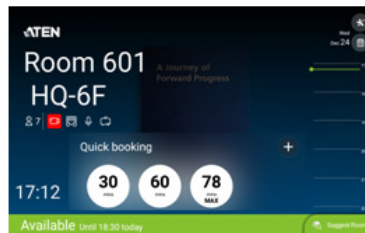

Using the Suggest Room Function Without Unizon

The *Suggest Room* function suggests conference rooms, currently available for use within the Room Booking System, to users for convenient meeting hosting.

1. From the main page of a RBS Panel, tap **Suggest Room**.

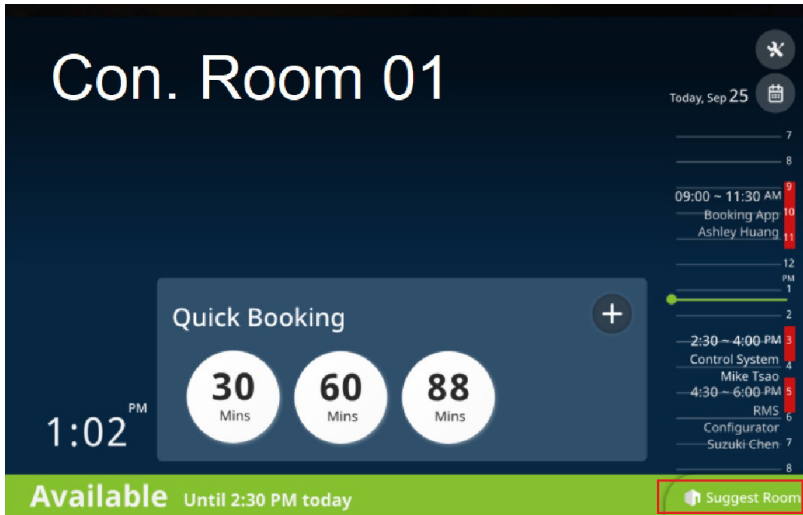

2. Select the desired meeting time.

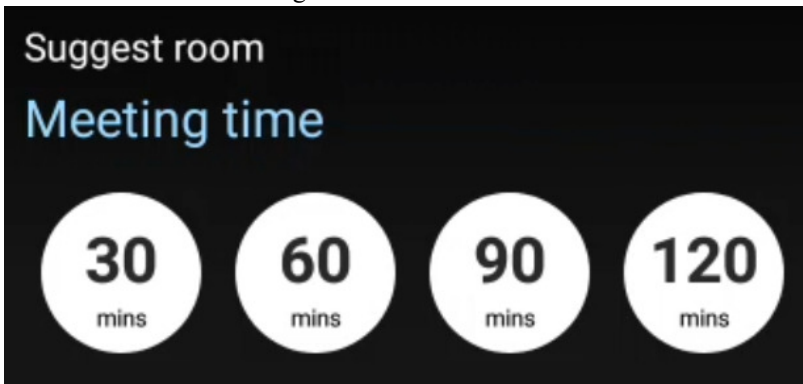

3. Based on your meeting time, the Room Booking System displays the conference rooms that are currently available for use, as exemplified below.

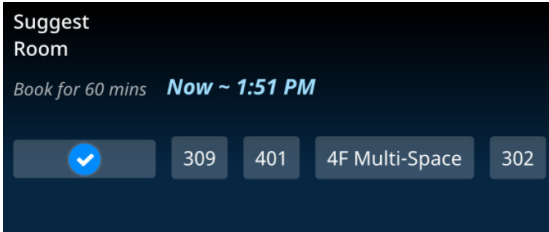

4. Select the desired room to finish. The conference room selected is now hosting a meeting for the time specified. You can now go to that conference and check in to start your meeting.

Using the Suggest Room Function With Unizon

The *Suggest Room* function suggests conference rooms, currently available for use within the Room Booking System, to users for convenient meeting hosting.

1. From the main page of a RBS Panel, tap **Suggest Room**.

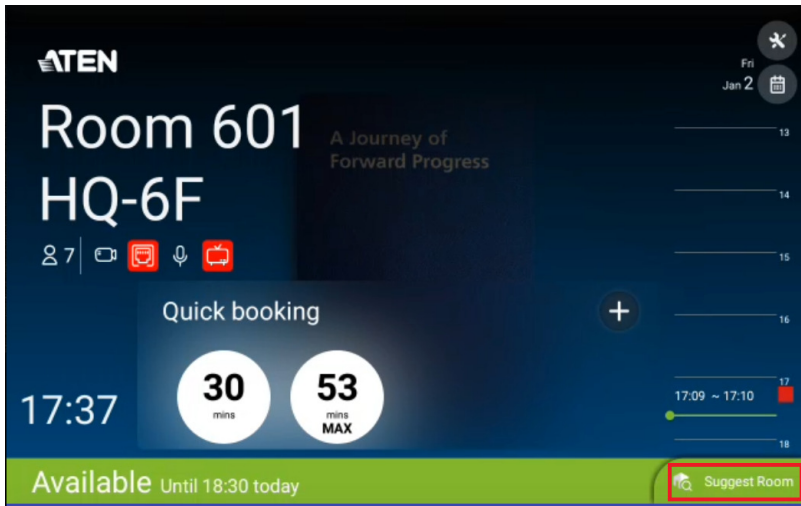

2. Select the desired meeting time.

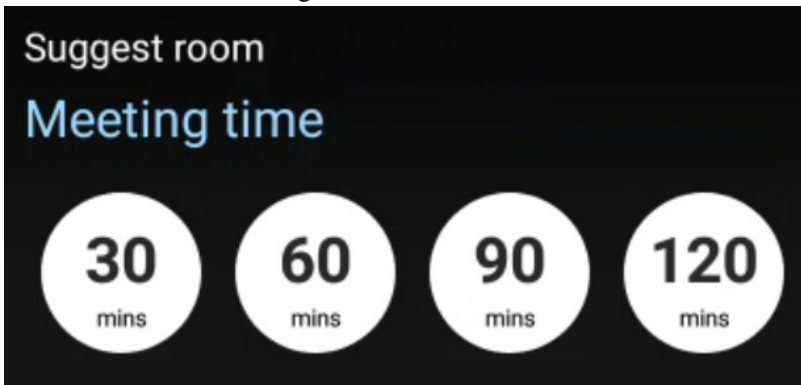

3. Based on your meeting time, the Room Booking System displays the conference rooms that are currently available for use, as exemplified below.

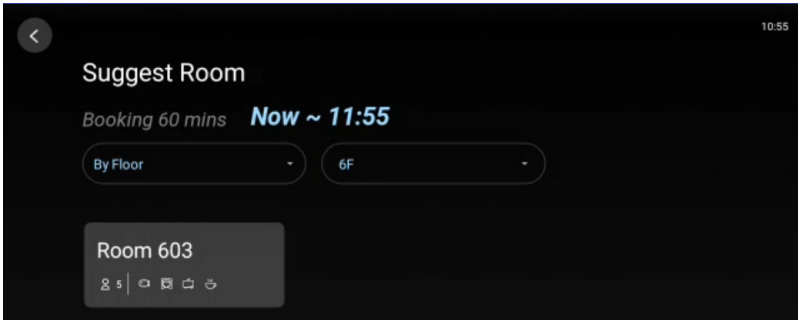

4. Or, you can use the drop-down menu to search available room via by floor, members, or device.

- ◆ By Floor

When **By Floor** is selected, tap the drop-down menu next to it to choose a floor for the available room. The By Floor filter is configurable through Unizon or the calendar server. For more information, please refer the to *Unizon user manual* or the *Calendar Server* pages listed below.

- ◆ Microsoft 365: page 78.
- ◆ Microsoft Exchange: page 89.
- ◆ Google Workspace: page 117.

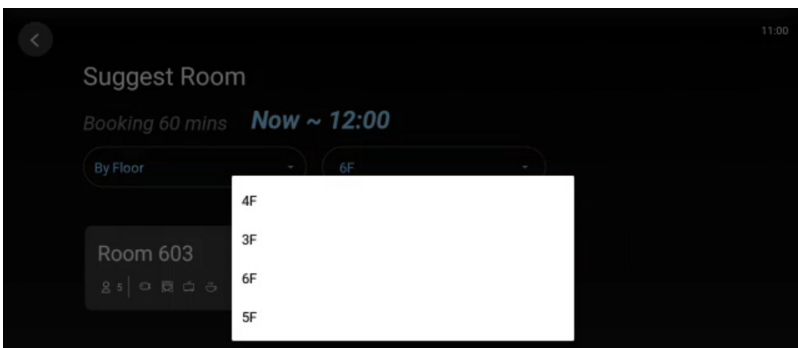

- ◆ By Members

When **By Members** is selected, tap the drop-down menu next to it to choose the member capacity for the available room. The By Members

filter is configurable only through Unizon. For more information, please refer the to *Unizon user manual*.

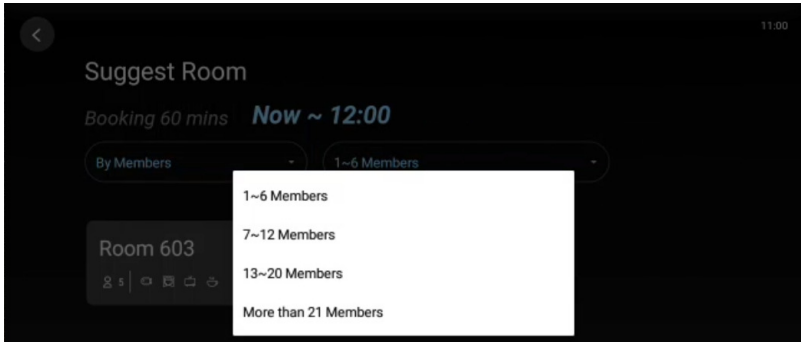

- ◆ By Device

When **By Device** is selected, tap the drop-down menu next to it to choose device / service supported for the available room. Click **Apply** when done. The By Device filter is configurable only through Unizon. For more information, please refer the to *Unizon user manual*.

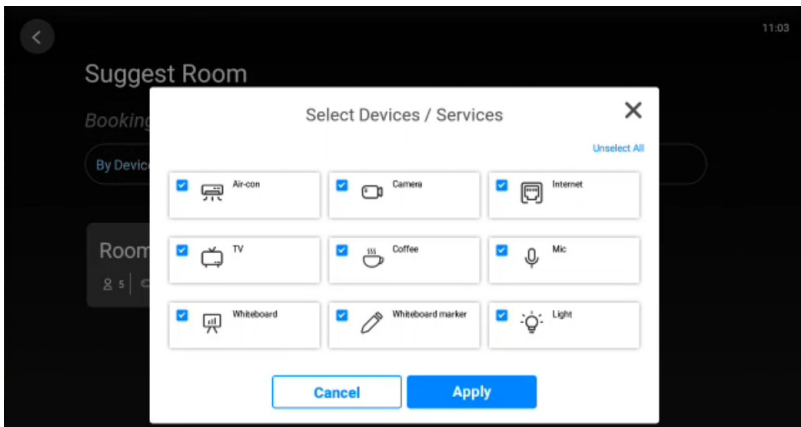

5. Select the desired room to finish. The conference room selected is now hosting a meeting for the time specified. You can now go to that conference and check in to start your meeting.

Using Sign-on for Attendance Record with Unizon

The *Sign-on* function allows users to set a time window for recording student attendance before and after an event starts. To configure the time window, see *Sign-On Period*, page 56. To download the record from Unizon, please refer to the *Unizon user manual*. The classroom template is used in the screenshot below. The sign-on function is available for both the meeting room and classroom templates.

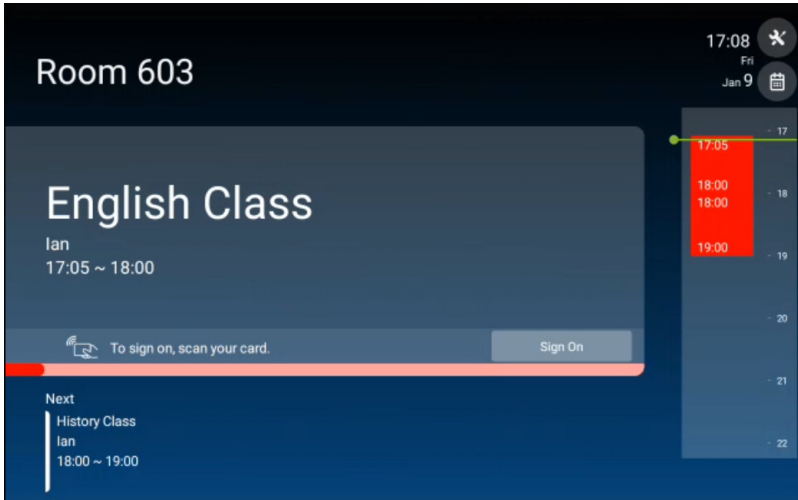

Canceling a Reservation

If a room has been booked from an RBS panel, you can cancel the reservation from the panel.

1. Tap the meeting from the list of scheduled meetings.

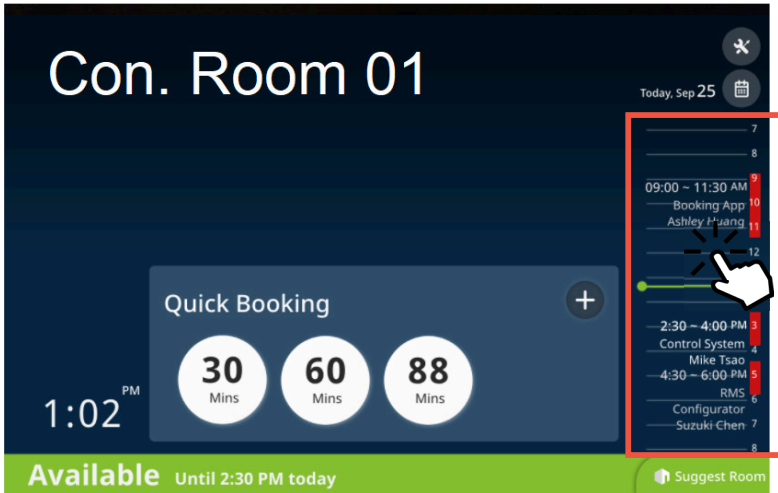

Or tap the information icon from the check-in panel:

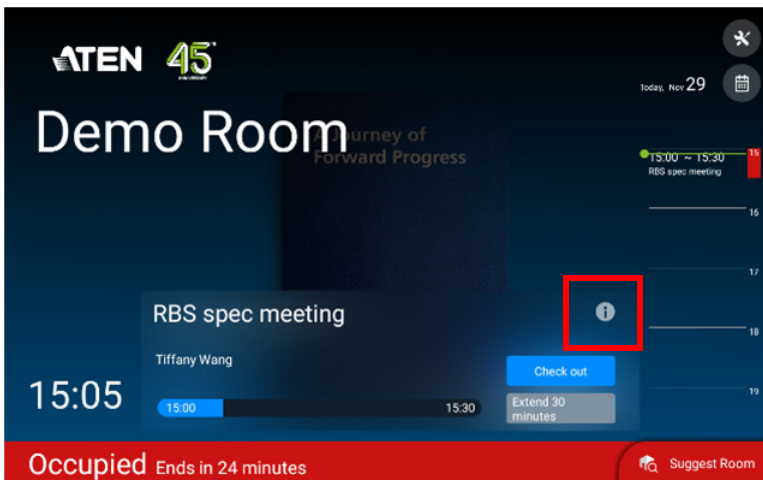

2. Tap the **Delete Meeting** icon and then tap **OK** to cancel the meeting. Please note, only meeting that is made on the panel can be deleted from the panel.

Submitting User Request

For example, if you need assistance with a malfunctioning camera, you can go to support center page and submit a camera user request. To access the support center page, follow the steps below.

1. Tap  from the RBS Panel's main page.

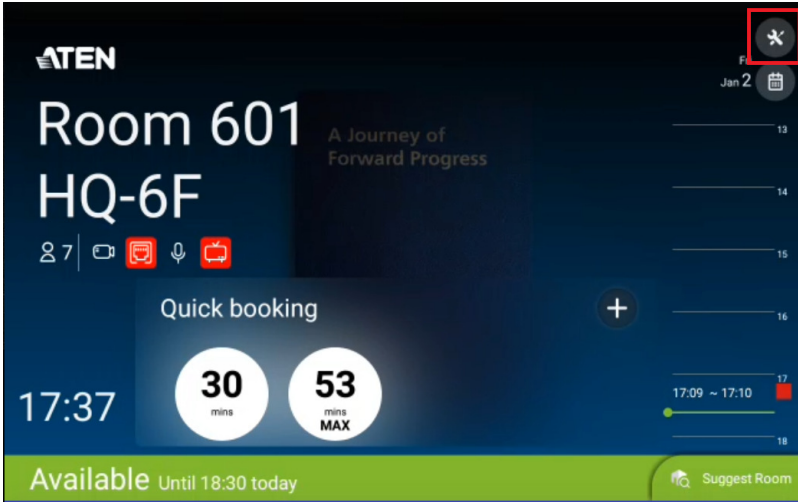

2. From the support center page, tap a device for user request.

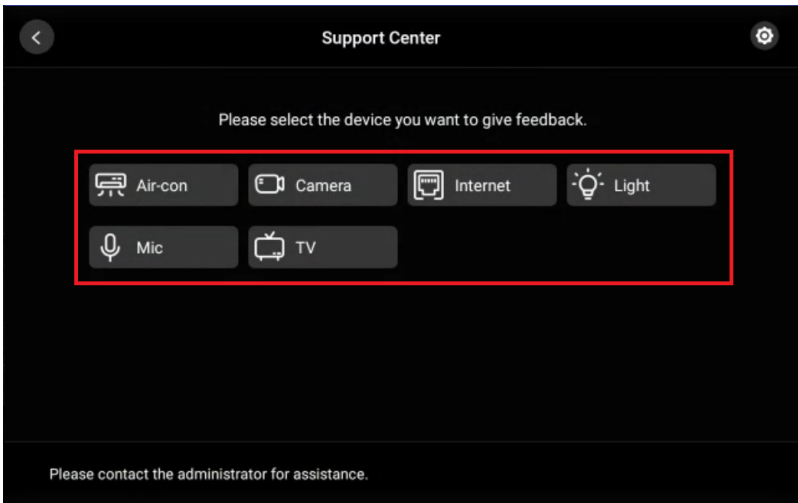

- For example, if you need assistance for camera, tap **Camera** and the pop-up message appears. You may tap **Confirm** to submit the request or the user request will be submitted once the count down is finished.

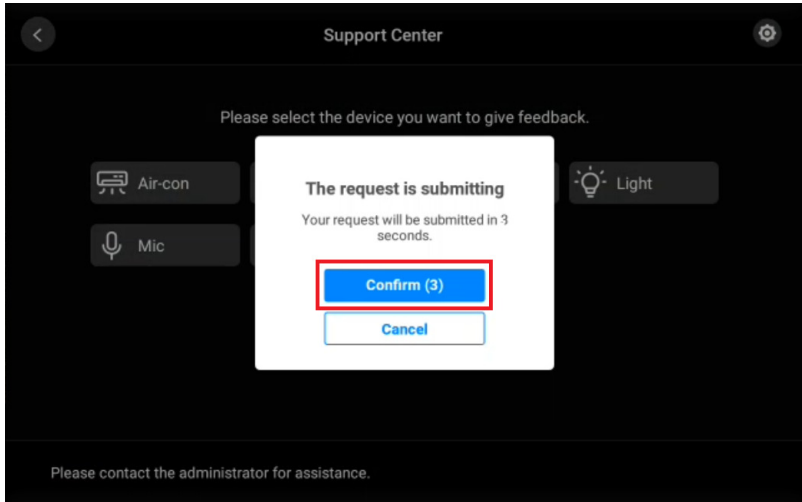

- The Camera icon is now greyed out on the support center page to indicate that the user request has been submitted.

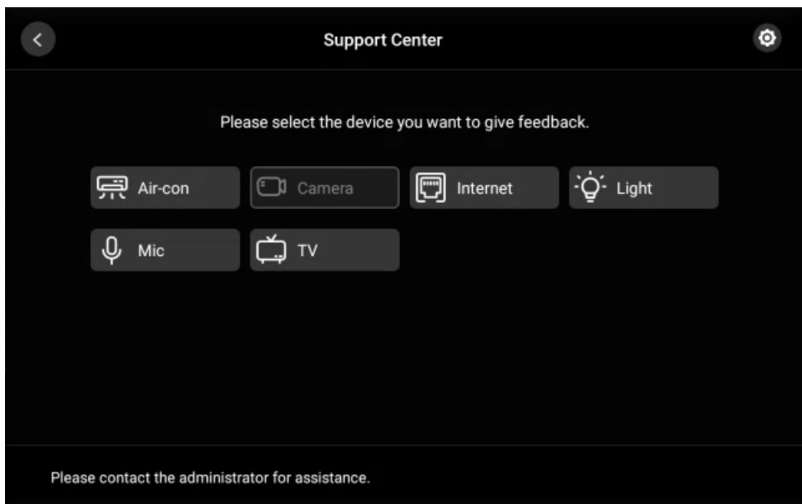

5. In the RBS Panel main page, a white camera icon on a red background appears to indicate that the user request has been submitted.

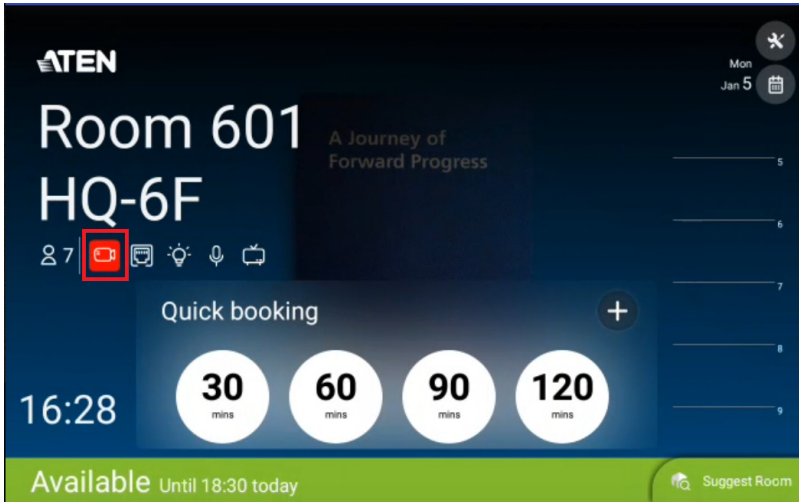

6. To close the user request, go to support center page, tap the user request you want close (icons that are greyed out).

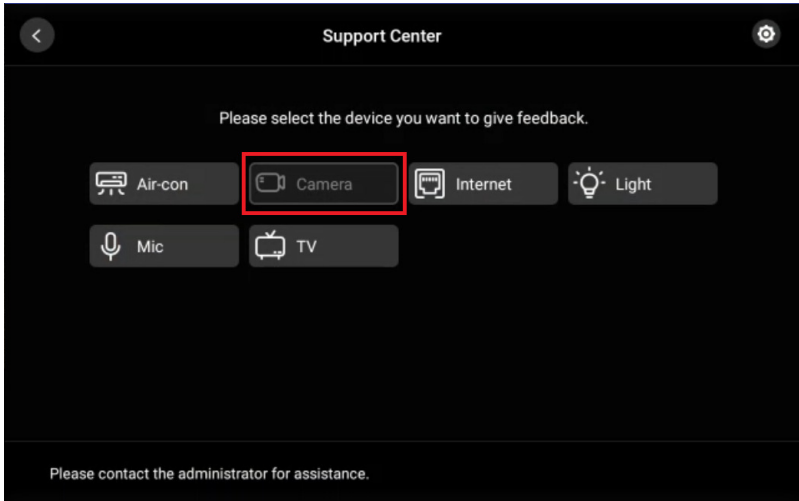

7. A pop-up message appears. Tap **Yes** to close user request.

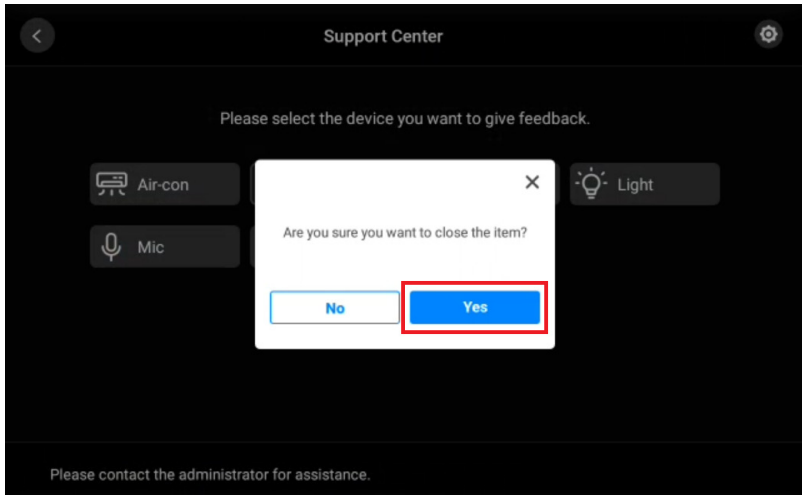

Quick Submitting / Closing User Request

Quick user request can be submitted or closed from the RBS Panel main page without accessing the support center, User request icons can be enabled on the RBS Panel main page. See the *ATEN Unizon User Manual* for configuration details.

To submit a user request, follow the steps below.

1. Tap a user request icon from the RBS Panel's main page.

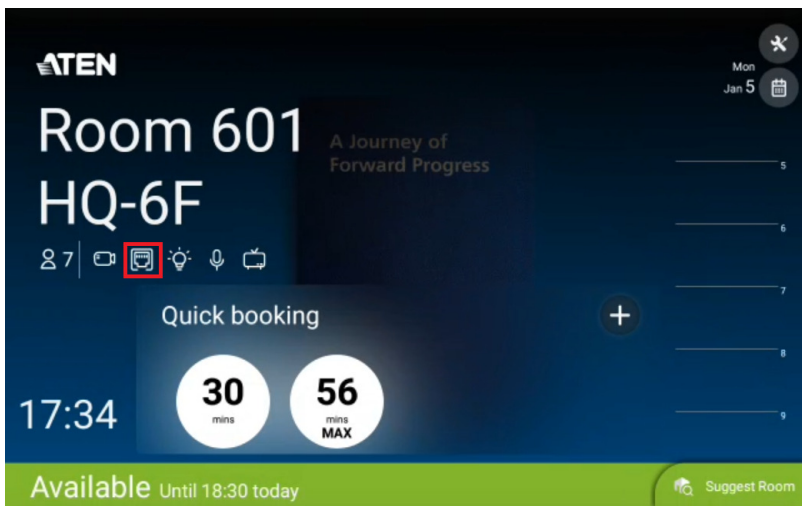

2. A pop-up message appears, tap **Confirm** to submit the user request.

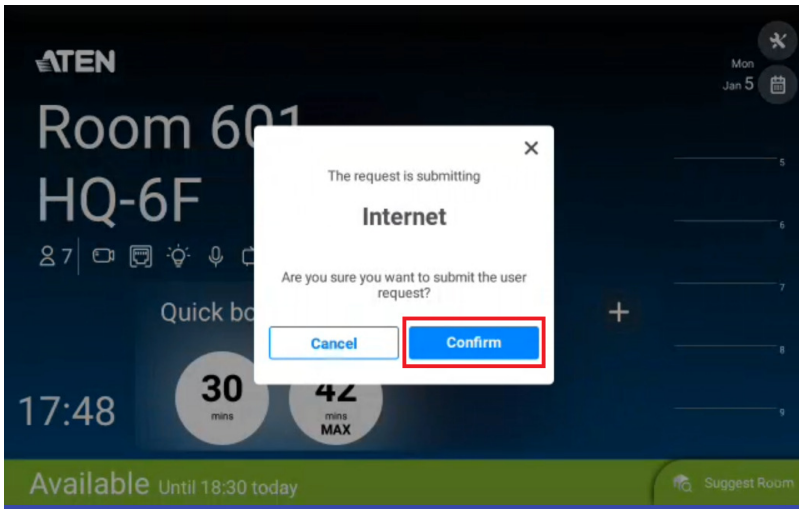

3. In the RBS Panel main page, a white Internet icon on a red background appears to indicate that the user request has been submitted.

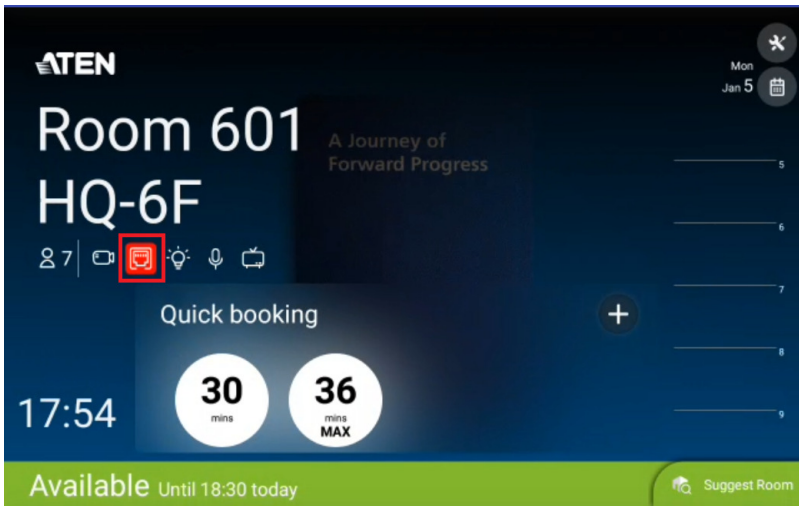

4. To close the user request, tap the user request you want close (white icons on a red background).

5. A pop-up message appears. Tap **Yes** to close user request.

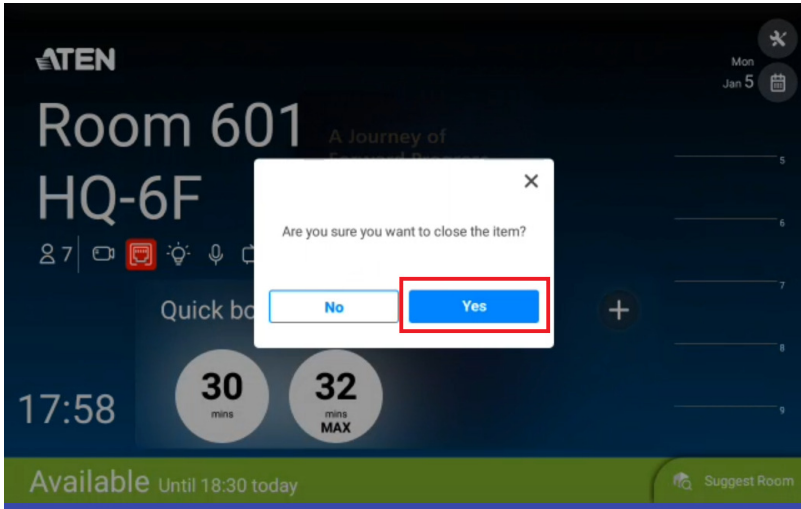

Administrator Settings

The *Settings* page of RBS Panels contains its network and password settings. To access, tap  from the RBS Panel's main page and enter the required password.

Enabling / Disabling Access to Basic Panel Settings

To prevent alteration of basic panel settings, such as volume, display settings, network configuration, and password setup, you can disable the Brightness, Volume, and Function buttons, as illustrated below.

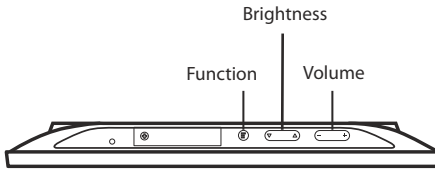

RBS Panel Top View

To disable the Function, Brightness, and Volume buttons, follow the steps below.

1. From the RBS panel, tap .
2. Log in with valid credentials. This screen appears.

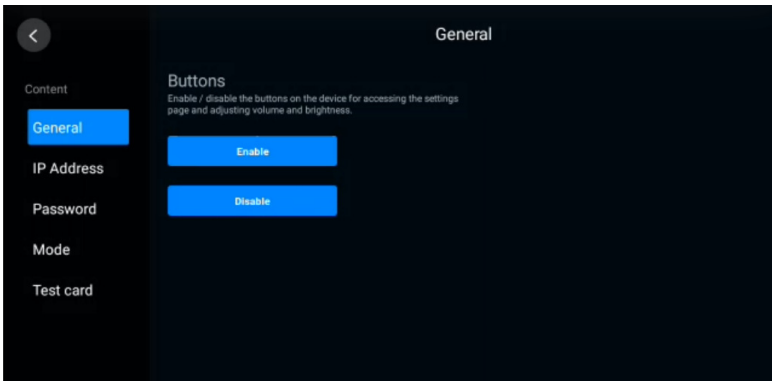

3. Tap **Disable**. A confirmation message appears.
4. Tap **Yes** to confirm the setting and restart the device.

Configuring Network Settings

To configure the IP address of an RBS panel to a dynamic or fixed IP address, follow the steps below to access the settings.

1. From the main page of the RBS panel, tap .
2. Log in with valid credentials. This settings page appears.
3. Tap **IP Address** from the left sidebar. The Ethernet Settings page appears.

The screenshot displays the 'Ethernet Settings' page. On the left is a dark sidebar with a back arrow at the top and menu items: 'Content', 'General', 'IP Address' (highlighted in blue), 'Password', 'Mode', and 'Test card'. The main content area has a title 'Ethernet Settings' and a back arrow. Below the title are several settings:

- IP address mode:** A dropdown menu currently set to 'Use Static IP Address'.
- IP Address:** A text input field containing '10.3.66.20'.
- Subnet Mask:** A text input field containing '255.255.255.0'.
- Default Gateway:** A text input field containing '10.3.66.254'.
- DNS 1:** A text input field containing '10.0.1.6'.
- DNS 2:** A text input field containing '10.0.1.7'.

At the bottom of the page are two buttons: a white 'Cancel' button and a blue 'Save' button.

4. Configure the settings as required.
5. Tap **Save** to applied the configuration.

Setting the Password

To change the panel password:

1. From the RSB panel, tap .
2. Log in with valid credentials. This settings page appears.
3. Tap **Password** to access the password settings.

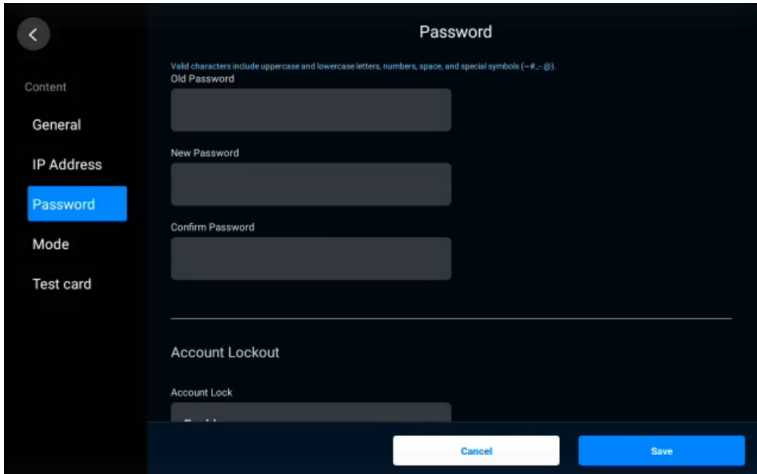

Account Lockout

To prevent login attempt to the RBS panel from unauthorized user, an account lockout function can be configured. You can enable this function, set login attempts and timeout duration.

Obtaining Card Numbers

To find out a card number, as detected by ATEN Access Inspector or to test if a pre-existing card is supported by ATEN Access Inspector, use the Test Card function.

1. Make sure you have installed at least one RBS panel with an Access Inspector. For details, see *Installing an Access Inspector to an RBS Panel*, page 14.
2. On the RBS panel, tap  and enter the administrator password to log in.
3. Tap **Test Card** from the left panel. This screen appears.

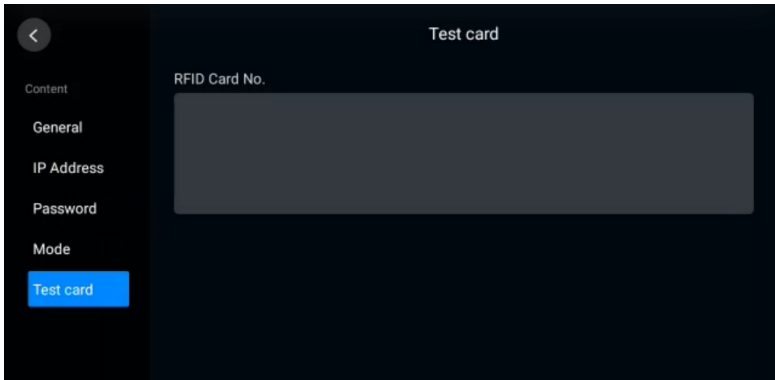

4. Scan an access card on the Access Inspector. If a series of numbers appears, the card is supported by ATEN Access Inspector.

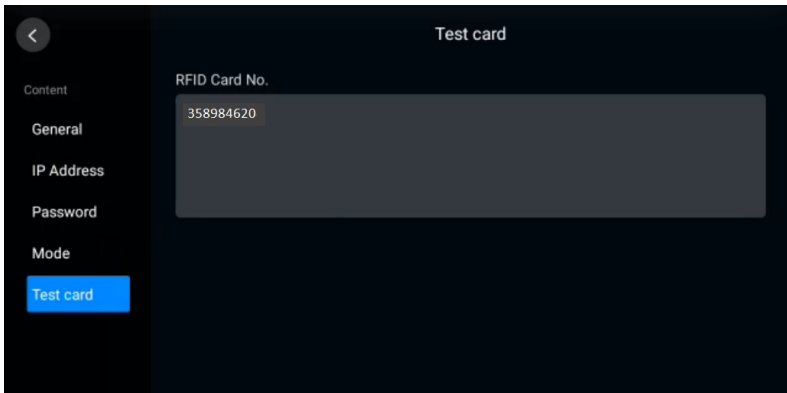

Enabling Demo Mode

Demo mode is an offline mode in which you can demo and try out different settings on the RBS panel without having the configurations sent and saved to the connected calendar server. Use one of the following methods to enable demo mode.

- ◆ From the panel's settings page (), enter the password and then tap **Demo Mode > Enable Demo Mode**.
- ◆ *Disconnect the RBS panel from the network*
 1. Power on the RBS panel and disconnect it from the network. This screen appears.

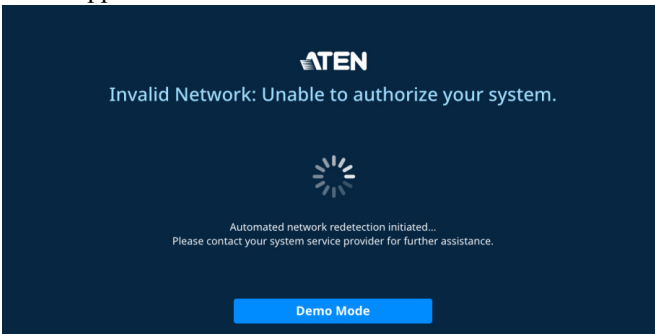

2. Tap the **Demo Mode** button, and then tap **Yes** to enter demo mode. When enabled, a red **Demo Mode** button appears on the top, as illustrated below.

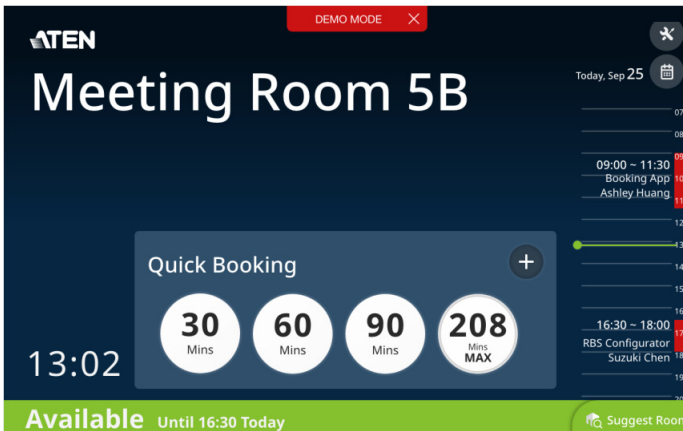

Disabling Demo Mode

Use one of the following methods to disable demo mode.

- ◆ From the panel's main page, tap the **Demo Mode** button on the top and tap **Yes** to confirm the action.
- ◆ From the panel's settings page () , enter the password and then tap **Mode > Exit Demo Mode**.

Operating an infoPlayer Display

Components Overview

Normal Mode

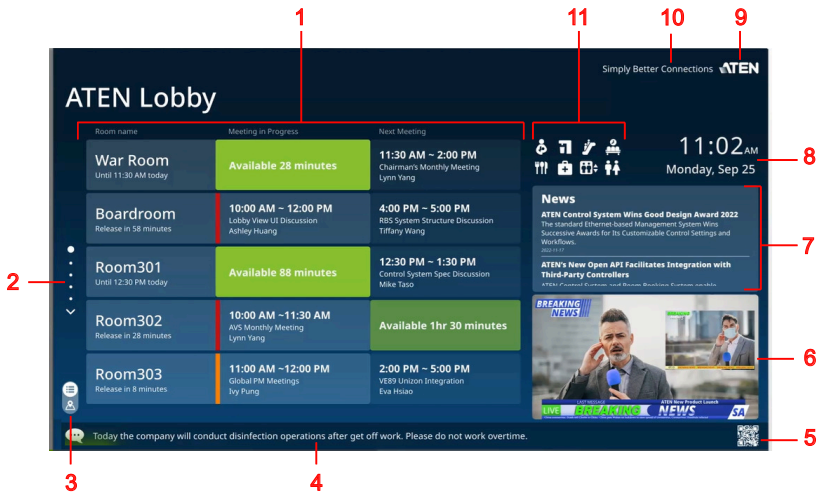

The infoPlayer display may contain the following components, depending on your configuration.

No.	Component	Function / Operation
1	Room status	<ul style="list-style-type: none"> Shows availability and status of each room, either in a list view or map view. Available rooms are indicated in green (default). Reserved and occupied rooms are indicated with a thin bar in orange and red, respectively (default).
2	Page bar	Indicates that there are multiple pages. Swipe on the screen to go to turn the page.
3	View mode switch	Tap to switch between list view and map view.
4	Announcement	Shows an announcement for the organization or visitors.
5	QR code	Scan the QR code to obtain more information.

No.	Component	Function / Operation
6	Video	Plays an embedded video.
7	News	Shows recent news. Optionally hide the news.
8	Date & Time	Indicates the current date and time.
9	Company logo	Shows the company logo.
10	Slogan	Shows the brand slogan.
11	Facilities	Indicates available facilities for the venue.

Spotlight Mode

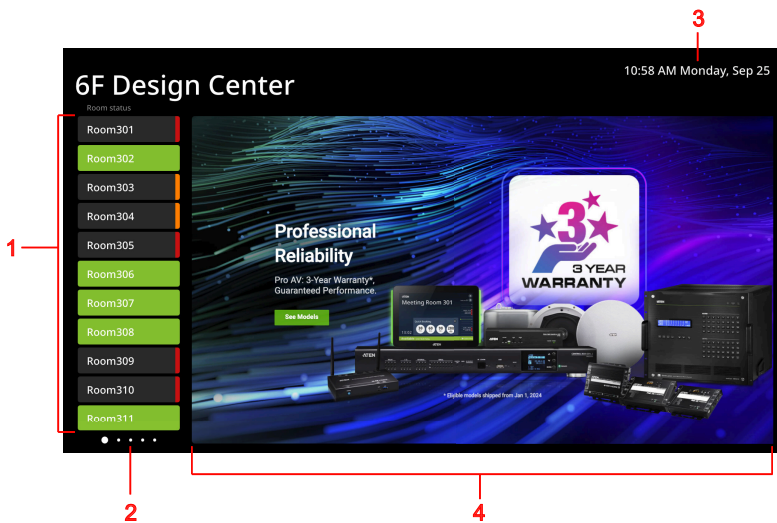

No.	Component	Function / Operation
1	Room status	<ul style="list-style-type: none"> Shows availability and status of each room, either in a list view or map view. Available rooms are indicated in green (default). Reserved and occupied rooms are indicated with a thin bar in orange and red, respectively (default).
2	Page bar	Indicates that there are multiple pages. Swipe on the screen to go to turn the page.
3	Date & Time	Indicates the current date and time.

No.	Component	Function / Operation
4	Spotlight Content	Plays an embedded video or shows recent news.

Reserving a Meeting Room from an infoPlayer Display

1. On the infoPlayer display, look for any available rooms with sufficient time for your needs.

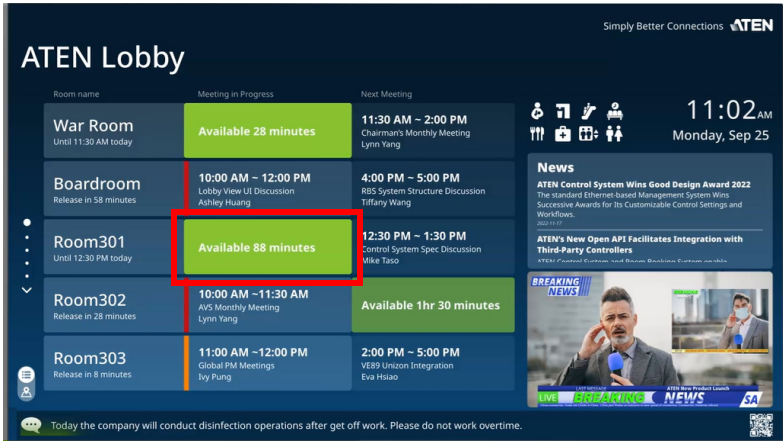

2. Tap on an available room, a quick booking box appears.

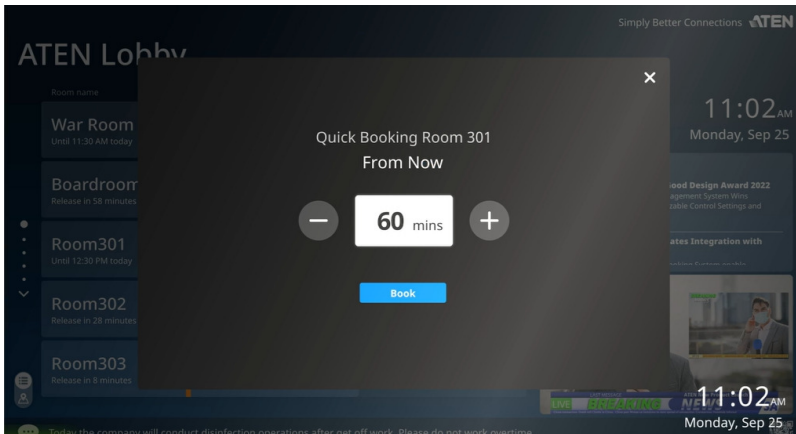

3. Tap on the display to adjust the duration, and then tap **Book**. The reservation is then applied and reflected on the infoPlayer display.

The screenshot shows the ATEN Lobby infoPlayer interface. At the top right, it says "Simply Better Connections ATEN" and the time is 11:02 AM on Monday, Sep 25. The interface is divided into three columns: "Room name", "Meeting in Progress", and "Next Meeting".

Room name	Meeting in Progress	Next Meeting
War Room Until 11:30 AM today	Available 28 minutes	11:30 AM ~ 2:00 PM Chairman's Monthly Meeting Lynn Yang
Boardroom Release in 58 minutes	10:00 AM ~ 12:00 PM Lobby View UI Discussion Ashley Huang	4:00 PM ~ 5:00 PM RBS System Structure Discussion Tiffany Wang
Room301 Until 12:30 PM today	11:02 AM ~ 12:02 PM Quick Booking Room301	12:30 PM ~ 1:30 PM Control System Spec Discussion Mike Taso
Room302 Release in 28 minutes	10:00 AM ~ 11:30 AM AVS Monthly Meeting Lynn Yang	Available 1hr 30 minutes
Room303 Release in 8 minutes	11:00 AM ~ 12:00 PM Global PM Meetings Jyy Pung	2:00 PM ~ 5:00 PM VE89 Unizon Integration Eva Hsiao

On the right side of the display, there is a "News" section with two articles: "ATEN Control System Wins Good Design Award 2022" and "ATEN's New Open API Facilitates Integration with Third-Party Controllers". Below the news is a "BREAKING NEWS!!" banner with a video player showing a man speaking into a microphone.

This Page Intentionally Left Blank

Chapter 6

Device Management

The **Device Configuration** tab, in ATEN RBS Configurator, allows you to configure the infoPlayer/RBS panel settings and upload these setting profiles to these managed devices.

Managing the infoPlayer and RBS Panels via RBS Configurator

Loading Devices to RBS Configurator

To start, follow the steps below to search to load the devices you want to manage.

1. In RBS Configurator, click the **Device Configuration** tab and select **infoPlayer** or **Room Panel** from the pop-up menu. This screen appears.

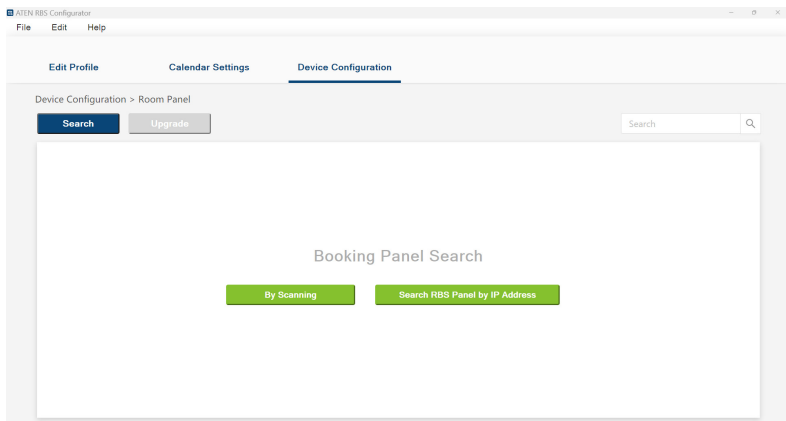

2. Use one of the following methods to search and load the target devices:
 - ♦ **Auto Scan:** Click the **By Scanning** button to automatically searches for all infoPlayer or RBS Panels within the same subnet.
 - ♦ **Search by IP address:** Click the **Search RBS Panel by IP Address / By IP Address** button to search for infoPlayer devices or RBS Panels within the LAN by entering an IP range or a specific IP address.

Devices are loaded into the RBS Configurator.

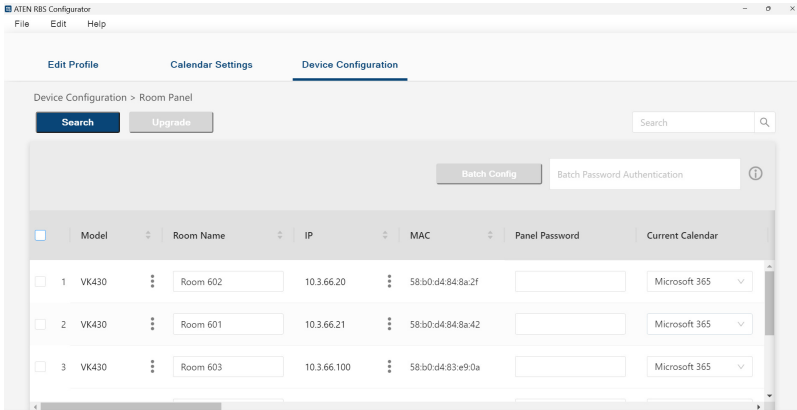

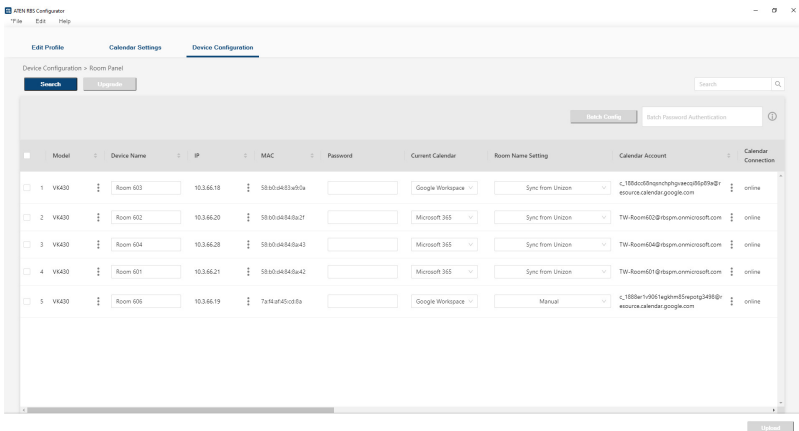

Device Configuration Options

After at least 1 infoPlayer or RBS Panel has been found by the RBS Configurator, its related information and configuration options are displayed. A list of RBS panels are used as an example below.



Item	Description
Model	Displays the model of the infoPlayer/RBS Panel. ♦ Click  to optionally reset the RBS panel to default settings.

Item	Description
Location Name/ Device Name	Displays and defines the location name (infoPlayer) or name of the meeting room managed. This is mainly used for marking, helps to locate devices through Unizon using the search function. For more information please refer the to <i>Unizon user manual</i> .
IP Address	<ul style="list-style-type: none"> ◆ Displays the IP address of the infoPlayer/RBS Panel. ◆ Click  to optionally adjust the network settings of the RBS Panel/infoPlayer.
MAC	Displays the MAC address of the infoPlayer/RBS Panel.
Panel Password	Type the password of the infoPlayer/RBS Panel for the required authentication prior to uploading setting changes to the RBS Panel/infoPlayer. (default password: <i>password</i>)
Current Calendar	<i>This column is only applicable to RBS panels.</i> Displays the calendar server currently used to manage the RBS Panel.
Room Name Setting	<i>This column is only applicable to RBS panels.</i> Selects how the RBS Panel is named, either synchronized from the calendar or synchronized from the Unizon server.
Calendar Account	<p><i>This column is only applicable to RBS panels.</i></p> <ul style="list-style-type: none"> ◆ Displays the calendar server resource account used to manage the RBS Panel. ◆ Click  to configure the following settings: <ul style="list-style-type: none"> ◆ Reassign the calendar server resource account. ◆ Add a custom break symbol to split room name (see <i>Splitting Room Name using Break Symbol</i>, page 138). <p>Note: Make sure that all RBS Panels installed in the same Unizon room use the same resource account for their managing calendar server.</p>
Calendar Connection	<i>This column is only applicable to RBS panels.</i> Displays the connection status of the panel to the selected calendar server.
Profile	Displays the profile templates in a drop-down menu for switching.

Item	Description
Identity Checkup	<p><i>This column is only applicable to RBS panels.</i></p> <p>Displays or changes the identity checkup method for room check-in.</p> <ul style="list-style-type: none"> ◆ None: Does not require identity checkup for the scenarios selected in the Allow Identity Checkup When option. ◆ PIN: Requires a PIN (via the RBS panel) for the scenarios selected in the Allow Identity Checkup When option. ◆ Scan: Requires a valid access card for the scenarios selected in the Allow Identity Checkup When option. ◆ Scan + PIN: Requires both a valid access card and a PIN for the scenarios selected in the Allow Identity Checkup When option. <p>Note: For PIN, Scan, and Scan + PIN, these options are only available and configured through ATEN Unizon. For more information, see <i>ATEN Unizon User Manual</i>.</p>
Allow Identity Checkup When	<p><i>This column is only applicable to RBS panels and Identity Checkup is enabled.</i></p> <p>Displays or changes the identity checkup method for room check-in, check-out, release, and extension.</p> <ul style="list-style-type: none"> ◆ Check-in: Requires identity checkup for room check-in. This is the default setting. ◆ Check-out: Requires identity checkup for room check-out. ◆ Release: Requires identity checkup for room release. This is the default setting. ◆ Extend: Requires identity checkup for room extension.
Sign-on Confirmation	<ul style="list-style-type: none"> ◆ <i>This column is only applicable to RBS panels and only available when the identity checkup setting (see above) is enabled.</i> ◆ Displays or disables/enables the sign-on confirmation setting. Sign-on confirmation is a post-meeting, system generated attendance record (e-mail) sent to meeting attendees who have signed on (with the required identity checkup action). A sign-on confirmation contains a list of attendees' names, e-mail addresses, and the check-in time.

Item	Description
Allow Check-in From	<ul style="list-style-type: none"> ◆ <i>This column is only applicable to RBS panels and only available when identity checkup is enabled.</i> ◆ Displays or configures the privilege for room check-in. <ul style="list-style-type: none"> ◆ meeting host: The person who sends the meeting invite has privilege to check in the room. ◆ meeting host & invitees: The person who sends the meeting invite and the people who receive the invite have privilege to check in the room. ◆ anyone with entry privilege to the room: The people that are added as a group have privilege to check in the room, configured through ATEN Unizon. For more information, see <i>ATEN Unizon User Manual</i>.
Volume	Displays or adjusts the volume of the infoPlayer/RBS Panel.
Brightness	<i>This column is only applicable to RBS panels.</i> Displays or adjusts the brightness of the RBS Panel.
Language	Displays or adjusts the language setting of the infoPlayer/RBS Panel.
Time Zone	Displays or adjusts the time zone of the infoPlayer/RBS Panel.
FW / APP Version	Respectively displays the version of the infoPlayer/RBS Panel firmware and the RBS App.
Change Password	Click  to change the password of the infoPlayer/RBS Panel.
Automation	Provides access to start a reboot or sets scheduled reboots of the infoPlayer/RBS panel.
Last Update	Displays the time at which the infoPlayer/RBS Panel was last updated.

Adding RBS Panels to infoPlayer

For infoPlayer to synchronize with RBS panels and display room reservation information, add the RBS panels of the target rooms to the infoPlayer in the Device Configuration list.

1. In RBS Configuration, go to **Device Configuration > infoPlayer**. If your target infoPlayer device is not shown, click **Search** to add the device.
2. Click to select the target infoPlayer.

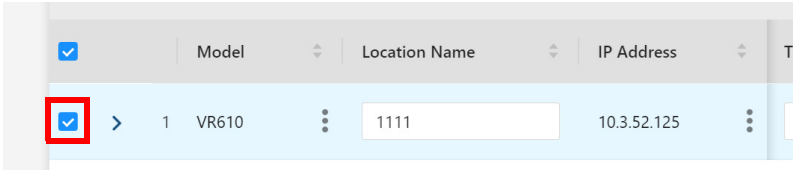

3. Click the arrow and click the **Add Device** button.

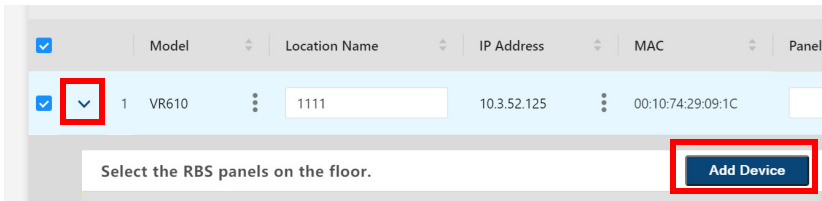

4. Follow the on-screen instructions to add RBS panels.

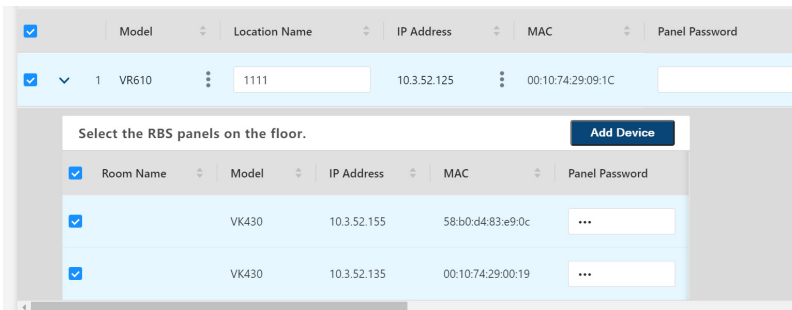

5. For the changed settings to take effect, upload the profile to the target infoPlayer. For details, see *Uploading Profiles to infoPlayer/RBS Panels*, page 169.

Uploading Profiles to infoPlayer/RBS Panels

Users can upload profiles and/or setting changes to any infoPlayer/RBS Panel managed by doing the following:

1. Load the target devices into RBS Configurator. For detailed steps, see *Loading Devices to RBS Configurator*, page 163.
2. Click to select the infoPlayer/RBS Panels to which you want to upload profiles and/or setting changes.

<input checked="" type="checkbox"/>	Model	Room Name	IP Address
<input checked="" type="checkbox"/>	1 VK430	601 Conference Room	10.3.66.21
<input type="checkbox"/>	2 VK430	602 Conference Room	10.3.66.20
<input checked="" type="checkbox"/>	3 VK430	605 Conference Room	10.3.66.18

3. To upload profiles, select the desired profile(s) from the drop-down list in the **Profile** column, as illustrated below.

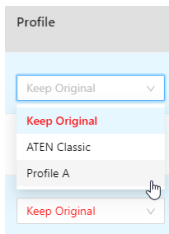

Note: Select **Keep Original** only when you don't want to replace the RBS Panel's current profile with another.

4. Make all of the setting changes you want to apply to the infoPlayer/RBS Panels selected.

5. Type the access key or the login passwords of the devices selected in the Password/Panel Password column, as illustrated below.

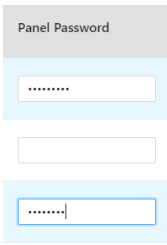

The screenshot shows a form with three input fields. The top field is labeled "Panel Password" and contains a series of dots. Below it is an empty input field. The bottom field is also labeled "Panel Password" and contains a series of dots followed by a vertical cursor.

Note: If the infoPlayer/RBS Panels to which you want to upload profiles and/or setting changes share the same panel password, you can simply type that common password in the Batch Password Authentication field instead of having to type the same password repeatedly.

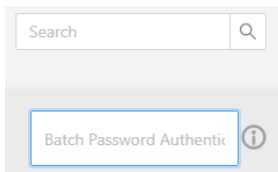

The screenshot shows a search bar with the text "Search" and a magnifying glass icon. Below it is a field labeled "Batch Password Authentication" with an information icon to its right. The "Batch Password Authentication" field is highlighted with a blue border.

6. Click **Upload**.

Batch Configure

The *Batch Config* function allows you to upload the same profile or apply same setting changes to multiple infoPlayer/RBS Panels all at once, instead of having to make the same setting changes individually and repeatedly.

1. Click to select the infoPlayer/RBS Panels to which you want to batch configure.

<input type="checkbox"/>	Model	Room Name	IP Address
<input checked="" type="checkbox"/>	1 VK430	601 Conference Room	10.3.66.21
<input type="checkbox"/>	2 VK430	602 Conference Room	10.3.66.20
<input checked="" type="checkbox"/>	3 VK430	605 Conference Room	10.3.66.18

2. Type the access key/login passwords of the infoPlayer/RBS Panels selected in the **Panel Password** column, as illustrated below.

Panel Password

.....

.....|

Note: If the RBS Panels to which you want to upload profiles and/or setting changes share the same panel password, you can simply type that common password in the **Batch Password Authentication** field instead of having to type the same password repeatedly.

Search Q

Batch Password Authentic i

3. Select the same setting changes and/or profile you want to apply to the infoPlayer/RBS Panels selected in **Batch Config**.

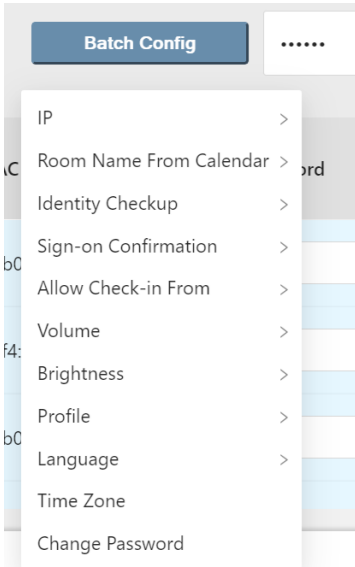

Note: The available options differ for infoPlayer and RBS Panels.

4. After all of the desired setting changes have been made, click **Upload** for them to be applied to the infoPlayer/RBS Panels selected.

Upgrading the RBS Panel Firmware

To upgrade the RBS panel firmware, follow the steps below.

Note: Make sure that the RBS panel receives adequate power supply (DC12V,17.8W, 60.70BTU or PoE 20W, 68.24BTU). With inadequate power supply, processes such as firmware upgrades and app updates may fail.

1. Download the firmware package from the VK430 product page.
2. Unzip the downloaded firmware package.
3. Upgrade using a USB drive or through the RBS Configurator.
 - ◆ **Using a USB drive**
 - (a) In the unzipped package, locate the *update.zip* file in the SD_Upgrade folder and save it to the root directory of a USB drive, e.g. E:/.
 - (b) Insert the USB drive to the USB Type-A port of the RBS Panel.
 - (c) Press the **Function** button to access the **Settings** page.
 - (d) Tap **System > System Updates**.
 - (e) Follow the on-screen instructions to upgrade the firmware.
 - ◆ **Via RBS Configurator**
 - (a) In RBS Configurator, go to **Device Configuration > Room Panel**, and then select the RBS Panels for which you want to upgrade firmware.

<input type="checkbox"/>	Model	Room Name	IP Address
<input checked="" type="checkbox"/>	1 VK430	601 Conference Room	10.3.66.21
<input type="checkbox"/>	2 VK430	602 Conference Room	10.3.66.20
<input checked="" type="checkbox"/>	3 VK430	605 Conference Room	10.3.66.18

(b) Type the login passwords of the selected RBS Panels in the Panel Password column, as illustrated below.

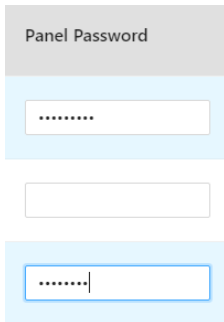

The screenshot shows a form with a header labeled "Panel Password". Below the header is a text input field containing seven asterisks. Below this field is an empty text input field. At the bottom of the form is another text input field containing seven asterisks and a vertical cursor.

Note: If the RBS Panels share the same panel password, you can simply type that common password in the **Batch Password Authentication** field instead of having to type the same password repeatedly.

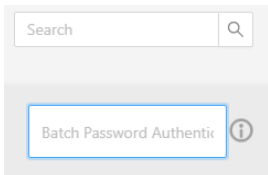

The screenshot shows a search bar at the top with the text "Search" and a magnifying glass icon. Below the search bar is a text input field containing the text "Batch Password Authentic" followed by a small circular information icon.

(d) Click **Upgrade**, select **FW Upgrade** and browse for the firmware file, *update.zip*.

(e) Click **Upgrade** to finish.

Upgrading the infoPlayer Firmware via RBS Configurator

1. Download the firmware package from the VR610 product page.
2. Unzip the downloaded firmware package.
3. In RBS Configurator, go to **Device Configuration > infoPlayer**.
4. Select the infoPlayer device(s) for which you want to upgrade firmware.

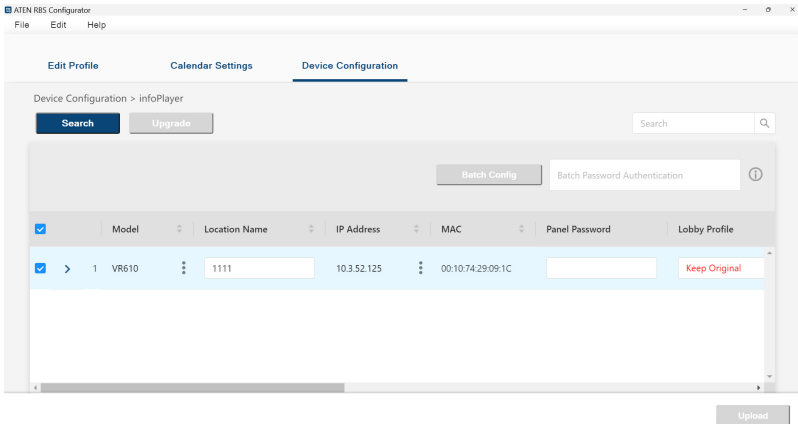

5. Type the login passwords of the selected infoPlayer device in the Password column, as illustrated below.

Panel Password

.....

.....|

Note: If you have selected two or more infoPlayer devices that share the same password, type that common password in the **Batch Password**

Authentication field instead of having to type the same password repeatedly.

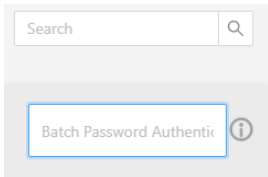

-
6. Click **Upgrade**, select FW Upgrade and browse for the firmware file, *update.zip*.
 7. Click **Upgrade** to finish. The connected monitor blinks twice to indicate that the upgrade is successful.

Recovery Mode for infoPlayer

If the firmware upgrade fails and you are unable to locate the device's IP address, use the recovery mode to restore connectivity and resolve the issue. To enter the recovery mode, follow the steps below.

1. Power off the unit.
2. Press and hold the reset button and then power on the unit. The reset button is located on the bottom of the unit.

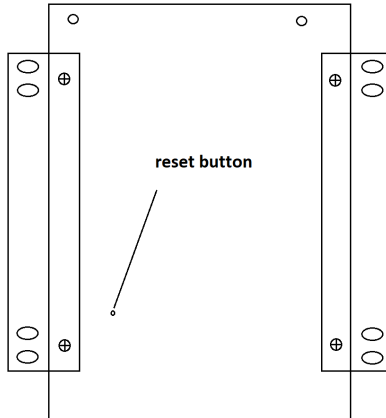

3. Wait for 5 seconds to enter the recovery mode. The HDMI output will display a recovery mode screen.
4. Under the recovery mode, the IP address is set to DHCP mode, which means you will be able to find the unit via RBS Configurator. Use the default password for login.
5. Go to RBS Configurator to locate the unit, and click **Panel Reset to Default**.
6. After default, power off and then power on the unit.

Updating the RBS Panel App

To update RBS panel app, follow the steps below.

Note: Make sure that the RBS panel receives adequate power supply (DC12V,17.8W, 60.70BTU or PoE 20W, 68.24BTU). With inadequate power supply, processes such as firmware upgrades and app updates may fail.

1. Download the RBS app package from the VK430 product page.
2. Unzip the downloaded package.
3. In RBS Configurator, go to **Device Configuration** and select the RBS Panels for which you want to update the app.

	Model	Room Name	IP Address
<input checked="" type="checkbox"/>	1 VK430	601 Conference Room	10.3.66.21
<input type="checkbox"/>	2 VK430	602 Conference Room	10.3.66.20

4. Type the login passwords of the RBS Panels selected in the Panel Password column, as illustrated below.

Panel Password

.....

.....

Note: If the RBS Panels share the same panel password, you can simply type that common password in the **Batch Password Authentication** field instead of having to type the same password repeatedly.

Search

Batch Password Authentication

5. Click **Upgrade**, select **App Upgrade**, and browse for the app file, *RoomBookingSystem_Vx.x.xxx.apk*.
6. Click **Upgrade** to finish.

Managing Login Password Setting Panel Passwords

Panel Login

To start, make sure the RBS Panel is connected to the network and turned on.

1. From its main page, tap . The login page appears.

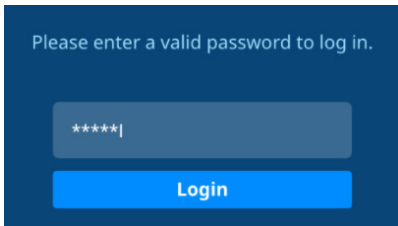
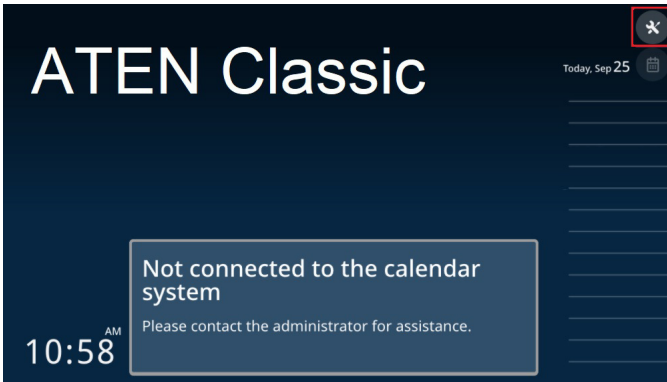

2. Log into the RBS Panel by entering its password and tapping **Login**.

Note: For first-time login, use the default password *password* to log in, and you're required to change the password.

3. Once logged in, you can change the panel's password by tapping **Change Password** and following the on-screen instructions.
4. Tap **Save** to finish.

Changing Panel Passwords

You can change the password of one RBS panel or multiples by batch.

■ Changing the Password of One RBS Panel via the Panel

1. On the main page of the RBS panel, tap . The General settings page appears.
2. Tap **Password** on the left to change the password.
3. Clive **Save** to apply the change.

■ Changing the Passwords of Multiple RBS Panels by Batch

To start, make sure all of the RBS Panels to be configured are connected within the same network as your ATEN RBS Configurator and turned on.

1. On your RBS Configurator, go to the **Device Configuration** tab and search for the RBS Panels you want to change passwords for by 1 of the 2 following methods.
 - ◆ **Auto Scan:** Automatically searches for all RBS Panels within the same subnet.
 - ◆ **By IP:** Searches for RBS Panels within the LAN by entering an IP range or a specific IP address.
2. Check the RBS Panels for which you want to change passwords.

<input checked="" type="checkbox"/>	Model	Room Name	IP Address
<input checked="" type="checkbox"/>	1 VK430	601 Conference Room	10.3.66.21
<input type="checkbox"/>	2 VK430	602 Conference Room	10.3.66.20
<input checked="" type="checkbox"/>	3 VK430	605 Conference Room	10.3.66.18

3. Type the login passwords of the RBS Panels selected in the **Panel Password** column, as illustrated below.

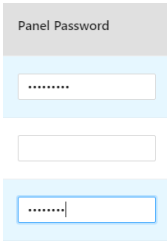

A screenshot of a form titled "Panel Password". It contains two input fields. The first field is highlighted with a blue border and contains a series of dots. The second field is empty and also has a blue border.

Note: If the RBS Panels to which you want to upload profiles and/or setting changes share the same panel password, you can simply type that common password in the **Batch Password Authentication** field instead of having to type the same password repeatedly.

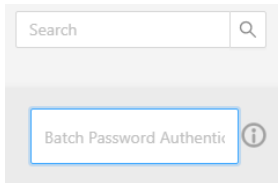

A screenshot of a form element titled "Batch Password Authentication" with an information icon. Above it is a search bar with the text "Search" and a magnifying glass icon.

4. Click **Batch Config > Change Password**, set a password, and click **Fill in**

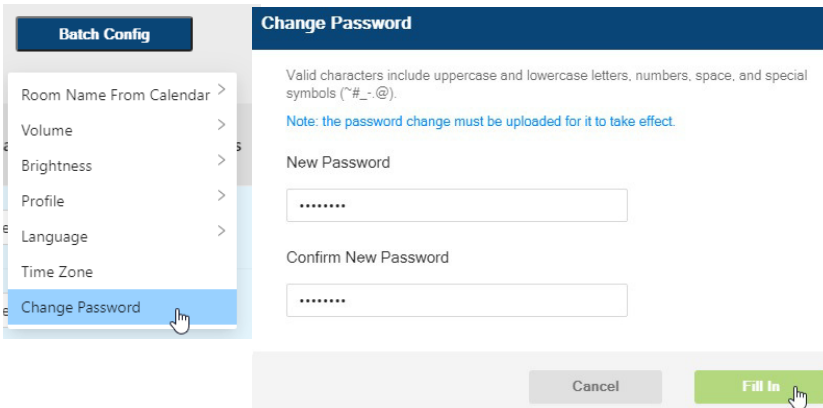

A screenshot of the "Batch Config > Change Password" interface. On the left, a "Batch Config" menu is open, showing options like "Room Name From Calendar", "Volume", "Brightness", "Profile", "Language", "Time Zone", and "Change Password" (which is highlighted with a blue bar and a mouse cursor). The main area is titled "Change Password" and contains the following text: "Valid characters include uppercase and lowercase letters, numbers, space, and special symbols (~#_-.@).", a note: "Note: the password change must be uploaded for it to take effect.", and two input fields labeled "New Password" and "Confirm New Password", both containing dots. At the bottom, there are two buttons: "Cancel" and "Fill In" (highlighted in green with a mouse cursor).

Click **Upload** to apply the password change to the RBS Panels selected.

Managing infoPlayer via the Web Console

The ATEN infoPlayer can be configured from its web console over a standard TCP/IP connection. Because it can be accessed from anywhere over a network or the Internet, system administrators can easily log in via a web browser.

The infoPlayer *web console* allows you to:

- ◆ Change general settings such as device name, time, and network settings
- ◆ Upgrade device firmware
- ◆ Export logs
- ◆ Change the access key (password)
- ◆ Change display resolutions
- ◆ Upload SSL certificate

Web Console Overview

Access the web console by logging in with the device IP address and login credentials. The dashboard appears, as shown below.

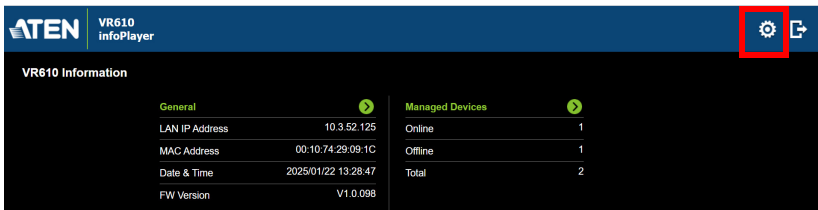

To go to the settings page, click . The General settings page appears.

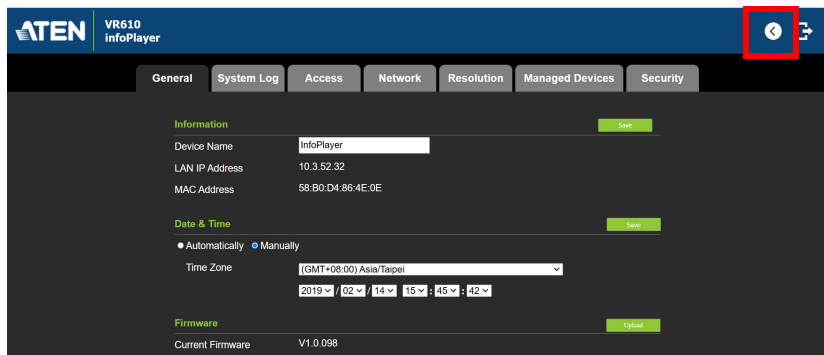

To return to the dashboard, click  from the toolbar.

The Dashboard

Use the dashboard to look up the following information:

- ◆ Device IP address and MAC address
- ◆ Firmware version
- ◆ Connection status of managed devices

The Dashboard:

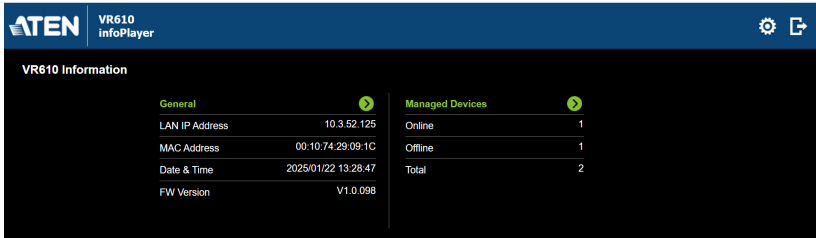

To access the dashboard, log in the web console and the dashboard opens by default. If you are already logged in, click  from the toolbar to return to the dashboard.

General Settings

Use the General settings page to configure device name, system time settings, or upgrade system firmware.

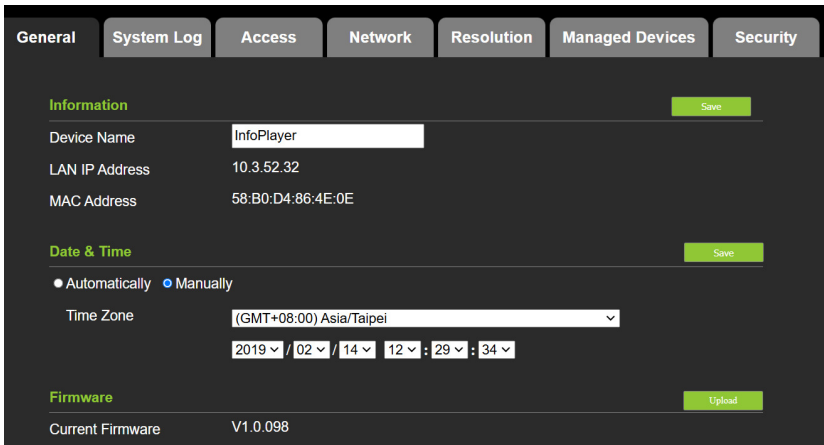

- ◆ **Information**

- ◆ **Device name:** Type to modify device name. The default name is **infoPlayer**.
- ◆ **LAN IP Address:** Indicates the device IP address.
- ◆ **MAC Address:** Indicates the device MAC address.

- ◆ **Date & Time**

- ◆ **Automatically:** Select this option for the device to automatically synchronizes the date and time of the specified time zone and NTP server.
 - ◆ **Time Zone:** Select a time zone. Choose the city that most closely corresponds to where it is located.

How to Configure NTP Server Settings

Assign an NTP server for the device to synchronizes its clock. If the device has access to the Internet, configure the **Preferred NTP Server** and **Alternate NTP Server** settings. If the device is installed in a closed network, configure the **Preferred Customer Server IP** and **Alternate Customer Server IP** settings.

- ◆ **Preferred NTP Server:** Select an NTP server to provide synchronization services to the device. Make sure to use an NTP server that is located close to where the device is installed to minimize propagation delays.
 - ◆ **Alternate NTP Server:** Select an alternate NTP server to which the device connects when it is unable to connect to the preferred NTP server.
 - ◆ **Preferred Customer Server IP:** Select this option to use a private NTP server if the device is installed in a closed network.
 - ◆ **Alternate Customer Server IP:** Select this option to set up a substitute server if the device is unable to connect to the preferred server.
 - ◆ **Adjust Time:** Sets the interval at which the device synchronizes its clock with the assigned NTP server.
 - ◆ **Manually:** The device synchronizes its system with the selected time zone or the specified time.
- ◆ **Firmware**
 - ◆ Indicates the device firmware version
 - ◆ To change the firmware version, click **Upload** and follow the on-screen instructions to complete the upgrade.

Exporting System Logs

To export system logs:

1. From web console toolbar, click  to go to the Settings page.
2. Click **System Log**. This page appears.

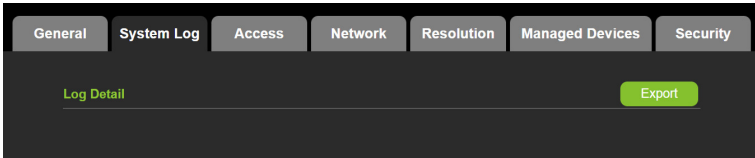

3. Click **Export**. A log file automatically downloads.

Configuring the Access Key and Lock Settings

To change the access key, or to set up account lockout to prevent brute-force attacks:

1. In the infoPlayer web console, visit the Access settings page.
 - ◆ In the infoPlayer web console, click the **Access** tab, or
 - ◆ From the dashboard page, click  and then click the **Access** tab.

This page appears.

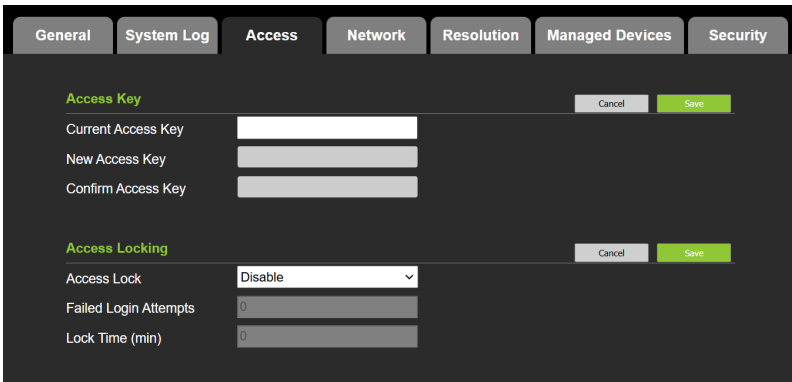

2. To change the access key:
 - a) Type the current and new access key.
 - b) Confirm the new access key.
 - c) Click **Save** to apply the settings. The new access key takes effect from the next login.

3. To set up account lockout:
 - a) Enable **Access Lock**.
 - b) Specify the **Failed Login Attempts** and the **Lock Time**.
 - c) Click **Save** to apply the configuration.

Configuring the Device Network Settings

The infoPlayer uses DHCP to automatically receive IP address. To manually configure the network settings, follow the steps below.

1. From web console toolbar, click  to go to the Settings page.
2. Click the **Network** tab. This page appears.

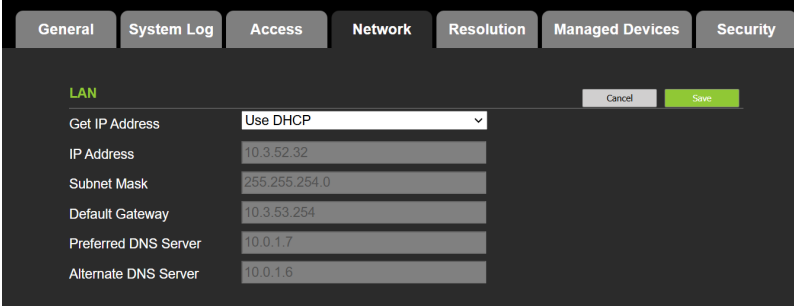

The screenshot shows the 'Network' tab selected in the top navigation bar. Below the tabs, the 'LAN' section is visible. The 'Get IP Address' dropdown menu is set to 'Use DHCP'. Other fields include IP Address (10.3.52.32), Subnet Mask (255.255.254.0), Default Gateway (10.3.53.254), Preferred DNS Server (10.0.1.7), and Alternate DNS Server (10.0.1.6). There are 'Cancel' and 'Save' buttons on the right.

3. Click the **Get IP Address** drop-down list, and select **Manually (DHCP off)**.

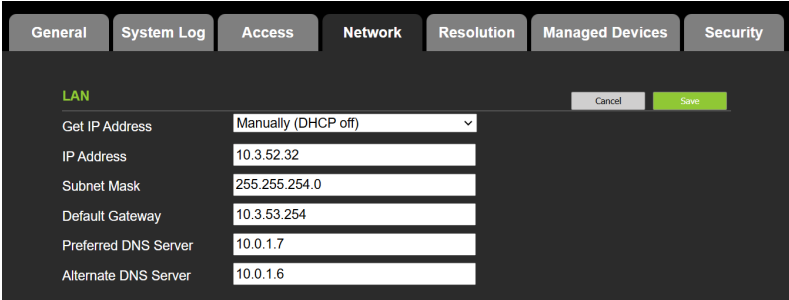

The screenshot shows the 'Network' tab selected. The 'Get IP Address' dropdown menu is now set to 'Manually (DHCP off)'. The other fields remain the same: IP Address (10.3.52.32), Subnet Mask (255.255.254.0), Default Gateway (10.3.53.254), Preferred DNS Server (10.0.1.7), and Alternate DNS Server (10.0.1.6). There are 'Cancel' and 'Save' buttons on the right.

4. Type in the IP address, subnet mask, default gateway, preferred DNS server, and alternative DNS server.
5. Click **Save** to apply the settings.

Configuring Display Resolution and Rotation

To configure the resolution and degrees of rotation for the connected display:

1. From web console toolbar, click  to go to the Settings page.
2. Click the **Resolution** tab. This page appears.

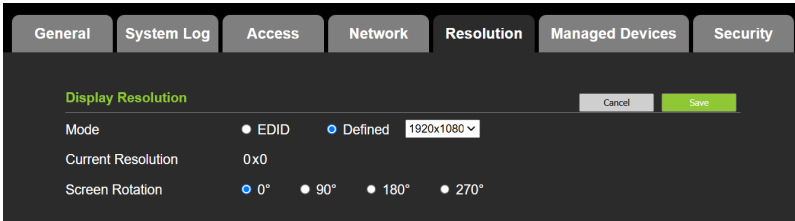

3. Configure the following settings as required.

- ◆ **Mode**
 - ◆ **EDID:** Select this option for infoPlayer to automatically detect the resolution of the connected display.
 - ◆ **Defined:** Select this option to use a specific, defined resolution.
- ◆ **Current Resolution:** Indicates the resolution of the connected display.
- ◆ **Screen Rotation:** Defines the degree of display rotation in clockwise direction.

Viewing the Connection Status of RBS Panels

To see the connection status of the RBS panels from the infoPlayer web console, go to **dashboard** or the **Managed Devices** tab:

- ◆ Dashboard

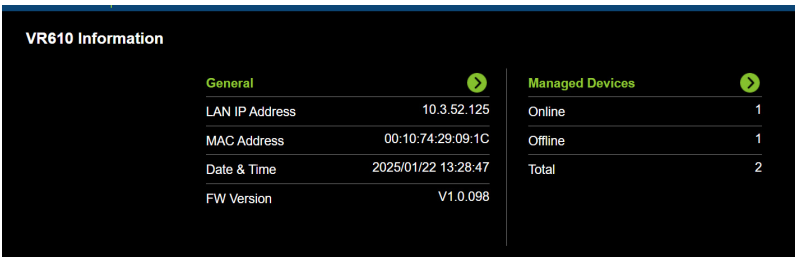

- ◆ **Managed Devices tab:** From the web console toolbar, click  to go to the Settings page, and then click the **Managed Devices** tab.



Connection Room Panel		
Room Name	IP Address	Status
#1 测试	10.3.52.155	● Online
#2 10.3.52.135	10.3.52.135	○ Offline

Enabling SSL

Enable SSL settings to secure the browsing sessions between your computer and the infoPlayer's web interface. To enable SSL encryption on the infoPlayer, purchase and obtain an SSL certificate from a trusted certifying authority and upload the certificate to the infoPlayer.

To upload the SSL certificate:

1. From web console toolbar, click  to go to the Settings page.
2. Click the **Security** tab. This page appears.

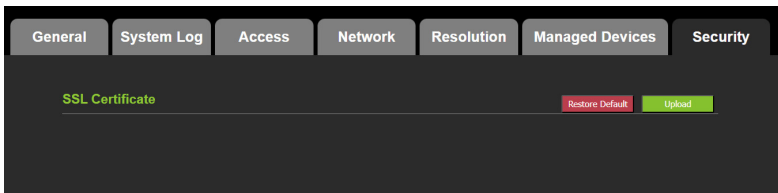

3. Click **Upload** to apply the certificate.

This Page Intentionally Left Blank

Appendix

Safety Instructions

General

- ◆ Read all of these instructions. Save them for future reference.
- ◆ Follow all warnings and instructions marked on the device.
- ◆ This product is for indoor use only.
- ◆ Do not place the device on any unstable surface (cart, stand, table, etc.). If the device falls, serious damage will result.
- ◆ Caution: Risk of explosion if the battery is replaced by an incorrect type. Always dispose of used batteries according to the proper instructions.
- ◆ Do not use the device near water.
- ◆ Do not place the device near, or over, radiators or heat registers.
- ◆ The device cabinet is provided with slots and openings to allow for adequate ventilation. To ensure reliable operation, and to protect against overheating, these openings must never be blocked or covered.
- ◆ The device should never be placed on a soft surface (bed, sofa, rug, etc.) as this will block its ventilation openings. Likewise, the device should not be placed in a built in enclosure unless adequate ventilation has been provided.
- ◆ Never spill liquid of any kind on the device.
- ◆ Unplug the device from the wall outlet before cleaning. Do not use liquid or aerosol cleaners. Use a damp cloth for cleaning.
- ◆ The device should be operated from the type of power source indicated on the marking label. If you are not sure of the type of power available, consult your dealer or local power company.
- ◆ To prevent damage to your installation it is important that all devices are properly grounded.
- ◆ Do not allow anything to rest on the power cord or cables. Route the power cord and cables so that they cannot be stepped on or tripped over.
- ◆ Position system cables and power cables carefully; Be sure that nothing rests on any cables.
- ◆ Never push objects of any kind into or through cabinet slots. They may touch dangerous voltage points or short out parts resulting in a risk of fire or electrical shock.

- ◆ Do not attempt to service the device yourself. Refer all servicing to qualified service personnel.
- ◆ If the following conditions occur, unplug the device from the wall outlet and bring it to qualified service personnel for repair.
 - ◆ The power cord or plug has become damaged or frayed.
 - ◆ Liquid has been spilled into the device.
 - ◆ The device has been exposed to rain or water.
 - ◆ The device has been dropped, or the cabinet has been damaged.
 - ◆ The device exhibits a distinct change in performance, indicating a need for service.
 - ◆ The device does not operate normally when the operating instructions are followed.
- ◆ Only adjust those controls that are covered in the operating instructions. Improper adjustment of other controls may result in damage that will require extensive work by a qualified technician to repair.
- ◆ Avoid circuit overloads. Before connecting equipment to a circuit, know the power supply's limit and never exceed it. Always review the electrical specifications of a circuit to ensure that you are not creating a dangerous condition or that one doesn't already exist. Circuit overloads can cause a fire and destroy equipment.

Troubleshooting

Microsoft 365 & Exchange

Meeting Title and Details Cannot Be Shown on RBS Panels

If you encounter this issue, please follow the steps below to resolve it.

1. Connect to **PowerShell**.
 - a) For Microsoft 365: Connect to **PowerShell** and make sure the *Administrator: Windows Power Shell* appears in the title bar. If *Windows PowerShell* appears in the title bar instead, right-click on the **PowerShell** icon in the bottom bar and then click **Run as Administrator**, then proceed to step 2 and the following steps.
 - b) For all Microsoft Exchange: Open **Exchange Management Shell** from Start, then proceed to step 9 and the following steps.
2. Copy and paste the text `Set-ExecutionPolicy RemoteSigned` to change the execution policy setting.
3. Type **Y** to agree changing the execution policy.
4. Copy and paste the text `[Net.ServicePointManager]::SecurityProtocol=[Net.SecurityProtocolType]::Tls12` to set security protocol.
5. Copy and paste the text `Install-Module-Name ExchangeOnlineManagement` to install Exchange Online Module.
6. Type **Y** to accept installing the module.
7. Copy and paste the text `Import-Module ExchangeOnlineManagement` to use Exchange Online Module.
8. Copy and paste the text `Connect-ExchangeOnline` to log in to the Exchange Online from the pop-up window by using admin account and password.
9. Copy and paste the text `Get-CalendarProcessing-Identity "roomname" | FL` to check the settings.

Note: The "**roomname**" is used as an example here.

10. Copy and paste the text `Get-CalendarProcessing-Identity "roomname"-DeleteComments$False-DeleteSubject$False-AddOrganizerToSubject$False` to modify the settings to **False**.

Note: The “[roomname](#)” is used as an example here.

DeleteComments: False

DeleteSubject: False

AddOrganizerToSubject: False

11. Copy and paste the text `Get-CalendarProcessing-Identity
"roomname"| FL` to check if the settings are false. Repeat step 9 to 11 for each resource account.

Note: The “[roomname](#)” is used as an example here.

Specifications

VK401

Mode of Operation (Frequency)	
13.56 MHz	
Interface	
Connector Type	Pogo pin
Industrial Protocols	
ISO 14443A/B, ISO 15693, Mifare, Felica (Card UID)	
Sensing Distance	
Up to 30 mm (depends on the tag type)	
Environmental	
Operational Temperature	0 – 40 °C
Physical Properties	
Housing	Plastic
Weight	36 g
Dimensions (L x W x H)	5.60 x 7.00 x 2.33 cm

VK430

Processor	
Quad-core	
Memory	
SDRAM	2 GB
Flash	16 GB
Panel Specifications	
Display Type	TFT-LCD
Size	10.1"
Touch Screen	Capacitive
Resolution	1280 x 800
Aspect Ratio	16:10

Color Depth	8 bit
Contrast Ratio	800:1
Backlight	LED
Viewing Angle	±85° (H), ±85° (V)
Luminance	500 cd/m ²
Interfaces	
Ethernet	1 x RJ-45 Female, 10/100/1000 BaseT
USB	1 x USB Type-A
Power	
Power over Ethernet (PoE)	802.3 at PoE+
Power Consumption	DC12V:17.8W:60.70BTU PoE: 20 W : 68.24 BTU
Environmental	
Operating Temperature	0 – 40 °C
Storage Temperature	-10 – 55 °C
Humidity	10–80% RH, Non-condensing
Physical Properties	
Housing	Plastic
Weight	0.68 kg (1.5 lb)
Dimensions (L x W x H)	26.30 x 17.78 x 2.45 cm (10.35 x 7.00 x 0.96 in.)

Note:

No license is required for running ATEN Room Booking System. However, additional costs may be charged for the resource accounts by the calendar service provider.

VR610

Component		
Processor		Dual CPU
Memory	SDRAM	4GB
	Flash	16GB
Interfaces		
Video Input		1 x Mini HDMI Female; Support up to 1080P@60Hz
Video Output		1 x Standard HDMI Female; Support up to 4K@60Hz
USB		USB 2.0 TYPE A X1 USB 3.0 TYPE A X1 TYPE C—Support OTG
I/O		1 x Mini Stereo Jack Female (PIR sensor)
Ethernet		1 x RJ-45 Female, 10 / 100 / 1000 BaseT
USB		1 x USB 2.0 Type-A 1 x USB 3.0 Type-A 1 x USB Type-C
Power Inputs		
Power over Ethernet (PoE)		802.3 at PoE+
Power Consumption		
DC12V:18.04W:61.5BTU/h		
PoE:20.3W:69.27BTU/h		
Note:		
<ul style="list-style-type: none"> ◆ The measurement in Watts indicates the typical power consumption of the device with no external loading. ◆ The measurement in BTU/h indicates the power consumption of the device when it is fully loaded. 		
Environmental		
Operating Temperature		0 – 40 °C
Storage Temperature		-20 – 60°C
Humidity		10–85% RH, Non-condensing
Physical Properties		
Housing		Metal
Weight		0.5 kg (1.1 lb)
Dimensions (L x W x H)		15.31 x 13.34 x 3.06 cm (6.03 x 5.25 x 1.2 in.)

Input Resolutions

640x480 @ 60/67/72/75 Hz
720x400 @ 70 Hz
800x600 @ 56/60/72/75 Hz
1024x768 @ 60/70/75 Hz
1280x800 @ 60 Hz
1280x1024 @ 60/75 Hz
1400x1050 @ 60 Hz
1440x900 @ 60 Hz
1600x1200 @ 60 Hz
1680x1050 @ 60 Hz
1920x1080 @ 60/120/240 Hz
1920x1200 @ 60 Hz/60 Hz (Reduced Blanking)
1080p 60 Hz
480p 60 Hz (4:3) / (16:9)
720p 60 Hz
1080i 60 Hz
640x480 @ 60Hz (4:3)
576p 50 Hz (4:3)/(16:9)
720p 50 Hz
1080i 50 Hz
1080p 24/25/30/50 Hz
3840x2160p 24/25/30/50/60 Hz
1920x1080 @ 144 Hz
2560x1440 @ 144 Hz

Technical Support

International

- ◆ For online technical support – including troubleshooting, documentation, and software updates: <http://eservice.aten.com>
- ◆ For telephone support, see *Telephone Support*, page iv:

North America

Email Support		support@aten-usa.com
Online Technical Support	Troubleshooting Documentation Software Updates	https://eservice.aten.com
Telephone Support		1-888-999-ATEN ext 4988

When you contact us, please have the following information ready beforehand:

- ◆ Product model number, serial number, and date of purchase.
- ◆ Your computer configuration, including operating system, revision level, expansion cards, and software.
- ◆ Any error messages displayed at the time the error occurred.
- ◆ The sequence of operations that led up to the error.
- ◆ Any other information you feel may be of help.

ATEN Warranty Policy

The warranty policy may vary by product category and region of purchase. For details, please visit ATEN's official website, select your purchase counties/regions and then go to the Support Center, or contact your local ATEN sales representative for further assistance.

© Copyright 2026 ATEN® International Co., Ltd.
Released: 2026-02-09

ATEN and the ATEN logo are registered trademarks of ATEN International Co., Ltd. All rights reserved. All other brand names and trademarks are the registered property of their respective owners.