



Simply Better Connections

VK1100A / VK1200 /
VK2100A / VK2200

Control Box Gen. 2
Setup Guide

Compliance Statements

FEDERAL COMMUNICATIONS COMMISSION INTERFERENCE STATEMENT

This equipment has been tested and found to comply with the limits for a Class A digital device, pursuant to Part 15 of the FCC Rules. These limits are designed to provide reasonable protection against harmful interference when the equipment is operated in a commercial environment. This equipment generates, uses, and can radiate radio frequency energy and, if not installed and used in accordance with the instruction manual, may cause harmful interference to radio communications. Operation of this equipment in a residential area is likely to cause harmful interference in which case the user will be required to correct the interference at his own expense.

The device complies with Part 15 of the FCC Rules. Operation is subject to the following two conditions: (1) this device may not cause harmful interference, and (2) this device must accept any interference received, including interference that may cause undesired operation.

FCC Caution

Any changes or modifications not expressly approved by the party responsible for compliance could void the user's authority to operate this equipment.

Warning

Operation of this equipment in a residential environment could cause radio interference.

Achtung

Der Gebrauch dieses Geräts in Wohnumgebung kann Funkstörungen verursachen.



KCC Statement

유선 제품용 / A 급 기기 (업무용 방송 통신 기기)
이 기기는 업무용 (A 급) 전자파적합기기로서 판매자 또는 사용자는 이
점을 주의하시기 바라며, 가정 외의 지역에서 사용하는 것을 목적으로
합니다.

Industry Canada Statement

This Class A digital apparatus complies with Canadian ICES-003.

CAN ICES-003 (A) / NMB-003 (A)

VCCI Statement

この装置は、クラスA機器です。この装置を住宅環境で使用すると電波妨害を引き起こすことがあります。この場合には使用者が適切な対策を講ずるよう要求されることがあります。

VCCI - A

RoHS

This product is RoHS compliant.

User Information

Online Registration

Be sure to register your product at our online support center:

International	http://eservice.aten.com
---------------	---

Telephone Support

For telephone support, call this number:

International	886-2-8692-6959
China	86-400-810-0-810
Japan	81-3-5615-5811
Korea	82-2-467-6789
North America	1-888-999-ATEN ext 4988 1-949-428-1111

User Notice

All information, documentation, and specifications contained in this manual are subject to change without prior notification by the manufacturer. The manufacturer makes no representations or warranties, either expressed or implied, with respect to the contents hereof and specifically disclaims any warranties as to merchantability or fitness for any particular purpose. Any of the manufacturer's software described in this manual is sold or licensed *as is*. Should the programs prove defective following their purchase, the buyer (and not the manufacturer, its distributor, or its dealer), assumes the entire cost of all necessary servicing, repair and any incidental or consequential damages resulting from any defect in the software.

The manufacturer of this system is not responsible for any radio and/or TV interference caused by unauthorized modifications to this device. It is the responsibility of the user to correct such interference.

The manufacturer is not responsible for any damage incurred in the operation of this system if the correct operational voltage setting was not selected prior to operation. PLEASE VERIFY THAT THE VOLTAGE SETTING IS CORRECT BEFORE USE.

Product Information

For information about all ATEN products and how they can help you connect without limits, visit ATEN on the Web or contact an ATEN Authorized Reseller. Visit ATEN on the Web for a list of locations and telephone numbers:

International	http://www.aten.com
North America	http://www.aten-usa.com

Conventions

Refer to the table below for the definition of frequently used terms.

Terminology	Definition
Control Box Gen. 2	Control Box Gen. 2 refers to ATEN VK1100A, VK1200, VK2100A, and VK2200.
controller	Controller refers to all models of ATEN Control Box Gen. 2 and Control Pad.

Contents

Compliance Statements	ii
User Information	iv
Telephone Support	iv
User Notice	iv
Product Information	v
Conventions	v
Contents	vi
1. Introduction	
Overview	1
Package Contents	1
Before You Start	2
Front Panel	4
VK1100A	4
VK1200	4
VK2100A	4
VK2200	5
Rear Panel	7
VK1200	7
VK2100A	7
VK2200	8
Overall Installation Procedure	10
2. Getting Started	
Placement	11
Rack Mount	11
VK2100A / VK2200	11
VK1100A / VK1200	13
Desktop	15
Powering the Control Box	16
3. Initialization	
ID, Network & License Configuration	17
Setting Control Box ID	17
Determining the IP Address	17
Changing Network Settings	19
IP Installer	19
Web Interface	19
Firmware	20

Upgrading Firmware	20
Licenses	21
Adding Licenses	21

4. Wiring

Wiring and Connecting to Devices	22
12 V DC Power Output	22
Independent Power Supply	23
Relay	24
Using Self-Supplied Power	24
Powered by 12 V DC Power Output	25
Application: Control Using External Relays	26
Digital I/O	27
Digital Input	27
Digital Output	28
Bidirectional Serial	31
RS-232 (3-Pin)	31
RS-232/422/485 (5-Pin)	32
Unidirectional IR / Serial	32
IR Connection	33
Serial Connection	33
Control LAN	34

5. Configuring a Profile

ATEN Configurator — VK6000	35
Adding the Control Box	35
ATEN Expansion Box	36

Appendix

Safety Instructions	37
Rack Mounting	39
Technical Support	40
Specifications	41
VK1100A	41
VK1200	44
VK2100A	47
VK2200	51
ATEN Warranty Policy	54

Chapter 1

Introduction

Overview

The Control Box Gen. 2 is an Ethernet-based controller device that connects and integrates a spate of devices to provide single-access configuration and convenient remote control for a room setting, such as boardrooms and lecture halls.

It offers multiple bidirectional serial ports, relays, IR/serial ports, digital I/O, and 12 V DC power output ports, as well as a dedicated control LAN port^{*}, separate from the corporate LAN, for IP device management within a secure subnetwork. In addition, it also supports a range of ATEN Expansion Boxes in providing versatile scalability.

Once successfully connected, users will be able to configure all in-room devices using the ATEN Configurator software — VK6000, and allow remote control using ATEN Touch Panel, ATEN Keypads, and Android / iOS / Windows mobile devices via the ATEN Control System app.

For a centralized management, the Control Box Gen. 2 can be connected to ATEN Unizon, a global AV management platform software, allowing users to control and monitor multiple ATEN Ethernet-based solutions across different locations, including but not limited to ATEN Control Boxes, at the same time.

Package Contents

Make sure the following are present and in working condition:

- 1 Control Box Gen. 2
- 1 power cord
- 1 foot pad set (4 pcs)
- 1 rack mount kit (VK2100A / VK2200 only)
- 1 user instructions

1 terminal block kit

Terminal Block	VK1100A / VK1200	VK2100A	VK2200
2-Pin	7	12	20
3-Pin	2	4	6
5-Pin	1	3	4

Before You Start

The following is a checklist of the items to prepare / consider before you start:

- Go through the numbers and types of ports available, and see if it satisfies all of the devices you want to be controlled within your room setting.

Interface		VK1100A	VK1200	VK2100A	VK2200
Bidirectional Serial	3-Pin RS-232	1		4	6
	5-Pin RS-232/422/485	1		2	2
Unidirectional IR/Serial		2		4	8
Relay		4		4	8
Digital I/O		2		4	8
12 V DC Output		1		4	4
Ethernet		1	2	1	2

Note: For more control port interfaces, up to 8 ATEN Expansion boxes per expander model can be connected to the Control Box. See *Compatible Products* on the product web page for details.

- Consider the recommended maximum length of each interface cable, as listed below, and choose an appropriate installation location for the Control Box.

Interface	Length (m)
RS-232	15
RS-422/485	350
Relay	30
I/O	30

Interface	Length (m)
IR	30

Note: The maximum allowed length of each interface cable may vary depending on the cable quality.

- Prepare a PC with the following specifications, which may be used to set the system settings of Control Box Gen. 2 and run VK6000.
 - ◆ Windows 7 / 8 / 8.1 / 10
 - ◆ Installed with .Net Framework V4.5 or later

- Take note of the network information and login credentials of each IP device that will be connecting to and managed by the Control Box, if any.

Front Panel

VK1100A

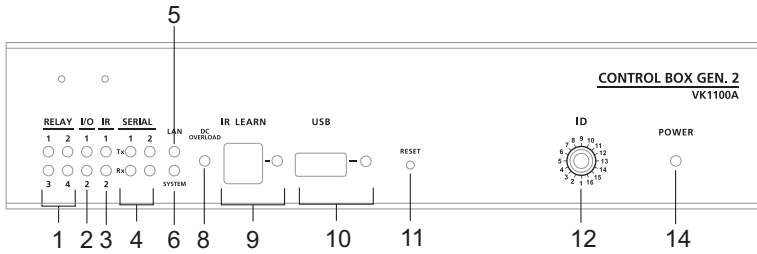

VK1200

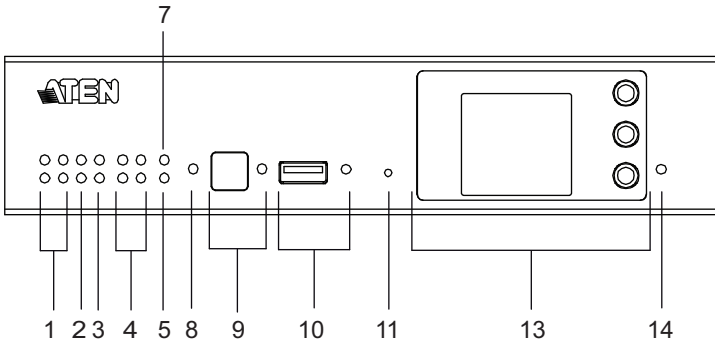

VK2100A

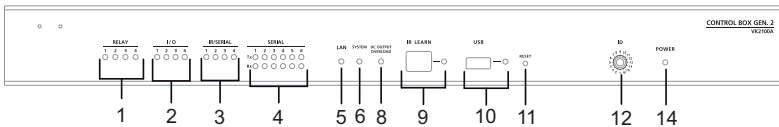

VK2200

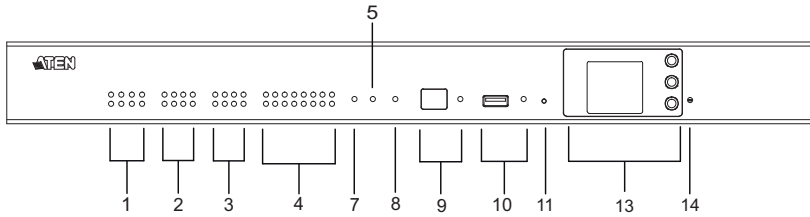

No.	Component	Description
1	relay LEDs	<ul style="list-style-type: none"> ♦ Lights green to indicate an active device connection or signals being transmitted. ♦ Blinks green once to indicate system startup, with the buzzer beeping once
2	I/O LEDs	
3	IR / serial LEDs	
4	serial LEDs	
5	LAN LED	Lights green to indicate successful connection to the network.
6	System LED	Blinks green to indicate that the system is running without issues.
7	Control LAN LED	Lights green to indicate successful connection to the network.
8	DC output overload LED	<p>Lights orange to indicate DC output exceeding the maximum output threshold, with the buzzer beeping for 3 seconds.</p> <p>Note: Please unplug any of the connected devices to keep its total output under 12 V DC, 1 A / 2A and restart the unit.</p>

No.	Component	Description
9	IR receiver / LED	<p>Passes the functions of a remote control to the Control Box in learning mode. The distance between the IR remote and the receiver window should be kept under 10 cm with a direct line of sight.</p> <ul style="list-style-type: none"> ◆ The LED blinks green to indicate the unit is receiving signals from an IR remote control ◆ The LED lights green to indicate entering learning mode, or IR learning success with the buzzer beeping once.
10	USB port / LED	<p>Note: Control Box Gen 2. is compatible with USB drivers in NTFS format only.</p> <p>Plugs in a USB device to upload Viewers (configured by the VK6000) to the Control Box.</p> <ul style="list-style-type: none"> ◆ The LED blinks green to indicate that Viewers are being uploaded, and lights green to indicate a successful upload, with the buzzer beeping once upon USB plug-in and once upon upload success. ◆ The LED lights orange to indicate upload failure, with the buzzer beeping 3 times for no available file found or upload failure.
11	reset button	<ul style="list-style-type: none"> ◆ Clear all settings but network, license, and firmware: Press and hold until the front panel LEDs blink once, with the buzzer beeping once (about 8 seconds). The LEDs and buzzer will trigger once more when the reset is complete. ◆ Reset network settings: Short press once. <p>Note: For more reset functions, please refer to the user manual.</p>
12	Control Box ID Switch	Use the switch to set an ID for the Control Box.
13	LCD panel and buttons	Use the <i>Up</i> , <i>Down</i> , and <i>Enter</i> buttons to display the unit's system information, and set its ID.
14	power LED	Lights green when the unit is turned on.

Rear Panel

VK1100A

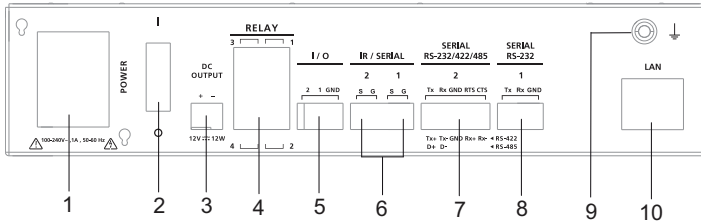

VK1200

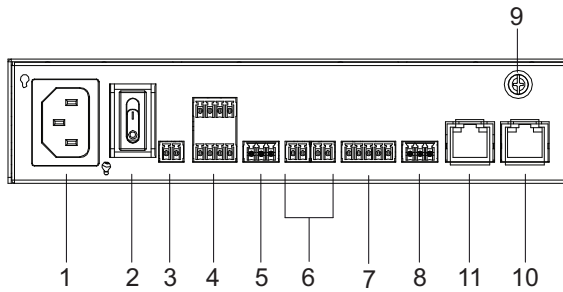

VK2100A

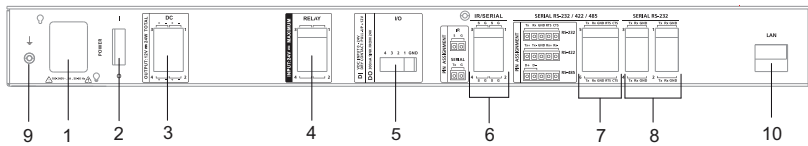

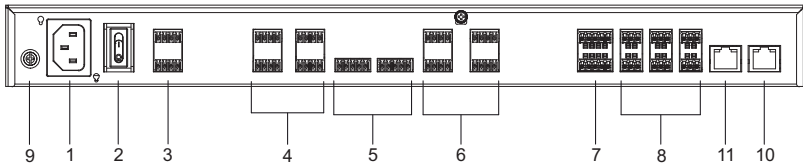
VK2200

No.	Component	Description
1	power socket	Plugs in the power cord from an AC power source.
2	power switch	Powers the unit on or off.
3	12 V DC output ports	1 / 4 DC output port(s) providing a total output of 12 V DC, 1 / 2 A from the Control Box.
4	relay channels	4 / 8 channels; normally open, isolated relays with a contact rating of 24 V DC, 2 A max.
5	I/O channels	2 / 4 / 8 channels that can be configured as digital inputs or outputs, with the first pin being ground and the rest being number pins. ◆ Digital Input: <ul style="list-style-type: none"> ◆ VDC Mode: 0 - 24 V DC; programmable range of 1 - 24 V DC ◆ Dry Contact Mode: Pull-up 2k Ω to +12 V DC ◆ Digital Output: 300 mA sink from 24 V DC
6	IR / serial ports	2 / 4 / 8 IR ports that can also be configured as RS-232 TX ports. pin 1: Signal / pin 2: Ground.
7	RS-232/422/485 serial ports	1 / 2 5-pin RS-232/422/485 serial ports by pin assignment.
8	RS-232 serial ports	1 / 4 / 6 3-pin RS-232 serial ports with Tx, Rx and GND.
9	grounding terminal	Connects to the grounding wire.

No.	Component	Description	
10	LAN	Connects the unit to the corporate LAN for remote access and centralized management by ATEN Unizon.	Default network settings when no dynamic IP address is assigned, by a DHCP server, after 30 seconds: IP: 192.168.1.60 / mask: 255.255.255.0
11	Control LAN	Connects the unit to a secure subnetwork, separate from the corporate LAN, for managing IP devices and configuration by the ATEN Configurator VK6000, as well as for remote control by ATEN Keypads, Touch Panel or the ATEN Control System app on mobile devices.	Default network settings when no dynamic IP address is assigned, by a DHCP server, after 30 seconds: IP: 192.168.0.60 / mask: 255.255.255.0

Overall Installation Procedure

The installation of the Control Box Gen. 2 shall be done in the following order:

- ◆ **Step 1 — Mounting the Control Box**
see *Placement*, page 11.
- ◆ **Step 2 — Powering the Control Box**
see *Powering the Control Box*, page 16.
- ◆ **Step 3 — ID Setting and Initialization**
see *ID, Network & License Configuration*, page 17.
- ◆ **Step 4 — Wiring and Connecting Devices**
see *Wiring and Connecting to Devices*, page 22.
- ◆ **Step 5 — Adding the Control Box on VK6000**
see *ATEN Configurator — VK6000*, page 35.

Chapter 2 Getting Started

Placement

Rack Mount

The Control Box can be mounted onto a 19" (1U) system rack. To install your Control Box, follow the corresponding procedure below for your specific model.

■ *VK2100A / VK2200*

■ *VK1100A / VK1200*

VK2100A / VK2200

1. Using the supplied rack mount kit, attach the 2 mounting brackets onto the sides of the unit with the 6 screws (M3x6) included.

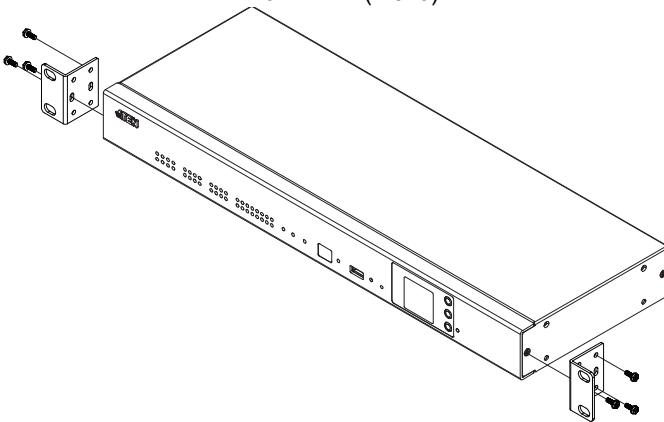

2. Align the mounting brackets' screw holes with that of the front of the rack, and secure the unit onto the rack using 4 self-supplied screws.

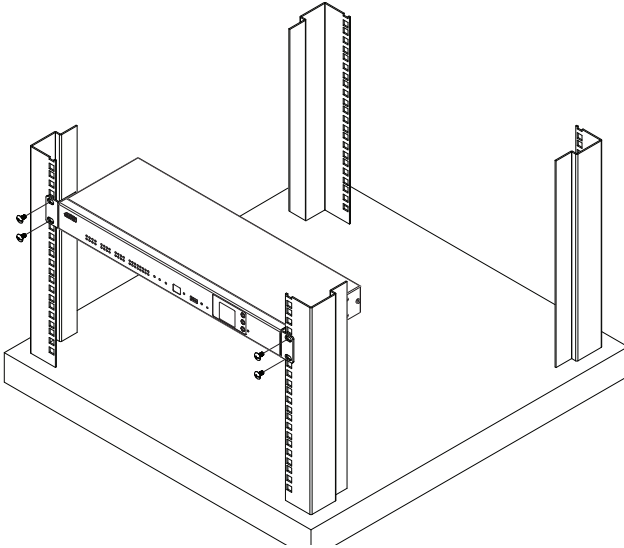

VK1100A / VK1200

The VK1100A / VK1200 can be mounted with the Single Rack Mount kit (2X-049G) or the Dual Rack Mount kit (2X-021G).

Note: For VK1100A / VK1200, the rack mount kit (2X-021G / 2X-049G) must be purchased separately.

■ Single Rack Mount (2X-049G)

1. Using the rack mount kit, attach the 2 mounting brackets onto the sides of the unit with the 4 screws (M3x6) included.

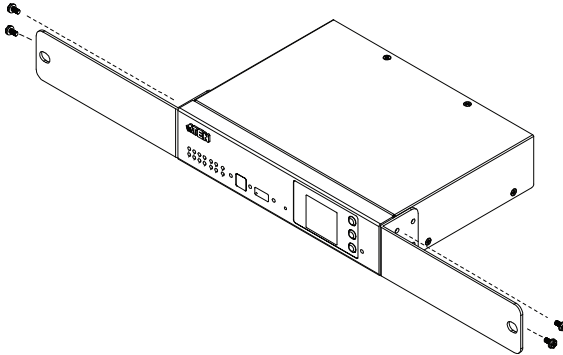

2. Align the mounting brackets' screw holes with that of the front of the rack, and secure the unit onto the rack using 2 self-supplied screws.

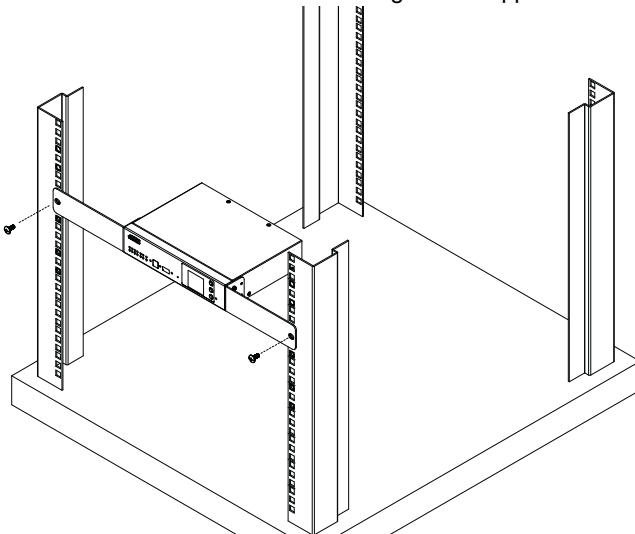

■ Dual Rack Mount (2X-021G)

1. Remove 2 screws at the bottom and 1 screw at the side from each of the two VK1100A / VK1200 units, as shown below.

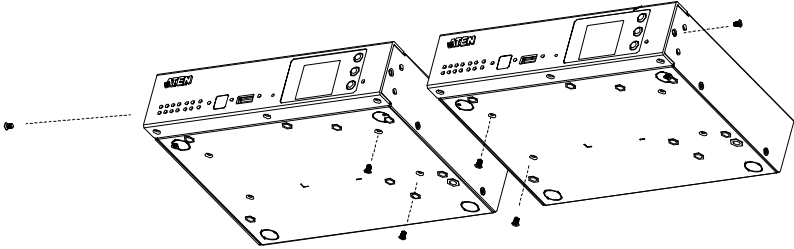

2. Use 4 of the screws from step 2 to secure the two VK1100A / VK1200 units together with the link bracket. Then install the left and right mounting brackets onto the sides of the units using 2 of the M3x5 and M3x6 screws included.

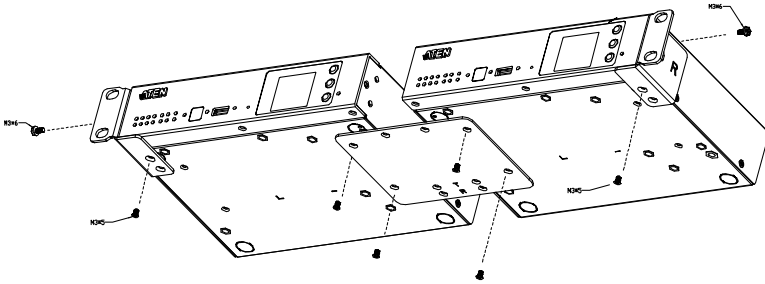

3. Align the mounting brackets' screw holes with that of the front of the rack, and secure the units onto the rack using 4 self-supplied screw.

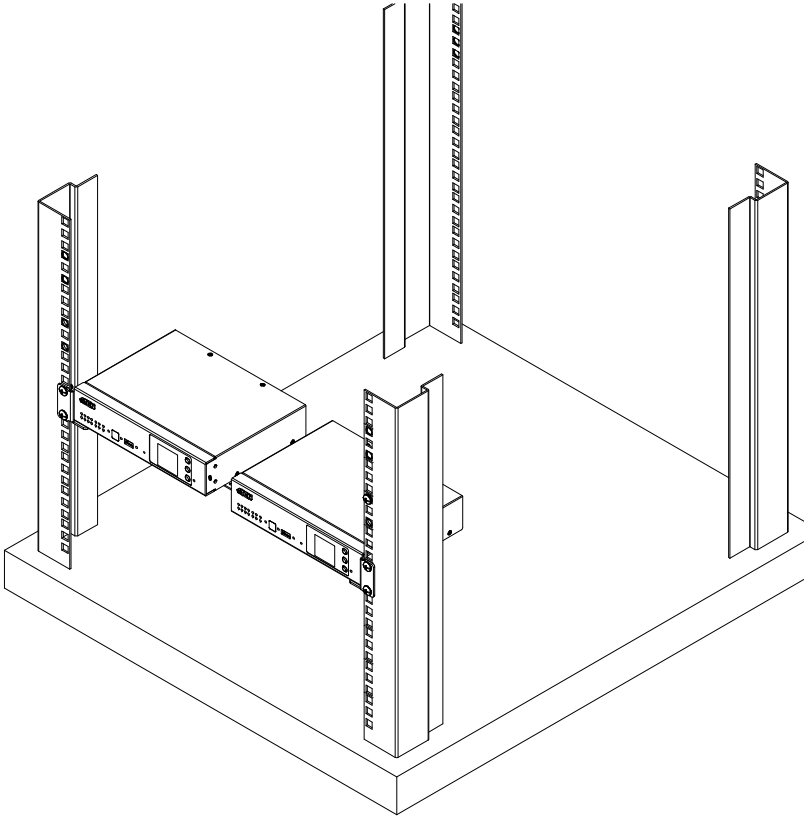

Desktop

To place the Control Box on a flat surface, such as a desk, simply attach the foot pad set provided onto its 4 corners and place it on the surface.

Powering the Control Box

1. Use a grounding wire to ground the unit by connecting one end to the grounding terminal (No. 9, *Rear Panel*, page 7) and the other end to a suitable grounded object.

Note: Do not omit this step. Proper grounding helps prevent damage to the unit from power surges and static electricity.

2. Plug the power cord into the unit's power socket (No. 1, *Rear Panel*, page 7), and connect it to an AC power source.
3. Using a self-supplied Cat 5e/6 cable, connect the unit to a secured subnetwork via:
 - ◆ Control LAN port for VK1200 / VK2200 (No. 11, *Rear Panel*, page 7)
 - ◆ LAN port for VK1100A / VK2100A (No. 10, *Rear Panel*, page 7)
4. (Optional) For VK1200 / 2200, use another Cat 5e/6 cable to connect the unit to the corporate LAN, via its LAN port (No. 10, *Rear Panel*, page 7), for remote access and/or centralized management by ATEN Unizon.
5. Start the unit by switching on its power switch (No. 2, *Rear Panel*, page 7). Upon startup, all of the Control Box's interface LEDs will blink once, with the buzzer beeping once.

Chapter 3 Initialization

ID, Network & License Configuration

Setting Control Box ID

- ◆ For VK1200 / VK2200, use the LCD panel on the front panel to set its ID.
- ◆ For VK1100A / VK2100A, use the Control Box ID switch to set its ID.

Note: Take note of the control box ID, which should be unique and unrepeatable if there are other controllers within the same subnet.

Determining the IP Address

	VK1100A / VK2100A	VK1200 / VK2200
DHCP	When connected to a DHCP network, the control box is assigned with an IP address automatically upon startup.	
Non-DHCP	When no dynamic IP address is assigned to it within 30 seconds after startup, the control box's default network settings are applied:	
	LAN Default IP Address: 192.168.0.60 Subnet Mask: 255.255.255.0	LAN Default IP Address: 192.168.1.60 Subnet Mask: 255.255.255.0 Control LAN (CLAN) Default IP Address: 192.168.0.60 Subnet Mask: 255.255.255.0

The network information of the VK1200 / VK2200 can be found on its LCD panel, via *Information*, as illustrated below.



The network information of the VK1100A / VK2100A can be determined using the IP Installer. Follow the steps below to install IP Installer.

1. Using a Windows PC, download the **IP Installer** zip file in *Support and Downloads* from the ATEN controller's product web page.
2. Extract and execute **IPInstaller.exe**. A window similar to the one below appears.

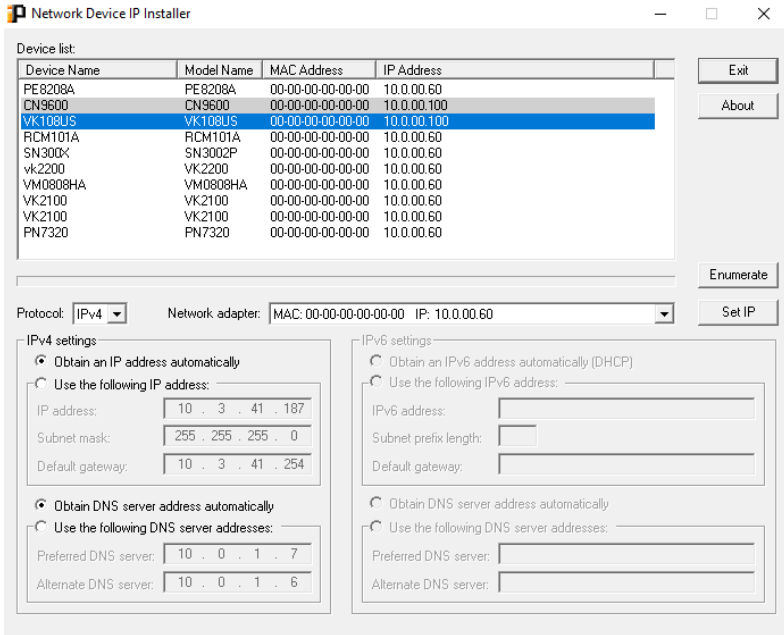

3. Make sure the proper network adapter is selected and click **Enumerate** to search for and display your ATEN controllers within the *Device List*.

Changing Network Settings

There are two methods of changing the network settings of the Control Box — via **IP Installer** or **web interface** — on a PC within the same subnet.

IP Installer

1. Using a Windows PC, download **IP Installer** zip file under *Support and Downloads* from the Control Box's product web page. Then extract and execute *IPInstaller.exe*.
2. Select the Control Box model from the *Device List*, and select **Use the following IP address** under *IPv4 settings* to change its IP address, subnet mask, and default gateway.

Web Interface

◆ Accessing the Web Interface

1. Open a web browser, enter the Control Box's IP address, and log into its web interface using the default access key — *password*. Upon login, the user will be prompted and required to set a new password for the unit.
2. Click **Settings**  > **Network**, select **Manually (DHCP off)** from the *Get IP Address* drop-down list, and change its network settings, namely IP address, subnet mask, and default gateway.

◆ Working as a DHCP Server

To set the VK1200 / VK2200 as a DHCP server for automatically assigning dynamic IP addresses to the IP devices managed via its Control LAN, do the following:

Control LAN	
Get IP Address	Enable DHCP Server ▾
IP Address	10.3.41.149
Subnet Mask	255.255.255.0
Default Gateway	10.3.41.254
IP Assigned Range	192.168.0.61 - 192.168.0.254
Lease Time (sec.)	7200

1. From the *Get IP Address* drop-down list, select **Enable DHCP Server**, and optionally change the network settings of the VK1200 / VK2200, namely IP address, subnet mask, and default gateway.
2. Next to **IP Assigned Range**, define the desired range of IP that can be used for assigning IP addresses to the connecting IP devices.
3. Next to **Lease Time**, define the amount of time an assigned IP address becomes available for use after the IP device it is previously assigned to has been inactive for.

Firmware

The current firmware version of the Control Box is displayed on its web interface main page, as shown below.

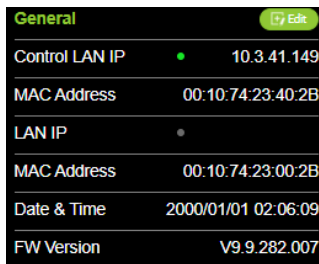

General Edit	
Control LAN IP	10.3.41.149
MAC Address	00:10:74:23:40:2B
LAN IP	
MAC Address	00:10:74:23:00:2B
Date & Time	2000/01/01 02:06:09
FW Version	V9.9.282.007

Upgrading Firmware

To upgrade the Control Box's firmware, download the latest firmware file from its product web page, and save it on the PC.

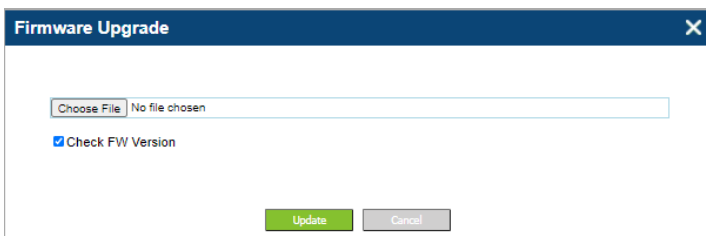

On the Control Box's web interface main page, click **Edit** next to *General*, and click **Update** under *Firmware*. Then browse for the downloaded firmware file to upgrade.

Note: When **Check FW Version** is checked, the unit will compare its current firmware version with that of the firmware file selected, and only allow upgrading to a later version.

Licenses

A license is a software permit that a Control Box grants to a mobile device for remote control. The Control Box's numbers of free and maximum licenses are described below:

License	VK1100A / VK2100A	VK1200 / VK2200
Free Licenses	2	2
Max. Licenses	16	32

Adding Licenses

By default, the Control Box is supplied with 2 free licenses for granting remote control to 2 mobile devices.

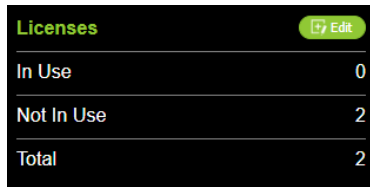

Licenses Edit	
In Use	0
Not In Use	2
Total	2

To add additional licenses, click **Edit** next to *Licenses* on its web interface main page, and click **Add License**. Then follow the on-screen instructions to export a license file, apply for a license upgrade, and import the upgraded license file.

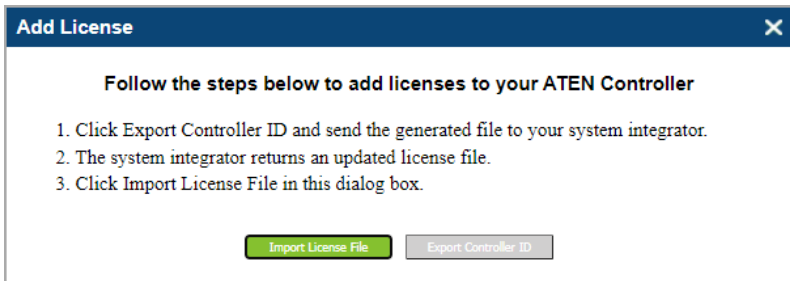

Add License
×

Follow the steps below to add licenses to your ATEN Controller

1. Click Export Controller ID and send the generated file to your system integrator.
2. The system integrator returns an updated license file.
3. Click Import License File in this dialog box.

Import License File
Export Controller ID

Wiring and Connecting to Devices

To connect the Control Box to various devices, for integration and control, refer to the corresponding interface for the wiring information of each.

- ♦ **12 V DC Power Outputs** — see *12 V DC Power Output*, page 22.
- ♦ **Relay** — see *Relay*, page 24.
- ♦ **Digital I/O** — see *Digital I/O*, page 27.
- ♦ **Bidirectional Serial** — see *Bidirectional Serial*, page 31.
- ♦ **Unidirectional IR / Serial** — see *Unidirectional IR / Serial*, page 32.
- ♦ **Control LAN** — see *Control LAN*, page 34.

Note: All diagrams herein are exemplified using VK2200.

12 V DC Power Output

The Control Box Gen. 2 provides the following 12 V DC output(s):

	VK1100A / VK1200	VK2100A / VK2200
Number of Channels	1	4
Max. Power Supply	DC 12 V, 1 A	DC 12 V, 2 A

It can power one or four independent hardware device(s), as illustrated below, as well as relay or digital output devices.

Note: For powering relay or digital output devices connected, please refer to *Powered by 12 V DC Power Output*, page 25, and *Powered by 12 V DC Power Output*, page 29, respectively.

Independent Power Supply

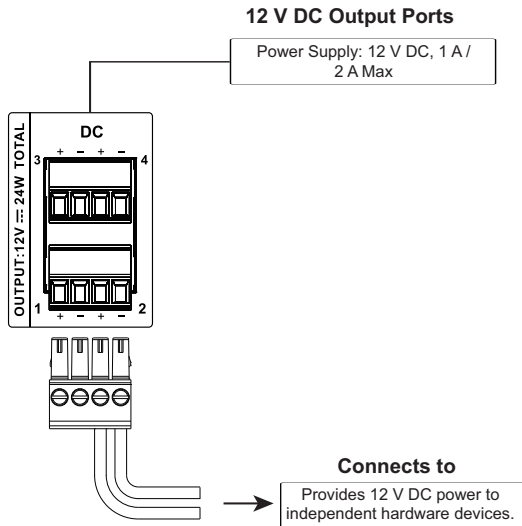

When the total current exceeds the maximum threshold, the DC power overload LED lights orange, and the alarm beeps for 3 seconds, while turning the channel(s) off.

To correct power overload:

1. Turn off the Control Box.
2. Disconnect all devices connected to the 12 V DC outputs.
3. Turn the Control Box back on.
4. Reconnect the devices one at a time, to ensure the maximum current threshold is not exceeded.

Relay

The Control Box Gen. 2 provides the following isolated relays:

	VK1100A / VK1200 / VK2100A	VK2200
Number of Channels	4	8
Contact Rating	24 V DC, 2 A	
Default Status	Normally Open	

Using Self-Supplied Power

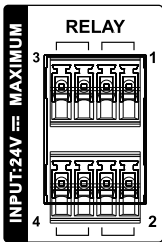

Relay Channels

- All are normally open, isolated relays.
- Contact Rating: 24 V DC 2 A Max

Normally Open Closed

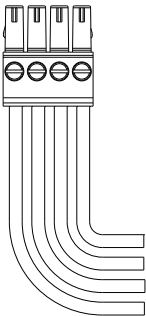

Connects to room control equipment

- For example, you may connect the relay channels to external relays, or devices equipped with relay channels, such as switch, screen, projector lift, lighting, motorized equipment, motion device, etc.
- Do not exceed a total of 24V DC, 2A for each channel.

Powered by 12 V DC Power Output

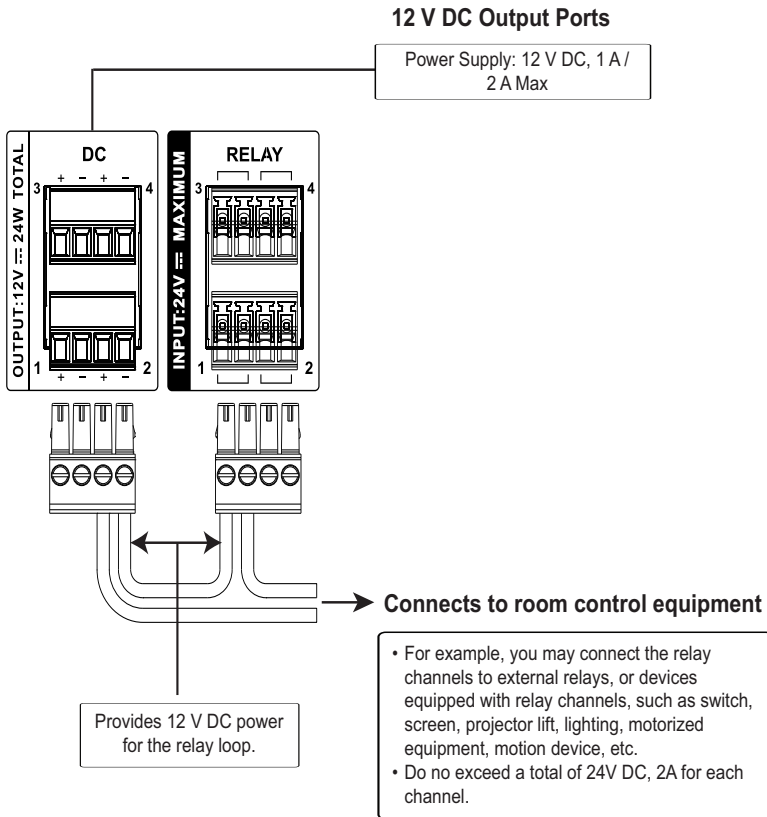

Application: Control Using External Relays

To install external relays, refer to the illustration below where two external relays are used to control a projector screen.

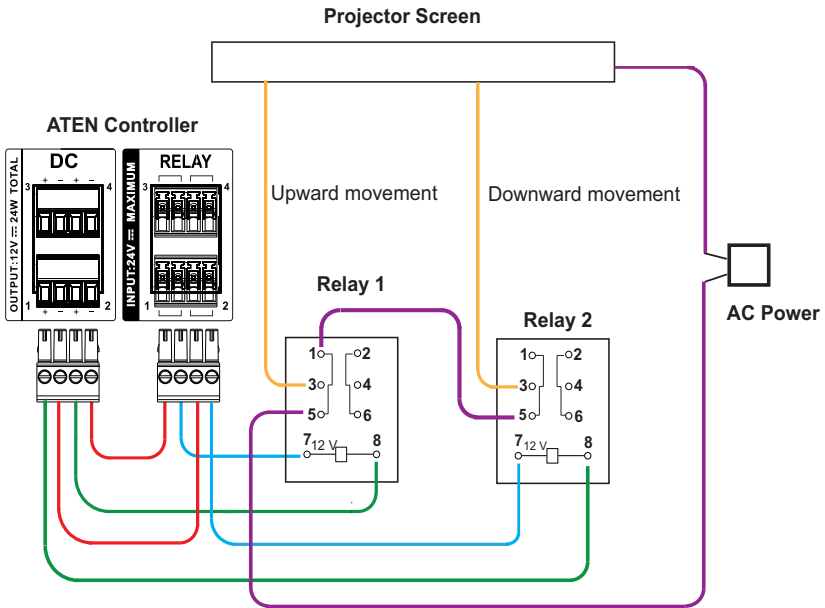

Relay Pins Definition

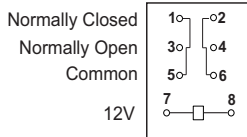

Digital I/O

The Control Box Gen. 2 provides the following digital input/output channels:

		VK1100A / VK1200	VK2100A	VK2200
Number of Channels		2	4	8
Digital Input	VDC Mode	Voltage range: 0 ~ 24 V DC Programmable range: 1 ~ 24 V DC		
	Dry Contact Mode	Pull-up: 2 k Ω to +12 V DC		
Digital Output		Normally Open 300 mA sink from 24 V DC		

Digital Input

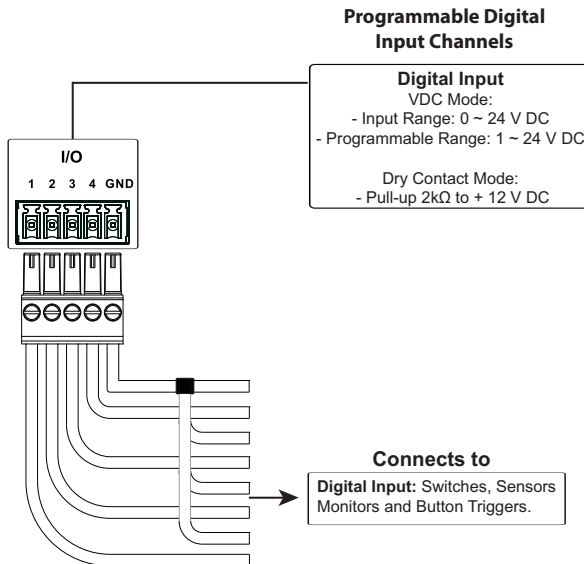

■ Dry Contact

Connects to digital I/O devices with an input loop — open or closed — for providing indicators from sensors or switches of an event, which can be used by the Control Box to trigger certain events and/or functions.

■ VDC Mode

Connects to DC devices for providing voltage signals (1 ~ 24 V) to the Control Box, to trigger certain events and/or functions when the voltage signals are above *or* below the defined threshold.

Digital Output

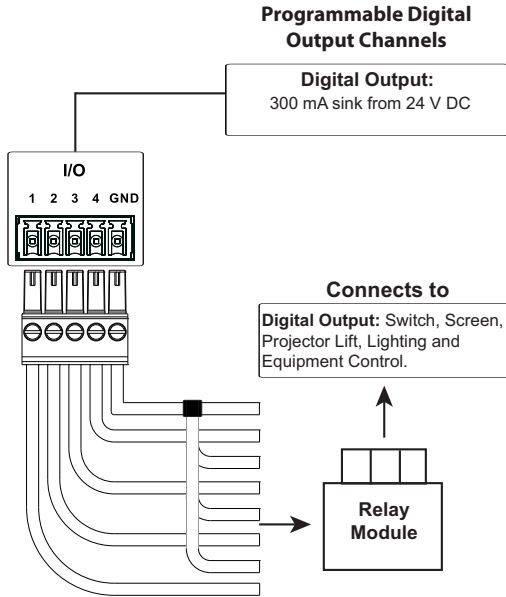

Digital outputs provide non-powered dry contact (open and closed) circuit control of devices, which must be connected using a **relay module**.

■ Powered by 12 V DC Power Output

12 V DC Output Ports

Power Supply: 12 V DC, 1 A /
2 A Max

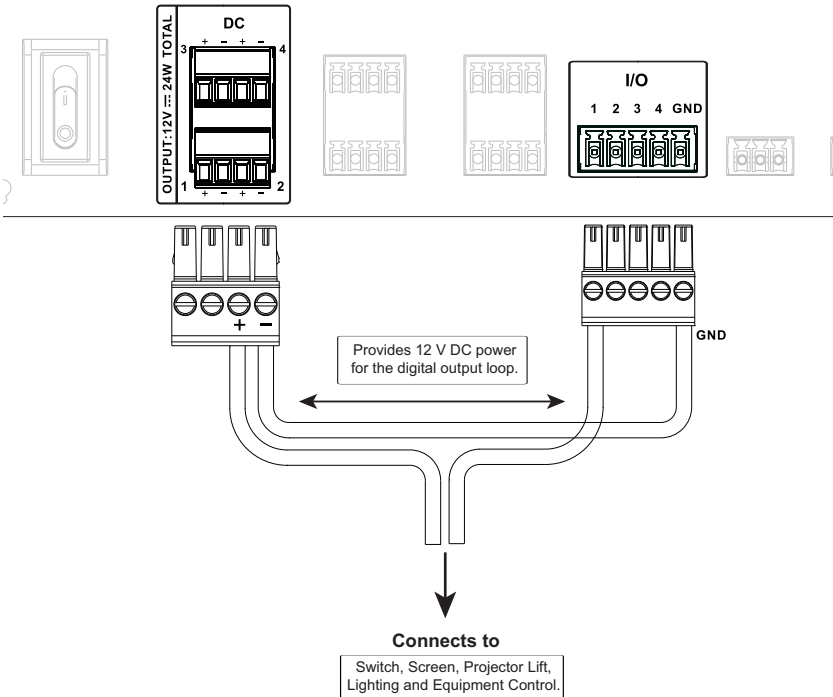

■ Digital Output Dual Power Supply

12 V DC Output Ports

Power Supply: 12 V DC, 1 A /
2 A Max

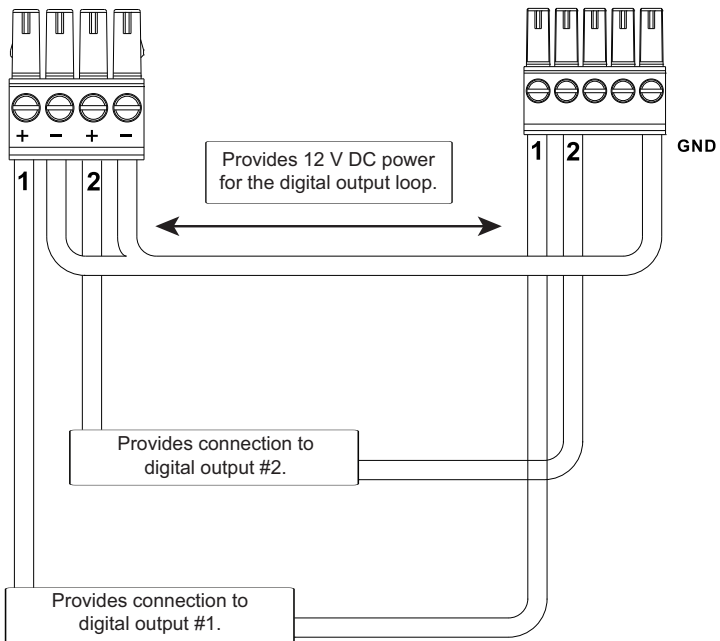
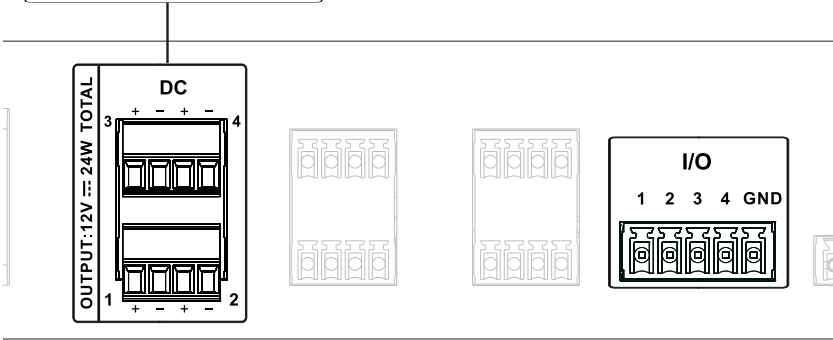

Bidirectional Serial

The Control Box Gen. 2 provides the following RS-232/422/485 ports:

		VK1100A / VK1200	VK2100A	VK2200
Number of Channels	3-Pin RS-232	1	4	6
	5-Pin RS-232/422/485	1	2	2
Baud rate		300 ~ 115200 (default: 9600)		
Data bit		7, 8 (default)		
Stop bit		1 (default), 2		
Parity		None (default), Even, Odd		

RS-232 (3-Pin)

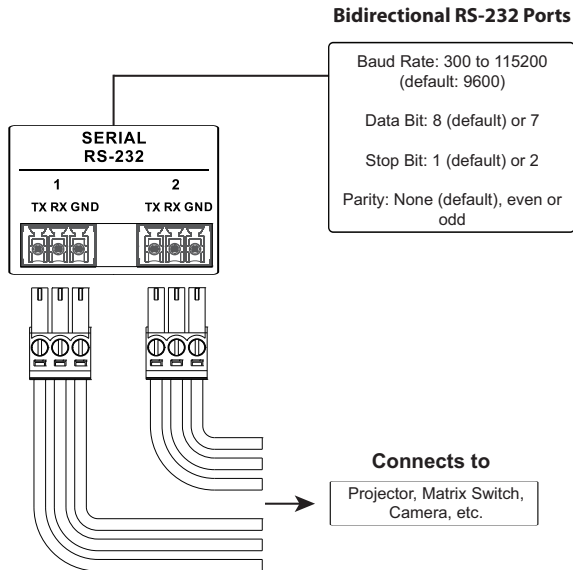

Connect to devices for controlling and receiving status messages from them. For bi-directional RS-232 control, the transmit (TX), receive (RX) and ground (GND) terminals must be wired on both the Control Box and the device connecting.

RS-232/422/485 (5-Pin)

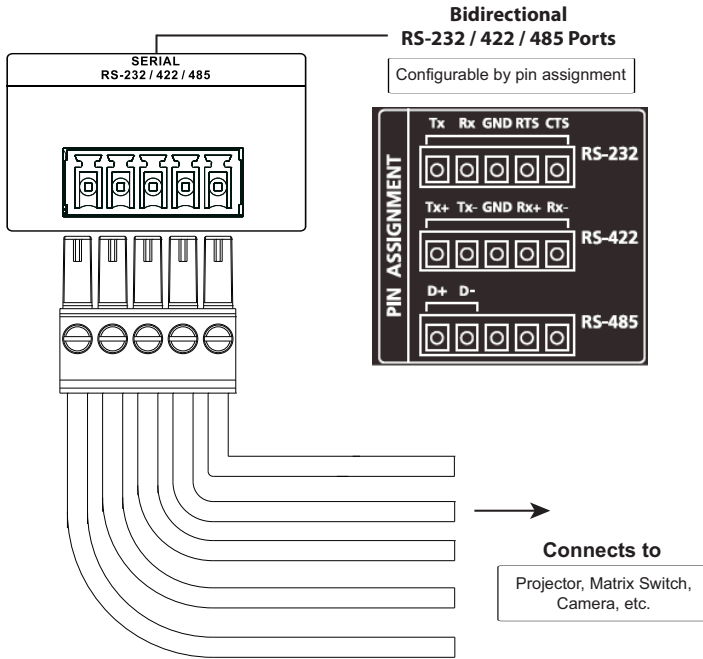

Connect to devices, configurable by pin assignments, for controlling and receiving status messages from them.

Unidirectional IR / Serial

The Control Box Gen. 2 provides the following IR / serial (RS-232) ports:

		VK1100A / VK1200	VK2100A	VK2200
2-Pin IR/Serial		2	4	8
IR	Carrier Frequency	10 ~ 455 kHz		
	Default Level	Low		
Serial (RS-232)	Baud rate	300 ~ 115200 (default: 9600)		
	Data bit	7, 8 (default)		
	Stop bit	1 (default), 2		
	Parity	None (default), Even, Odd		
	Signal Level	TTL (0 ~ 5 V DC)		

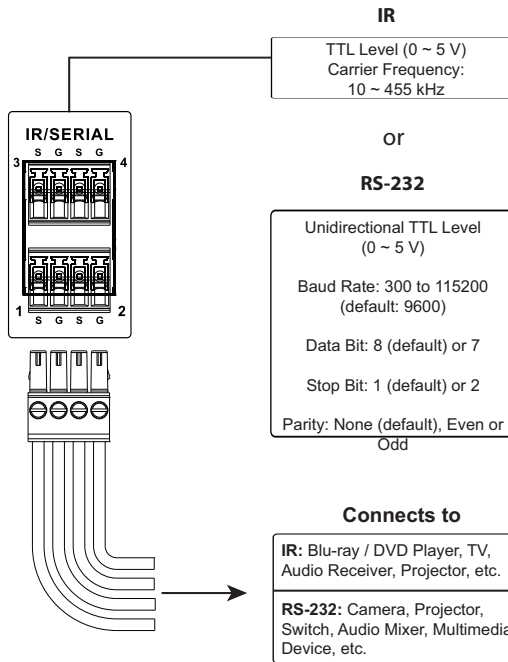

Connect to IR and/or RS-232 devices. By default, these channels are set to transmit IR signals.

IR Connection

Connect a transmitter cable to a set of IR and ground terminals of the Control Box, and set up the IR transmitter on or near the IR receiving port of the IR device.

Serial Connection

Connect a serial device's receiver (RX) and ground (GND) terminals to a set of serial (TX) and ground (GND) terminals of the Control Box.

Control LAN

The LAN (VK1100A / VK2100A) or Control LAN (VK1200 / VK2200) port provides an Ethernet connection for controlling up to 25 (VK1100A / VK2100A) or 64 (VK1200 / VK2200) IP devices and/or remote control by ATEN Keypads, Touch Panel, and the ATEN Control System app on a mobile device within the same subnetwork.

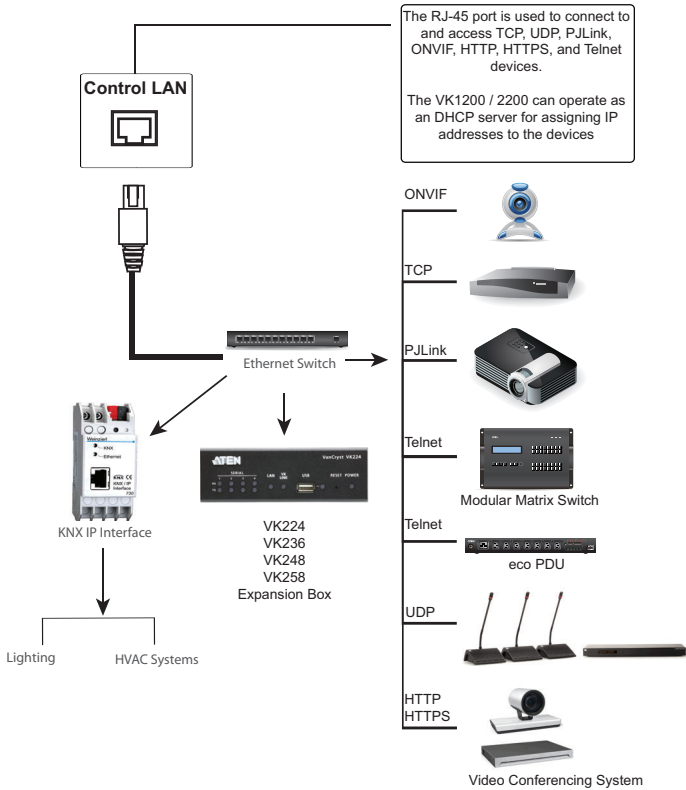

Chapter 5

Configuring a Profile

ATEN Configurator — VK6000

Download the ATEN Configurator software — VK6000 — from its product web page, and install it on a PC.

Adding the Control Box

1. After installing the ATEN Configurator, the main page appears. start by clicking the **Project** tab at the top.



2. On the **Project** tab, provide the information of the Control Box. Then click **Start Project**.
3. In the **Device** tab, add all devices to be managed by the Control Box into the *Device Configuration* list.

Once all devices are successfully added and configured by the VK6000, users can start designing dedicated control interfaces — **Viewers** — on the VK6000 to be uploaded into the Control Box for easy remote control to all devices via ATEN Keypads, Touch Panel, or Control System app with mobile devices.

For detailed information on VK6000, as well as Control System mobile app, please refer to the *Control System User Manual*.

ATEN Expansion Box

For adding additional ports, users can purchase the ATEN Expansion Boxes to be connected to the Control Box for flexible scalability, including:

Model	Description
VK224	4-Port Bidirectional Serial Expansion
VK236	6-Port Unidirectional IR/Serial Expansion Box
VK248	8-Channel Relay Expansion Box
VK258	8-Channel Digital I/O Expansion Box

Safety Instructions

General

- ◆ This product is for indoor use only.
- ◆ Read all of these instructions. Save them for future reference.
- ◆ Follow all warnings and instructions marked on the device.
- ◆ Do not place the device on any unstable surface (cart, stand, table, etc.). If the device falls, serious damage will result.
- ◆ Do not use the device near water.
- ◆ Do not place the device near, or over, radiators or heat registers.
- ◆ The device cabinet is provided with slots and openings to allow for adequate ventilation. To ensure reliable operation, and to protect against overheating, these openings must never be blocked or covered.
- ◆ The device should never be placed on a soft surface (bed, sofa, rug, etc.) as this will block its ventilation openings. Likewise, the device should not be placed in a built in enclosure unless adequate ventilation has been provided.
- ◆ Never spill liquid of any kind on the device.
- ◆ Unplug the device from the wall outlet before cleaning. Do not use liquid or aerosol cleaners. Use a damp cloth for cleaning.
- ◆ Avoid circuit overloads. Before connecting equipment to a circuit, know the power supply's limit and never exceed it. Always review the electrical specifications of a circuit to ensure that you are not creating a dangerous condition or that one doesn't already exist. Circuit overloads can cause a fire and destroy equipment.
- ◆ The device should be operated from the type of power source indicated on the marking label. If you are not sure of the type of power available, consult your dealer or local power company.
- ◆ The device is designed for IT power distribution systems with 230V phase-to-phase voltage.
- ◆ To prevent damage to your installation, it is important that all devices are properly grounded.
- ◆ The device is equipped with a 3-wire grounding type plug. This is a safety feature. If you are unable to insert the plug into the outlet, contact your

electrician to replace your obsolete outlet. Do not attempt to defeat the purpose of the grounding-type plug. Always follow your local/national wiring codes.

- ◆ Do not allow anything to rest on the power cord or cables. Route the power cord and cables so that they cannot be stepped on or tripped over.
- ◆ If an extension cord is used with this device make sure that the total of the ampere ratings of all products used on this cord does not exceed the extension cord ampere rating. Make sure that the total of all products plugged into the wall outlet does not exceed 15 amperes.
- ◆ To help protect your system from sudden, transient increases and decreases in electrical power, use a surge suppressor, line conditioner, or un-interruptible power supply (UPS).
- ◆ Position system cables and power cables carefully; Be sure that nothing rests on any cables.
- ◆ Never push objects of any kind into or through cabinet slots. They may touch dangerous voltage points or short out parts resulting in a risk of fire or electrical shock.
- ◆ Do not attempt to service the device yourself. Refer all servicing to qualified service personnel.
- ◆ If the following conditions occur, unplug the device from the wall outlet and bring it to qualified service personnel for repair.
 - ◆ The power cord or plug has become damaged or frayed.
 - ◆ Liquid has been spilled into the device.
 - ◆ The device has been exposed to rain or water.
 - ◆ The device has been dropped, or the cabinet has been damaged.
 - ◆ The device exhibits a distinct change in performance, indicating a need for service.
 - ◆ The device does not operate normally when the operating instructions are followed.
- ◆ Only adjust those controls that are covered in the operating instructions. Improper adjustment of other controls may result in damage that will require extensive work by a qualified technician to repair.
- ◆ Do not connect the RJ-11 connector marked “UPGRADE” to a public telecommunication network.

Rack Mounting

- ◆ Before working on the rack, make sure that the stabilizers are secured to the rack, extended to the floor, and that the full weight of the rack rests on the floor. Install front and side stabilizers on a single rack or front stabilizers for joined multiple racks before working on the rack.
- ◆ Always load the rack from the bottom up, and load the heaviest item in the rack first.
- ◆ Make sure that the rack is level and stable before extending a device from the rack.
- ◆ Use caution when pressing the device rail release latches and sliding a device into or out of a rack; the slide rails can pinch your fingers.
- ◆ After a device is inserted into the rack, carefully extend the rail into a locking position, and then slide the device into the rack.
- ◆ Do not overload the AC supply branch circuit that provides power to the rack. The total rack load should not exceed 80 percent of the branch circuit rating.
- ◆ Make sure that all equipment used on the rack – including power strips and other electrical connectors – is properly grounded.
- ◆ Ensure that proper airflow is provided to devices in the rack.
- ◆ Ensure that the operating ambient temperature of the rack environment does not exceed the maximum ambient temperature specified for the equipment by the manufacturer
- ◆ Do not step on or stand on any device when servicing other devices in a rack.
- ◆ **Caution:** Slide/rail (LCD KVM) mounted equipment is not to be used as a shelf or a work space.
- ◆ A multi position slide rail shall not extend automatically to any of the extended positions. The SRME shall only be able to go to the service position when pulled out. A latch or other means shall be provided to stop the SRME in the service position. Any service position and installation position shall be explained. An **instructional safeguard** shall be provided for the installer. The elements of the **instructional safeguard** shall be as follows:
 - element 2: Stability hazard
 - element 3: “The rack may tip over causing serious personal injury”
 - element 4: the text below or equivalent text



Technical Support

International

- ◆ For online technical support – including troubleshooting, documentation, and software updates: <http://eservice.aten.com>
- ◆ For telephone support, *Telephone Support*, page iv.

North America

Email Support		support@aten-usa.com
Online Technical Support	Troubleshooting Documentation Software Updates	http://www.aten-usa.com/support
Telephone Support		1-888-999-ATEN ext 4988

When you contact us, please have the following information ready beforehand:

- ◆ Product model number, serial number, and date of purchase.
- ◆ Your computer configuration, including operating system, revision level, expansion cards, and software.
- ◆ Any error messages displayed at the time the error occurred.
- ◆ The sequence of operations that led up to the error.
- ◆ Any other information you feel may be of help.

Specifications

VK1100A	
Memory	
SDRAM	512 MB
Flash	8 GB
Interfaces	
Serial	<p>1 x Programmable bidirectional RS-232/422/485 port (1 x 5-pole terminal block connector, configurable via pin assignments)</p> <ul style="list-style-type: none"> ◆ Baud Rate: 300 to 115200 (default: 9600) ◆ Data Bit: 8 (default) or 7 ◆ Stop Bit: 1 (default) or 2 ◆ Parity: None (default), Even, or Odd ◆ Flow Control: None (default) or RTS/CTS <p>1 x bidirectional RS-232 port (1 x 3-pole terminal block connector)</p> <ul style="list-style-type: none"> ◆ Baud Rate: 300 ~ 115200 (default: 9600) ◆ Data Bit: 8 (default) or 7 ◆ Stop Bit: 1 (default) or 2 ◆ Parity: None (default), Even, or Odd
IR/Serial	<p>2 x Programmable IR / Unidirectional RS-232 Ports (2 x 2-Pole Terminal Block Connectors)</p> <hr/> <p>IR:</p> <ul style="list-style-type: none"> ◆ Carrier Frequency: 10 ~ 455 kHz ◆ Signal Level: TTL (0 ~ 5 V DC) <hr/> <p>Serial:</p> <ul style="list-style-type: none"> ◆ Baud Rate: 300 ~ 115200 (default: 9600) ◆ Data Bit: 8 (default) or 7 ◆ Stop Bit: 1 (default) or 2 ◆ Parity: None (default), Even, or Odd ◆ Signal Level: TTL (0 ~ 5 V DC)

VK1100A	
I/O	<p>2 x Programmable Digital Input / Output Channels (1 x 3-Pole Terminal Block Connector)</p> <p>Digital Output: 300 mA sink from 24 V DC</p> <p>Digital Input:</p> <p>VDC Mode</p> <ul style="list-style-type: none"> ◆ Input Voltage Range: 0 ~ 24 V DC ◆ Programmable Range: 1 ~ 24 V DC <p>Dry Contact Mode</p> <ul style="list-style-type: none"> ◆ Pull-up 2 kΩ to +12 V DC
Relay	<ul style="list-style-type: none"> ◆ 4 x Relay Channels (2 x 4-Pole Terminal Block Connector) ◆ Normally Open, Isolated Relays ◆ Contact Rating: Max 24 V DC, 2 A
V DC	<ul style="list-style-type: none"> ◆ 1 x 12 V DC Output Port (1 x 2-Pole Terminal Block Connector) ◆ Power Supply: 12 V DC, 1 A Max
Ethernet	<ul style="list-style-type: none"> ◆ 2 x RJ-45 Female, 10/100/1000 Base-T ◆ Supported protocol: ARP, ICMP, TCP/IP, DHCP, HTTPS, SSH ◆ DHCP-enabled: If no IP address is assigned to the unit within 30 seconds of connecting to the network, the following default IP settings will be applied. <ul style="list-style-type: none"> ◆ Control LAN / LAN IP address: 192.168.0.60 / 192.168.1.60 ◆ Subnet Mask: 255.255.255.0
USB	1 x USB Type-A
Switches	
Power	1 x on/off Switch
IR Learning	
1 x IR Receiver LED	
Reset Button	
1 x Semi-recessed pushbutton	

VK1100A**Power**

Maximum Input Power Rating	100 - 240 V AC, 50 - 60 Hz, 1 A
Power Consumption	AC 110 V : 4.3 W : 82 BTU/h AC 220 V : 4.5 W : 83 BTU/h

Note:

- ◆ The measurement in Watts indicates the typical power consumption of the device with no external loading.
- ◆ The measurement in BTU/h indicates the power consumption of the device when it is fully loaded.

Environmental

Operating Temperature	0 – 50 °C
Storage Temperature	-20 – 60 °C
Humidity	0 – 80% RH, Non-condensing

Physical Properties

Housing	Metal
Weight	1.19 kg
Dimensions (L x W x H)	21.50 x 16.23 x 4.18 cm

Mobile Control License

No. of free licenses	2
Max. no. of licenses	16

Note: The ATEN Control Box Gen. 2 comes with two free licenses which are stored in the device itself. Each time a mobile device connects to an ATEN Control Box Gen. 2 for remote control, one license on the Control Box Gen. 2 will be occupied. To purchase and add additional licenses to your Control Box, contact your local sales representative for more information.

VK1200**System**

SD RAM 1 GB

Flash Memory 8 GB

Interface

Serial	<p>1 x Programmable bidirectional RS-232/422/485 port (1 x 5-pole terminal block connector)</p> <p>1 x Programmable bidirectional RS-232 port (1 x 3-pole terminal block connector)</p> <ul style="list-style-type: none"> ◆ Baud Rate: 300 ~ 115200 (default: 9600) ◆ Data Bit: 8 (default) or 7 ◆ Stop Bit: 1 (default) or 2 ◆ Parity: None (default), Even, or Odd ◆ Flow Control: None (default) RTS/CTS (for 5-pole terminal block)
IR/Serial	<p>2 x Programmable IR / Unidirectional RS-232 Ports (2 x 2-Pole Terminal Block Connectors)</p> <hr/> <p>IR:</p> <ul style="list-style-type: none"> ◆ Carrier Frequency: 10 ~ 455 kHz ◆ Signal Level: TTL (0 ~ 5 V DC) <hr/> <p>Serial:</p> <ul style="list-style-type: none"> ◆ Baud Rate: 300 ~ 115200 (default: 9600) ◆ Data Bit: 8 (default) or 7 ◆ Stop Bit: 1 (default) or 2 ◆ Parity: None (default), Even, or Odd ◆ Signal Level: TTL (0 ~ 5 V DC)

VK1200

I/O	<p>2 x Programmable Digital Input / Output Channels (1 x 3-Pole Terminal Block Connector)</p> <hr/> <p>Digital Output: 300 mA sink from 24 V DC</p> <hr/> <p>Digital Input:</p> <p>VDC Mode</p> <ul style="list-style-type: none"> ◆ Input Voltage Range: 0 ~ 24 V DC ◆ Programmable Range: 1 ~ 24 V DC <p>Dry Contact Mode</p> <ul style="list-style-type: none"> ◆ Pull-up 2 kΩ to +12 V DC
Relay	<ul style="list-style-type: none"> ◆ 4 x Relay Channels (2 x 4-Pole Terminal Block Connector) ◆ Normally Open, Isolated Relays ◆ Contact Rating: Max 24 V DC, 2 A
V DC	<ul style="list-style-type: none"> ◆ 1 x 12 V DC Output Port (1 x 2-Pole Terminal Block Connectors) ◆ Power Supply: 12 V DC, 1 A Max
Ethernet	<ul style="list-style-type: none"> ◆ 2 x RJ-45 Female, 10/100/1000 Base-T ◆ Supported protocol: ARP, ICMP, TCP/IP, DHCP, HTTPS, SSH ◆ DHCP-enabled: If no IP address is assigned to the unit within 30 seconds of connecting to the network, the following default IP settings will be applied. <ul style="list-style-type: none"> ◆ Control LAN / LAN IP address: 192.168.0.60 / 192.168.1.60 ◆ Subnet Mask: 255.255.255.0
USB	1 x USB Type-A
LCD Panel	
Size	1.6"
LCM Display	64 x 128 resolution
LCM Setting	3 x Pushbuttons (Up, Down, Enter)
Switches	
Power	1 x on/off Switch

VK1200**IR Learning**

1 x IR Receiver LED

Reset Button

1 x Semi-recessed pushbutton

Power

Maximum Input Power Rating	100 - 240 V AC, 50 - 60 Hz, 1 A
Power Consumption	AC 110 V : 4.7 W : 81 BTU/h AC 220 V : 4.5 W : 81 BTU/h

Note:

- ◆ The measurement in Watts indicates the typical power consumption of the device with no external loading.
- ◆ The measurement in BTU/h indicates the power consumption of the device when it is fully loaded.

Environmental

Operating Temperature	0 – 50 °C
Storage Temperature	-20 – 60 °C
Humidity	0 – 80% RH, Non-condensing

Physical Properties

Housing	Metal
Weight	1.23 kg
Dimensions (L x W x H)	20.00 x 16.41 x 4.40 cm

Mobile Control License

No. of free licenses	2
Max. no. of licenses	32

Note: The ATEN Control Box comes with two free licenses which are stored in the device itself. Each time a mobile device connects to an ATEN Control Box for remote control, one license on the Control Box will be occupied. To purchase and add additional licenses to your Control Box, contact your local sales representative for more information.

VK2100A**System**

SDRAM	1 GB
Flash Memory	8 GB

Interface

Serial	<p>2 x Programmable Bidirectional RS-232/422/485 Ports (2 x 5-Pole Terminal Block Connectors, configurable via pin assignments)</p> <ul style="list-style-type: none"> ◆ Baud Rate: 300 ~ 115200 (default: 9600) ◆ Data Bit: 8 (default) or 7 ◆ Stop Bit: 1 (default) or 2 ◆ Parity: None (default), Even, or Odd ◆ Flow Control: None (default) or RTS/CTS <p>4 x Bidirectional RS-232 Ports (4 x 3-Pole Terminal Block Connector)</p> <ul style="list-style-type: none"> ◆ Baud Rate: 300 ~ 115200 (default: 9600) ◆ Data Bit: 8 (default) or 7 ◆ Stop Bit: 1 (default) or 2 ◆ Parity: None (default), Even, or Odd
IR/Serial	<p>4 x Programmable IR / Unidirectional RS-232 Ports (2 x 4-Pole Terminal Block Connectors)</p> <p>IR:</p> <ul style="list-style-type: none"> ◆ Carrier Frequency: 10 ~ 455 kHz ◆ Signal Level: TTL (0 ~ 5 V DC) <p>Serial:</p> <ul style="list-style-type: none"> ◆ Baud Rate: 300 ~ 115200 (default: 9600) ◆ Data Bit: 8 (default) or 7 ◆ Stop Bit: 1 (default) or 2 ◆ Parity: None (default), Even, or Odd

VK2100A

I/O	<p>4 x Programmable Digital Input / Output Channels (1 x 5-Pole Terminal Block Connectors)</p> <p>Digital Output: 300 mA sink from 24 V DC</p> <p>Digital Input:</p> <p>VDC Mode</p> <ul style="list-style-type: none"> ◆ Input Voltage Range: 0 ~ 24 V DC ◆ Programmable Range: 1 ~ 24 V DC <p>Dry Contact Mode</p> <ul style="list-style-type: none"> ◆ Pull-up 2 kΩ to +12 V DC
Relay	<ul style="list-style-type: none"> ◆ 4 x Relay Channels (2 x 4-Pole Terminal Block Connector) ◆ Normally Open, Isolated Relays ◆ Contact Rating: Max 24 V DC, 2 A
V DC	<ul style="list-style-type: none"> ◆ 4 x 12 V DC Output Ports (2 x 4-Pole Terminal Block Connectors) ◆ Power Supply: 12 V DC, 2 A Max (Shared By 4 Ports)
Ethernet	<ul style="list-style-type: none"> ◆ 1 x RJ-45 Female, 10/100/1000 Base-T ◆ Supported protocol: ARP, ICMP, TCP/IP, DHCP, HTTPS, SSH ◆ DHCP-enabled: If no IP address is assigned to the unit within 30 seconds of connecting to the network, the following default IP settings will be applied. <ul style="list-style-type: none"> ◆ Control LAN / LAN IP address: 192.168.0.60 / 192.168.1.60 ◆ Subnet Mask: 255.255.255.0
USB	1 x USB Type-A

Switches

Power	1 x on/off switch
-------	-------------------

IR Learning

1 x IR Receiver LED

Reset Button

1 x Semi-recessed pushbutton

VK2100A**Power**

Max. Input Power Rating	100 - 240 V AC, 50 - 60 Hz, 1 A
Power Consumption	AC 110 V : 5.2 W : 137 BTU/h AC 220 V : 6.5 W : 143 BTU/h

Note:

- ◆ The measurement in Watts indicates the typical power consumption of the device with no external loading.
- ◆ The measurement in BTU/h indicates the power consumption of the device when it is fully loaded.

Environmental

Operating Temperature	0 – 50 °C
Storage Temperature	-20 – 60 °C
Humidity	0 – 80% RH, Non-condensing

Physical Properties

Housing	Metal
Weight	2.59 kg (5.7 lb)
Dimensions (L x W x H)	43.24 x 16.32 x 4.40 cm (17.02 x 6.43 x 1.73 in.)

Mobile Control License

No. of free licenses	2
Max. no. of licenses	16

Note: The ATEN Control Box comes with two free licenses which are stored in the device itself. Each time a mobile device connects to an ATEN Control Box for remote control, one license on the Control Box will be occupied. To purchase and add additional licenses to your ATEN Control Box, contact your local sales representative for more information.

VK2200**System**

SDRAM	2 GB
Flash Memory	8 GB

Interface

Serial	<p>2 x Bidirectional RS-232/422/485 Ports (2 x 5-Pole Terminal Block Connectors)</p> <ul style="list-style-type: none"> ◆ Baud Rate: 300 ~ 115200 (default: 9600) ◆ Data Bit: 8 (default) or 7 ◆ Stop Bit: 1 (default) or 2 ◆ Parity: None (default), Even or Odd ◆ Flow Control: None (default) or RTS/CTS <p>6 x Programmable Bidirectional RS-232 Ports (6 x 3-Pole Terminal Block Connector)</p> <ul style="list-style-type: none"> ◆ Baud Rate: 300 ~ 115200 (default: 9600) ◆ Data Bit: 8 (default) or 7 ◆ Stop Bit: 1 (default) or 2 ◆ Parity: None (default), Even or Odd
IR/Serial	<p>8 x Programmable IR / Unidirectional RS-232 Ports (4 x 4-Pole Terminal Block Connectors)</p> <hr/> <p>IR:</p> <ul style="list-style-type: none"> ◆ Carrier Frequency: 10 ~ 455 kHz ◆ Signal Level: TTL (0 ~ 5 V DC) <hr/> <p>Serial:</p> <ul style="list-style-type: none"> ◆ Baud Rate: 300 ~ 115200 (default: 9600) ◆ Data Bit: 8 (default) or 7 ◆ Stop Bit: 1 (default) or 2 ◆ Parity: None (default), Even, or Odd ◆ Signal Level: TTL (0 ~ 5 V DC)

VK2200

I/O	<p>8 x Programmable Digital Input / Output Channels (2 x 5-Pole Terminal Block Connectors)</p> <p>Digital Output: 300 mA sink from 24 V DC</p> <p>Digital Input:</p> <p>VDC Mode</p> <ul style="list-style-type: none"> ◆ Input Voltage Range: 0 ~ 24 V DC ◆ Programmable Range: 1 ~ 24 V DC <p>Dry Contact Mode</p> <ul style="list-style-type: none"> ◆ Pull-up 2 kΩ to +12 V DC
Relay	<ul style="list-style-type: none"> ◆ 8 x Relay Channels (4 x 4-Pole Terminal Block Connector) ◆ Normally Open, Isolated Relays ◆ Contact Rating: Max 24 V DC, 2 A
V DC	<ul style="list-style-type: none"> ◆ 4 x 12 V DC Output Ports (2 x 4-Pole Terminal Block Connectors) ◆ Power Supply: 12 V DC, 2 A Max (Shared By 4 Ports)
Ethernet	<ul style="list-style-type: none"> ◆ 2 x RJ-45 Female, 10/100/1000 Base-T ◆ Supported protocol: ARP, ICMP, TCP/IP, DHCP, HTTPS, SSH ◆ DHCP-enabled. Default IP settings (IP address 192.168.0.60 / 192.168.1.60 for Control LAN / LAN, subnet mask 255.255.255.0) will be automatically applied if no IP address is assigned within 30 seconds of connecting to the network.
USB	1 x USB Type-A
LCD Panel	
Size	1.6"
LCM Display	64 x 128 resolution
LCM Setting	3 x Pushbuttons (Up, Down, Enter)
Switches	
Power	1 x on/off switch

VK2200**IR Learning**

1 x IR Receiver LED

Reset Button

1 x Semi-recessed pushbutton

Power

Max. Input Power Rating	100 - 240 V AC, 50 - 60 Hz, 1 A
-------------------------	---------------------------------

Power Consumption	AC 110 V : 5.7 W : 139 BTU/h AC 220 V : 6.8 W : 144 BTU/h
-------------------	--

Note:

- ◆ The measurement in Watts indicates the typical power consumption of the device with no external loading.
- ◆ The measurement in BTU/h indicates the power consumption of the device when it is fully loaded.

Environmental

Operating Temperature	0 – 50 °C
-----------------------	-----------

Storage Temperature	-20 – 60 °C
---------------------	-------------

Humidity	0 – 80% RH, Non-condensing
----------	----------------------------

Physical Properties

Housing	Metal
---------	-------

Weight	2.62 kg
--------	---------

Dimensions (L x W x H)	43.24 x 16.32 x 4.40 cm
------------------------	-------------------------

Mobile Control License

No. of free licenses	2
----------------------	---

Max. no. of licenses	32
----------------------	----

Note: The ATEN Control Box comes with two free licenses which are stored in the device itself. Each time a mobile device connects to an ATEN Control Box for remote control, one license on the Control Box will be occupied. To purchase and add additional licenses to your ATEN Control Box, contact your local sales representative for more information.

ATEN Warranty Policy

The warranty policy may vary by product category and region of purchase. For details, please visit ATEN's official website, select your purchase counties/regions and then go to the Support Center, or contact your local ATEN sales representative for further assistance.

© Copyright 2025 ATEN® International Co., Ltd.
Released: 2025-05-08

ATEN and the ATEN logo are registered trademarks of ATEN International Co., Ltd. All rights reserved. All other brand names and trademarks are the registered property of their respective owners.