

Why Choose HDBaseT™ 3.0?

Driving Multimedia Distribution with the Leading Fully Uncompressed One-cable Solution on the Market



CONTENTS

1. Introduction

- [What is HDBaseT?](#)

2. Why Should You Choose HDBaseT 3.0?

- [At A Glance: HDBaseT 3.0 Comparison Tables](#)

3. ATEN's HDBaseT 3.0 Solutions

- [True 4K HDMI / USB HDBaseT 3.0 Transceiver \(VE1843\)](#)
- [HDBaseT SF/UTP Cat 6 Cable \(2L-2910\)](#)

4. Conclusion

1. Introduction

The Pro AV market continues to see technological improvements year over year, and in the realm of fully uncompressed multimedia delivery solutions, the latest innovation is HDBaseT Spec 3.0. It's the only fully uncompressed HDMI 2.0 multimedia, and 5Play, solution on the market.

This white paper looks at the features and key differences found in the new HDBaseT 3.0 specification, as well as how ATEN has incorporated this new spec into its first video transceiver that works in conjunction with its town twisted-pair cabling to meet the performance requirements set by the HDBaseT Alliance.

What is HDBaseT?

First we should briefly define what HDBaseT is: HDBaseT is a bit exact pass-through channel for video and audio that does not interfere with the DDC line. As such, it does not terminate HDCP (High-bandwidth Digital Content Protection) and it is transparent for EDID—there is no manipulation over HDBaseT.

HDBaseT allows for 5play technology convergence over a single cable that encompasses AV, Ethernet, USB 2.0, control signals (IR, CEC, RS232), and power over HDBaseT signals. In a sense, HDBaseT is the ultimate standard of digital connectivity over a single cable. HDBaseT specs weren't brought about to just reduce the number of cables, though: they're also meant to extend their range and vastly increase bandwidth.

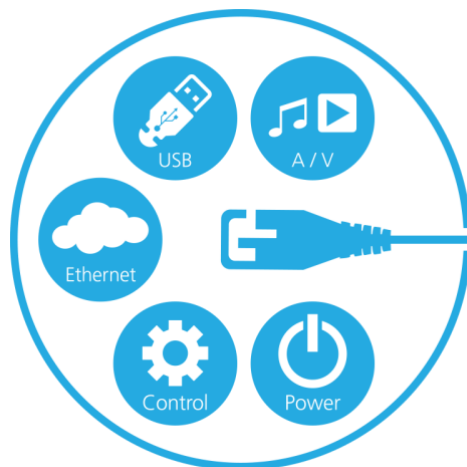

HDBaseT boasts 5Play technology to distribute up to True 4K @ 60Hz 4:4:4 uncompressed AV*, multiple control signals (CEC, RS-232 and IR), USB 2.0, Ethernet and power over a single Cat 6 / 6a cable that reaches 100m, with zero latency.

Why Should You Choose HDBaseT 3.0?

Simply put, HDBaseT Spec 3.0 enables long-distance distribution up to 100m/328ft and of ultra-high speed uncompressed HDMI 2.0 audio & video, independent stereo audio, 1Gb Ethernet, USB 2.0, control, and power, with zero latency, all over one cable.

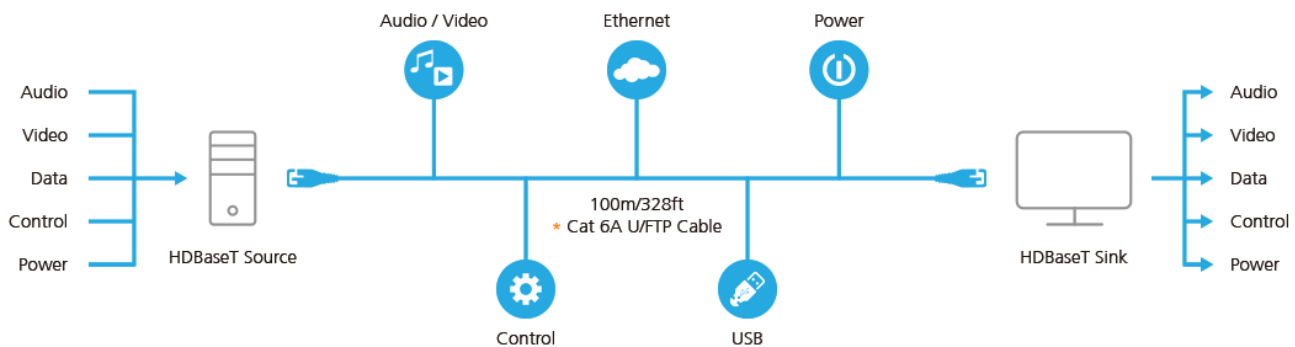

Let's first take a look at long-distance transmission: HDBaseT 1.0 can transmit 1080P signals up to 100m/328ft over Cat 5e, but can only carry 4K 60Hz 4:2:0 signals at a distance of 70m/229ft over Cat 5e. HDBaseT 2.0 raised that bar to deliver 4K 60Hz 4:2:0 signals at a distance of 100m/328ft over Cat 6. Now, HDBaseT spec 3.0 delivers uncompressed 4K 60Hz 4:4:4 signals at a distance of 100m/328ft over Cat 6.

In addition to the above mentioned features, HDBaseT does not interfere with the DDC line, so it won't terminate HDCP (High-Bandwidth Digital Content Protection), and it's transparent when it comes to EDID, as there's no manipulation of it over HDBaseT.

Perhaps most importantly, though, HDBaseT 3.0 also doubles the transmission bandwidth compared to HDBaseT 1.0 and 2.0. For the latter, each twisted pair carries 4-bit modulated "symbols" at a rate of 500M symbols per second, resulting in a Nyquist frequency, or the carrier frequency at half the sample rate, of 250MHz. This matches the bandwidth of Cat 6 cables. HDBaseT 3.0 offers 1G-symbols per second for a frequency of 500MHz, which matches the bandwidth of Cat 6A cables.

HDBaseT can transmit uncompressed HDMI streams in two bandwidth tiers:

- 8 Gbps (equivalent to 10 Gbps in HDMI) w/ HDBaseT specs 1.0 and 2.0
- 16 Gbps (equivalent to 18 Gbps in HDMI) with HDBaseT spec 3.0

In addition to the above mentioned features, HDBaseT 3.0 also has various noteworthy specs in regards to its Ethernet and USB over HDBaseT functionality.

Ethernet

The HDBaseT 3.0 Ethernet definition includes:

- SGMII / RMII MAC interface
- Full Duplex
- 1Gbit (SGMII)
- 100Mbit (SGMII / RMII)
- No support for Ethernet fallback mode

USB over HDBaseT 2.0 / 3.0

USB over HDBaseT is compliant with the USB 2.0 specification and supports all types of USB transfers, including:

- Isochronous – e.g. Web cams, audio devices
- Bulk – e.g. Disk drives
- Interrupt – e.g. Keyboard, mouse
- Control (All devices)

USB over HDBaseT supports a maximum of 7 devices with dependent endpoints. In terms of bandwidth, the differences between HDBaseT 3.0 and 2.0 are:

- Spec 2.0: Up to 190Mb/s (for isochronous transfers)
- Spec 3.0 Up to 350Mb/s (for all transfers)

At A Glance: HDBaseT 3.0 Comparison Tables

The following table can help to further elucidate on some of HDBaseT Spec 3.0's features:

HDBaseT Link	HDBaseT Link Rate	HDMI Data Rate	HDR Formats Supported	ATEN Models (Example)
1.0/2.0 Uncompressed	8 Gbps	10 Gbps	4K UHD 24-30 fps 4:2:0/4:2:2	1.0: VE811/1812 2.0: CE820/920
1.0/2.0 with DSC Compressed	8 Gbps	11-18 Gbps	4K UHD 24-30 fps 4:4:4 4K UHD 48-60 fps 4:2:0/4:2:2	1.0: VE1830
3.0 Uncompressed	16 Gbps	18 Gbps	4K UHD 24-30 fps 4:4:4 4K UHD 48-60 fps 4:2:0/4:2:2	VE1843

Source: HDBaseT

How else does HDBaseT 3.0 differ from the previous two standards? The following table demonstrates some of the key differences:

Video – HDBaseT 1.0 / 2.0	Video – HDBaseT 3.0
<ul style="list-style-type: none"> HDMI 1.4 (HDMI 2.0 compatible) – maximum 340MHz pixel clock Uncompressed Full HD/3D and 4K/60/4:2:0 Support for EDID, HDCP, CEC pass-through Multi-streaming capability 	<ul style="list-style-type: none"> HDMI 2.0 – maximum 594MHz pixel clock Uncompressed 4K/60/4:4:4, HDR10/10+, DolbyVision Support for EDID, HDCP, CEC pass-through + HDCP Termination/Conversion (1.4<->2.X) Multi-streaming capability
Audio – HDBaseT 1.0 / 2.0 / 3.0	
<ul style="list-style-type: none"> Digital Audio is passed-through directly from the HDMI chipset All standard formats supported, e.g. Dolby Digital, DTS, Dolby TrueHD, DTS HD-Master Audio, Dolby Pro Logic IIz, 7.1 & 9.1 and more HDBaseT 2.0 / 3.0 support additional individual stereo audio channels 	

Source: HDBaseT

2. ATEN's HDBaseT 3.0 Solutions

True 4K HDMI / USB HDBaseT 3.0 Transceiver (VE1843)

To take AV distribution quality to the next level, ATEN has released the True 4K HDMI / USB HDBaseT 3.0 Transceiver ([VE1843](#)), ATEN's first video transceiver. It allows users to easily configure the unit to be a transmitter or receiver depending on the application, while enabling uncompressed [True 4K](#) HDMI transmission up to 100m/328ft with zero latency via just one Cat 6A cable.



The True 4K HDMI / USB HDBaseT 3.0 Transceiver (VE1843) features the HDBaseT 3.0 functionality and can be configured as a transmitter or receiver depending on the application.

VE1843 comes with HDMI audio embedding/de-embedding functions, enabling users to easily embed a separate audio source to video content for applications such as training and education, or de-embed an audio signal from an HDMI input source and output to an amplifier or speaker for enhanced sound quality.

Thanks to the above mentioned features, VE1843 is suited for small/mid-sized video [presentation](#) in areas such as conference rooms, banquet halls, exhibitions rooms, and public spaces such as atriums, where high-quality signal transmission up to 100m/328ft is needed.

The diagram on the following page illustrates how the VE1843 and HDBaseT 3.0 can be used in conjunction to cascade from Transmitter and Receiver and how the device can connect to the VK Control System, PCs, tablets, audio, and more:

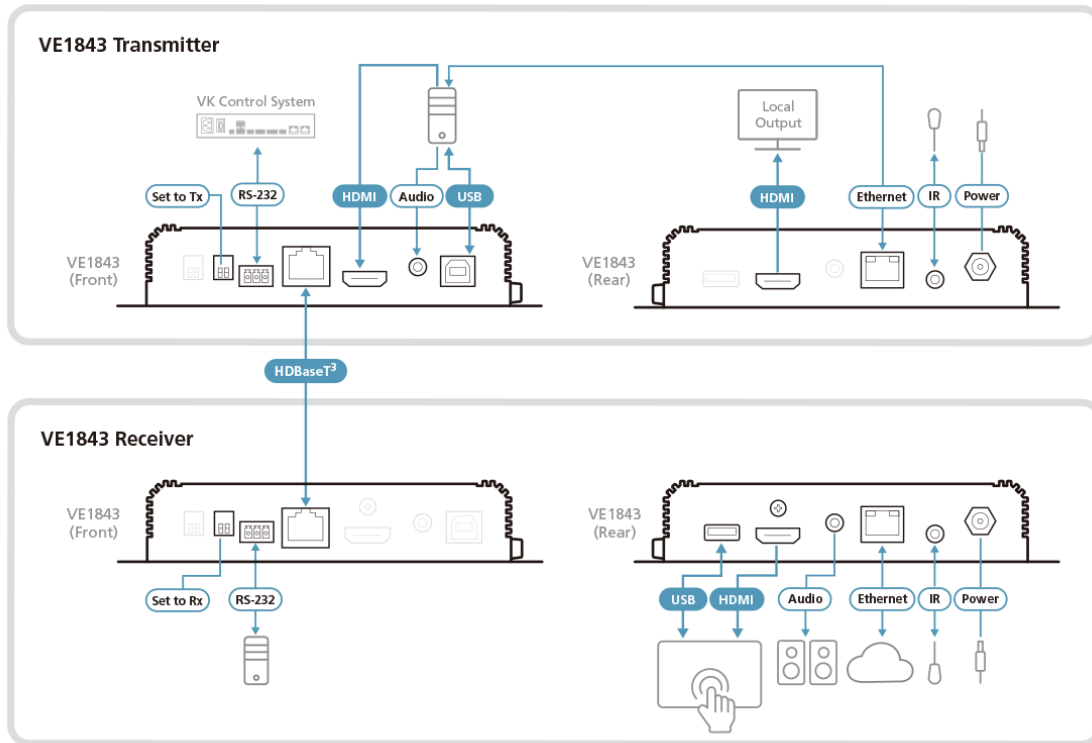

Real-World Application: VE1843 and HDBaseT 3.0

Let's take a look at a successful deployment of VE1843 in an educational application and how this transceiver, coupled with the power of HDBaseT 3.0, was able to deliver the solution the client needed.

Background: A university in Japan wanted to build a modern classroom where students in the space could easily and clearly focus on the teacher's lessons, no matter where the students were sitting in the large room.

Customer's Requirements:

1. Need to record the teaching and display it on TV monitors in real time for students who sit at the back of this large classroom.
2. Require true 4K video quality.
3. Remote control of the camera via IR or Ethernet.
4. USB connection for various equipment expansion.

The ATEN Solution: The ATEN VE1843 was chosen to fulfill the client’s needs. The VE1843 allowed for the transmission of IR, USB, Ethernet, and 4K HDMI over one cable up to 100m to deliver true 4K performance and integrate with Pro AV products in the educational space.

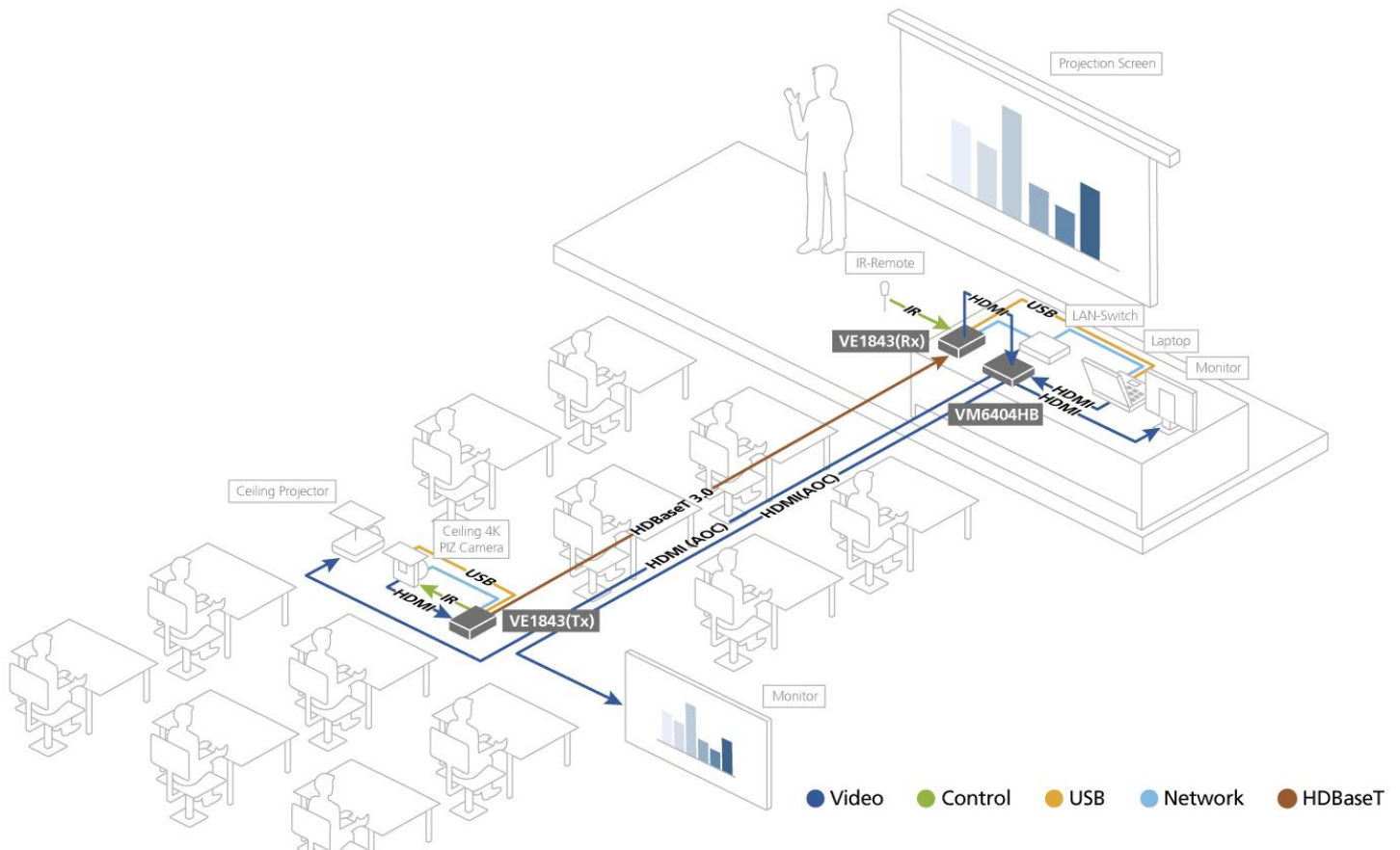

The ATEN VE1843 was used as both transmitter and receiver for transmission of multimedia content over HDBaseT 3.0 in the classroom so that students could see the instructor’s content no matter where they sat in the large room .

HDBaseT Cabling Solutions

For HDBaseT 3.0, we recommend using Cat 6A U/FTP as this cable type is required for HDBaseT 3.0 to enable 4K UHD at 60Hz 4:4:4 to 100m / 328ft. For HDBaseT 1.0 and 2.0, Cat 5e is the minimum requirement but ATEN 2L-2910 Cat6 is recommended to maximize the transmission distance for all resolutions up to 4K UHD at 60Hz 4:2:0 or 30Hz 4:4:4.

3. Conclusion

HDBaseT 3.0 represents an evolutionary move forward for Pro AV long-distance multimedia transmission and it stays ahead of the curve when it comes to installers' evolving requirements. While HDBaseT specs 1.0 and 2.0 still see widespread adoption, the step up to HDBaseT 3.0 heralds a new gold standard for uncompressed distribution, one that will rise to meet the challenges integrators face and the experience that end users desire.

As a contributor member of the HDBaseT Alliance, ATEN continues to help the Alliance to accelerate the integration of AV / IT technologies. In addition, ATEN utilizes the full capabilities of HDBaseT technology to develop a complete HDBaseT lineup – from the [VE1843](#) transceiver to a [wide range](#) of modular matrix switches (ex. VM1600A / 3200), extenders, and splitters (ex. VS1818T / 1814T) – to fulfill Pro AV demands in various scenarios.

To learn how ATEN HDBaseT solutions can help you deliver uncompressed multimedia, please feel free to contact our local representatives or read our HDBaseT [Brochure](#) and visit our HDBaseT [Solutions page](#).